

PRODUCT NO.
10108777-X0XXXX

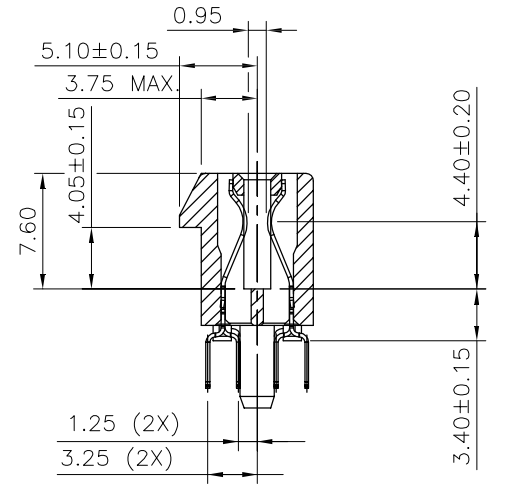

SECTION P-P

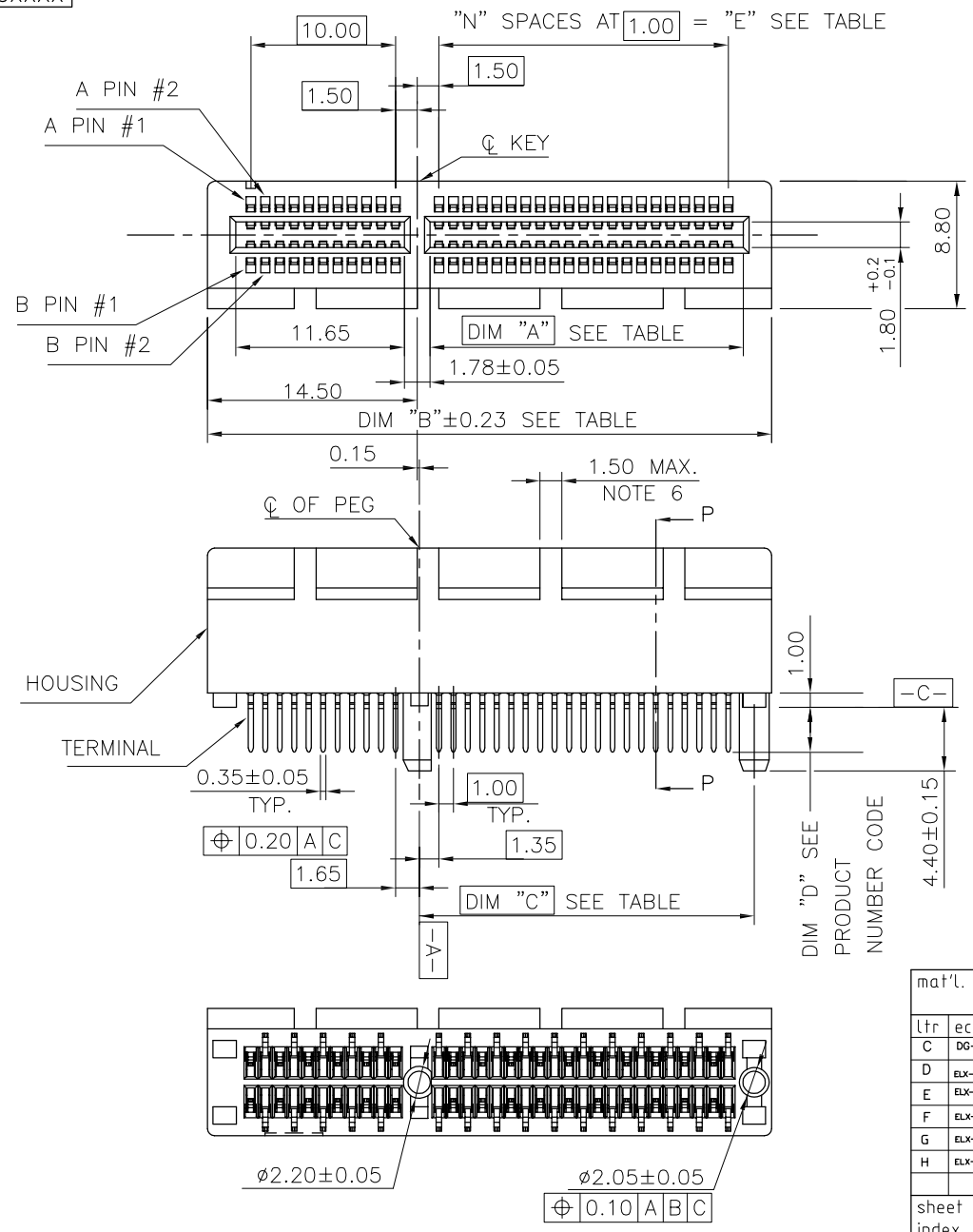
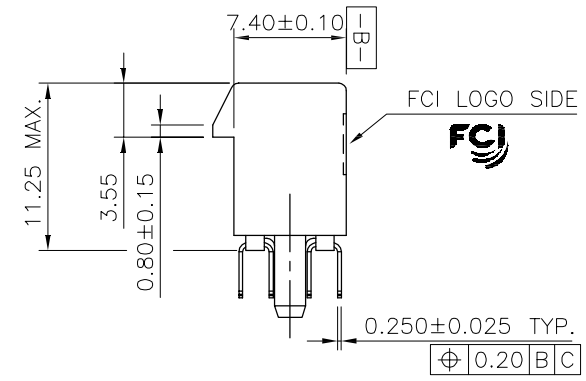

TWIN PLASTIC PEG TYPE

mat'l. code		surface		tolerance		projection		product family	
-		-		ASME_Y14.5		MM		PCI_EXPRESS	
lfr		ecn no		dr		date		title	
C	DG-011582	HT	5/10/12	tolerances unless otherwise specified				PCI_EXPRESS_CARD_EDGE_GEN3	
D	ELX-DG-013209	WL	07/24/12	angles	LineArt			TH_ASS'Y	
E	ELX-DG-2181-1	ST	05/27/15	±2'				sheet 1 of 7	
F	ELX-DG-24164	ZH	05/30/16	dr	ZHENHUA_LIU	2016-03-30		size	
G	ELX-DG-25671	ZH	12/18/16	enfr	ZHENHUA_LIU	2016-03-30		A4	
H	ELX-DG-27937	ZH	09/12/17	chr	STONE_LI	2016-03-30		10108777	
sheet		revision		H				type	
index		sheet						CUSTOMER Drawing	

PRODUCT NO.
10108777-X2XXXX



SINGLE PLASTIC PEG TYPE

mat'l. code		-		surface		- ✓		tolerance		ASME_Y14.5		projection		product family		PCI_EXPRESS	
lfr		ecn no		dr		date		tolerances unless otherwise specified		angles		MM		title		PCI_EXPRESS_CARD_EDGE_GEN3	
								±2'		LineGr		scale N/A		TH_ASS'Y		5	
				dr		ZHENHUA_LIU		2016-03-30		enfr		ZHENHUA_LIU		2016-03-30		dwg no	
				chr		STONE_LI		2016-03-30		appr		PM_ZHENG		2016-03-30		sheet 2 of 7	
sheet index		revision sheet		H										10108777		size A4	
														type		CUSTOMER Drawing	

PRODUCT NO.
10108777-X1XXXX

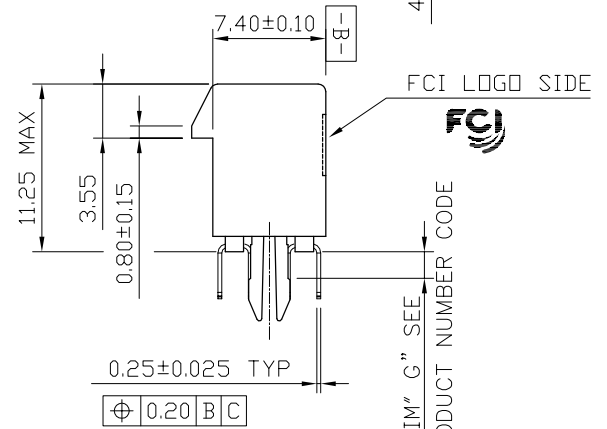
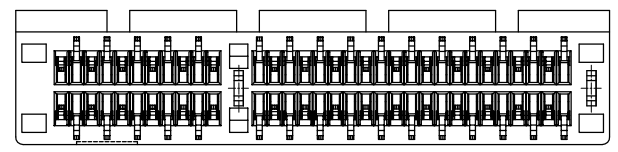
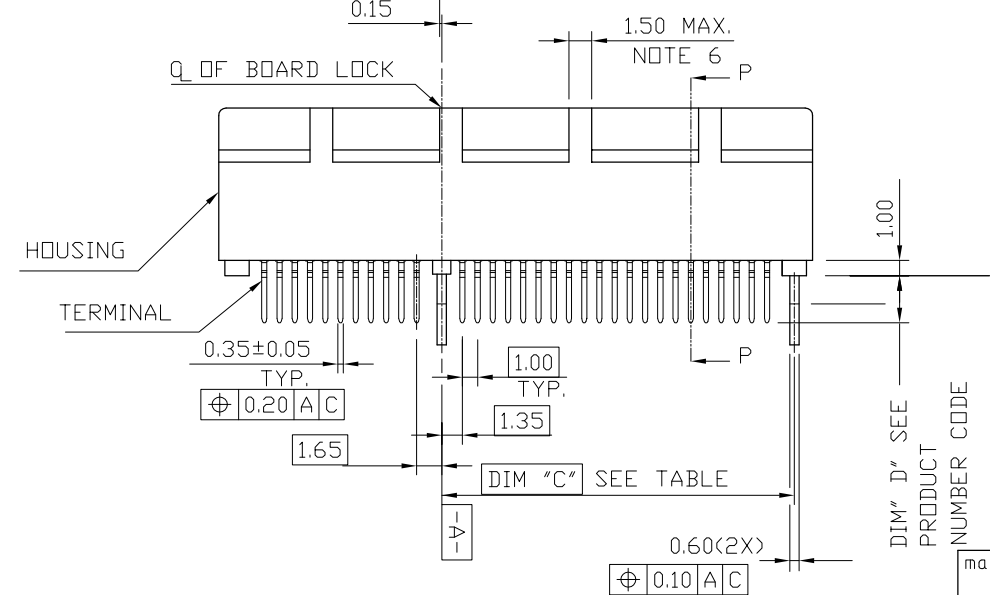

METAL BOARD LOCKS

mat'l. code	-	surface	-	tolerance	ASME_Y14.5	projection	MM	product family	PCI_EXPRESS
lfr	ecn no	dr	date	tolerances unless otherwise specified		MM		title	
				angles	.0±0.30			PCI_EXPRESS_CARD_EDGE_GEN3	
				±2'	.00±0.20			TH_ASS'Y	
					.000±0.10	scale N/A		dwg no	
				dr	ZHENHUA_LIU	2016-03-30	Amphenol FCI	sheet 3 of 7	
				enfr	ZHENHUA_LIU	2016-03-30		size	
				chr	STONE_LI	2016-03-30		10108777	
				appd	PM_ZHENG	2016-03-30		A4	
sheet index	revision sheet	H						type	
								CUSTOMER Drawing	

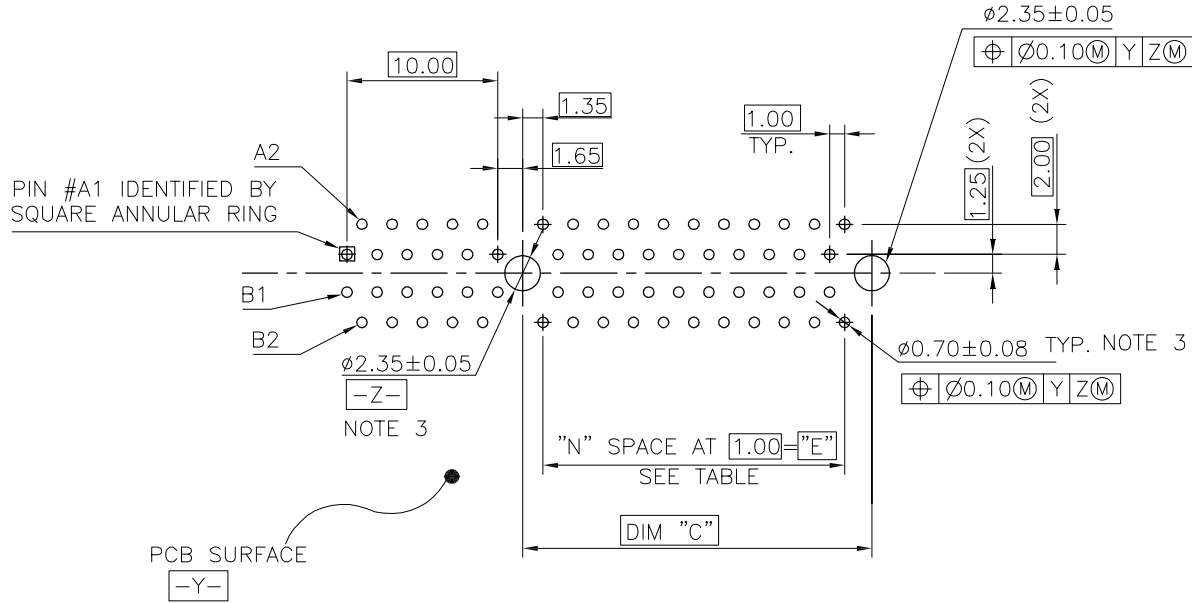

← I/O PANEL DIRECTION

RECOMMENDED FOOTPRINT

mat'l. code		-		surface		- ✓		tolerance		ASME_Y14.5		projection		product family		PCI_EXPRESS	
lfr	ecn no	dr	date	tolerances unless otherwise specified								title		PCI_EXPRESS_CARD_EDGE_GEN3			
				angles	linear	.02 ± 0.20		MM		scale N/A		TH_ASS'Y		5			
				±2'	linear	.00 ± 0.13						dwg no		sheet 4 of 7 size			
					linear	.000 ± 0.05				Amphenol FCI		10108777		A4			
				dr	ZHENHUA_LIU	2016-03-30						type		CUSTOMER Drawing			
				enfr	ZHENHUA_LIU	2016-03-30											
				chr	STONE_LI	2016-03-30											
				appd	PM_ZHENG	2016-03-30											
sheet index	revision sheet	H															



SCALE 2:1

← I/O PANEL DIRECTION
PRIMARY (COMPONENT) SIDE



I/O PANEL DIRECTION →
SECONDARY (SOLDER) SIDE

PIN "F" SEE TABLE 2.40±0.10 NOTE 4

PIN "F" SEE TABLE 2.40±0.10 NOTE 4

#	POS REF.	N	DIM "G"	"F"
36		6	8.15	B17
64		20	22.15	B31
98		37	39.15	B48
164		70	72.15	B81

ADD-IN CARD EDGE-FINGER DIMENSIONS

mat'l. code		surface		tolerance		projection		product family	
-		-		ASME_Y14.5				PCI_EXPRESS	
lfr		ecn no		dr		date		tolerances unless otherwise specified	
								title	
								MM	
								PCI_EXPRESS_CARD_EDGE_GEN3	
								TH_ASS'Y	
								scale N/A	
								dwg no	
								sheet 5 of 7	
								size	
								A4	
								type	
								CUSTOMER Drawing	
sheet index		revision sheet		H					

NOTES:

1.MATERIAL:

HOUSING: HIGH TEMPERATURE NYLON, GLASS FILLED UL94V-0 RATED.
TERMINAL: COPPER ALLOY.

PLATING: 50u" NICKEL UNDERPLATE ALL OVER
CONTACT AREA PLATING - SEE PRODUCT NUMBER CODE
SOLDER TAIL: TIN OR TIN /LEAD(90/10)- SEE PRODUCT NUMBER CODE 100u" MIN. OVER 50u" NICKEL.

METAL BOARD LOCKS: COPPER ALLOY.
FINISH: 100u" TIN OR TIN/LEAD(90/10) OVER 50u" NICKEL
UNDERPLATE SEE PRODUCT NUMBER CODE.

2.PRODUCT SPECIFICATION: GS-12-233.

③THE HORIZONTAL AXIS FOR THE HOLE PATTERN IS ESTABLISHED BY

A LINE THROUGH THE CENTER OF THE TWO Ø2.35 HOLES.
THE VERTICAL AXIS IS 90° TO THE HORIZONTAL AXIS, THROUGH THE CENTER OF DATUM Z.

④NO TIE BAR PERMITTED FROM CARD EDGE TO LEADING EDGE OF PAD FOR PINS A1 AND PIN NUMBERS "F".

⑤CHAMFER EDGES MUST BE FREE OF CUTTING BURRS.

⑥FREQUENCY & LOCATION AT SUPPLIER DISCRETION. RIDGE MAY BE CONTINUOUS WITH NO BREAKS.

7.RoHS COMPATIBLE PRODUCT SPECIFICATIONS:

a - PLATING:

- "LF" MEANS THE PRODUCT IS LEAD-FREE, 2um MINIMUM MATTE TIN OVER 1.27um MINIMUM NICKEL UNDERPLATE.

b - MANUFACTURING PROCESS COMPATIBILITY:

- THE HOUSING WILL WITHSTAND EXPOSURE TO 260°C±5°C TEMPERATURE FOR 10 SECONDS IN RE-FLOW APPLICATION, SEE NOTE 8 FOR APPLICATION.

PRODUCT NUMBER CODE

10108777 -X X X X X X □ □

HOUSING COLOR OPTIONS

- 0-NATURAL
- 1-BLACK

PEGS OPTIONS

- 0-PLASTIC PEGS, DIM
- 1-METAL BOARD LOCKS
- 2-SINGLE PLASTIC PEGS

TERMINAL PLATING OPTIONS

- 0-50u" Ni UNDERPLATE
30u" Au CONTACT AREA
100u" TIN TAIL AREA ----- COMPATIBLE RoHS
- 1-50u" Ni UNDERPLATE
15u" Au CONTACT AREA
100u" TIN TAIL AREA ----- COMPATIBLE RoHS
- 2-50u" Ni UNDERPLATE
GOLD FLASH CONTACT AREA
100u" TIN TAIL AREA ----- COMPATIBLE RoHS
- 3-50u" Ni UNDERPLATE
30u" Au CONTACT AREA
100u" TIN/LEAD TAIL AREA ---INCOMPLIANT RoHS
- 4-50u" Ni UNDERPLATE
15u" Au CONTACT AREA
100u" TIN/LEAD TAIL AREA ---INCOMPLIANT RoHS
- 5-50u" Ni UNDERPLATE
GOLD FLASH CONTACT AREA
100u" TIN/LEAD TAIL AREA ---INCOMPLIANT RoHS

LEAD FREE OPTION

LEAVE BLANK FOR TERMINAL PLATING 3.4.5
"LF" FOR TERMINAL PLATING OPTION 0,1,2

POS OPTIONS

- 0-36
- 1-64
- 2-98
- 3-164

TAIL LENGTH OPTIONS

	DIM "D"	PCB THICKNESS	DIM "G"
0	2.30 ^{+0.25} / _{-0.13}	1.56±0.10	1.70±0.15
1	3.10 ^{+0.25} / _{-0.13}	2.36±0.10	2.50±0.15
2	2.54±0.25	1.56±0.10	1.70±0.15
3	1.90±0.25	1.56±0.10	1.70±0.15
4	3.10 ^{+0.25} / _{-0.13}	2.0±0.10	1.70±0.15

CONNECTOR	# POS REF.	N	DIM "A"	DIM "B"	DIM "C"	"E"
1 PORT	36	6	7.65	25.00	9.15	6.00
4 PORT	64	20	21.65	39.00	23.15	20.00
8 PORT	98	37	38.65	56.00	40.15	37.00
16 PORT	164	70	71.65	89.00	73.15	70.00

8.AN ADEQUATE PROCEDURE SET FORTH IN THE FOLLOWING ENSURE THAT THE PRODUCT RELIABILITY CAN BE ACHIEVED DURING AND AFTER PCB ASSEMBLY OPERATION.

8.1IF PARTIAL LOT ARE USED, THE REMAINING CONNECTORS MUST BE RESEALED AND PLACED IN SAFE STORAGE WITHIN SIX HOURS OF BAG OPENING.

8.2THE SAFE STORAGE CONDITION IS RECOMMENDED AT 25°C, 40%RH.

8.3NOT FOLLOWING THE PROCEDURE MAY CAUSE BLISTER DAMAGE DURING RE-FLOW PROCESS.

8.4IF BAKING IS REQUIRED, CONNECTOR SHALL BE BAKED FOR 4 HOURS AT 125°C.

8.5REFERENCE SPECIFICATION: IPC/JEDEC J-STD-033A.

PACKAGING OPTIONS

E-HARD TRAY WITH MYLAR FOR VACUUM PACKAGING (FOR 164P ONLY)

T-SOFT TRAY PACKAGING

C-SOFT TRAY PACKAGING WITH 10MM CAP

M-SOFT TRAY PACKAGING & MYLAR TAPE. SEE FIGURE 1

Y-HARD TRAY PACKAGING (FOR 36P,98P AND 164P ONLY)

Z-HARD TRAY PACKAGING WITH MYLAR (FOR 36P,98P AND 164P ONLY)

H-SMALLER HARD TRAY PACKAGING WITH 30MM CAP (323X136X17.7 FOR 164P ONLY)

△ Q-SMALLER HARD TRAY PACKAGING (323X136X17.7 FOR 164P ONLY)

R-TAPE & REEL PACKAGING WITHOUT MYLAR

(FOR 34, 64, 98P ONLY)

W-TAPE & REEL PACKAGING WITHOUT MYLAR

(FOR 98P ONLY), WITH 18.0MM CAVITY WIDTH

A-TAPE & REEL PACKAGING WITH MYLAR

(FOR 36, 64, 98P ONLY)

mat'l. code		surface		tolerance		projection		product family	
-		-		ASME_Y14.5				PCI_EXPRESS	
lfr		ecn no		dr		date		title	
								PCI_EXPRESS_CARD_EDGE_GEN3	
								TH_ASS'Y	
								sheet 6 of 7	
								size	
								A4	
								type	
								CUSTOMER Drawing	
sheet index		revision		H					



POSTION OF MYLAR



POSTION OF CAP (10×10)



POSTION OF 30MM CAP(30X12)

mat'l. code		-		surface	-	tolerance	ASME_Y14.5	projection	product family	PCI_EXPRESS	
lfr	ecn no	dr	date	tolerances unless otherwise specified				MM	title		
				angles	±2'	linear	±.02±0.30		PCI_EXPRESS_CARD_EDGE_GEN3 TH_ASS'Y		
							.00±0.20	scale N/A	dwg no		
							.000±0.10		sheet 7 of 7 size		
				dr	ZHENHUA_LIU	2016-03-30		Amphenol FCI	10108777		
				enfr	ZHENHUA_LIU	2016-03-30			A4		
				chr	STONE_LI	2016-03-30			type		
				appd	PM_ZHENG	2016-03-30			CUSTOMER Drawing		
sheet index	revision sheet	H									

Данный компонент на территории Российской Федерации

Вы можете приобрести в компании MosChip.

Для оперативного оформления запроса Вам необходимо перейти по данной ссылке:

<http://moschip.ru/get-element>

Вы можете разместить у нас заказ для любого Вашего проекта, будь то серийное производство или разработка единичного прибора.

В нашем ассортименте представлены ведущие мировые производители активных и пассивных электронных компонентов.

Нашей специализацией является поставка электронной компонентной базы двойного назначения, продукции таких производителей как XILINX, Intel (ex.ALTERA), Vicor, Microchip, Texas Instruments, Analog Devices, Mini-Circuits, Amphenol, Glenair.

Сотрудничество с глобальными дистрибьюторами электронных компонентов, предоставляет возможность заказывать и получать с международных складов практически любой перечень компонентов в оптимальные для Вас сроки.

На всех этапах разработки и производства наши партнеры могут получить квалифицированную поддержку опытных инженеров.

Система менеджмента качества компании отвечает требованиям в соответствии с ГОСТ Р ИСО 9001, ГОСТ РВ 0015-002 и ЭС РД 009

Офис по работе с юридическими лицами:

105318, г.Москва, ул.Щербаковская д.3, офис 1107, 1118, ДЦ «Щербаковский»

Телефон: +7 495 668-12-70 (многоканальный)

Факс: +7 495 668-12-70 (доб.304)

E-mail: info@moschip.ru

Skype отдела продаж:

moschip.ru

moschip.ru_4

moschip.ru_6

moschip.ru_9