

PRODUCT NO.
10108777-X2XXXX

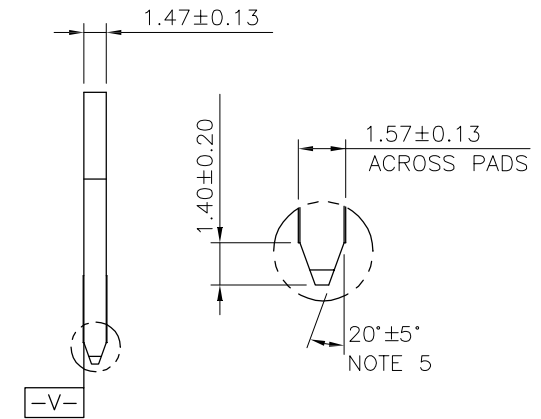

SINGLE PLASTIC PEG TYPE

mat'l. code		surface		tolerance		projection		product family	
-		-		ASME_Y14.5				PCI_EXPRESS	
lfr		ecn no		date				title	
						MM		PCI_EXPRESS_CARD_EDGE_GEN3	
						scale N/A		TH_ASS'Y	
		dr		ZHENHUA_LIU		2016-03-30		dwg no	
		enfr		ZHENHUA_LIU		2016-03-30		sheet 2 of 7	
		chr		STONE_LI		2016-03-30		size	
		appd		PM_ZHENG		2016-03-30		A4	
sheet index		revision sheet		H				10108777	
								type	
								CUSTOMER Drawing	



SCALE 2:1

← I/O PANEL DIRECTION
PRIMARY (COMPONENT) SIDE

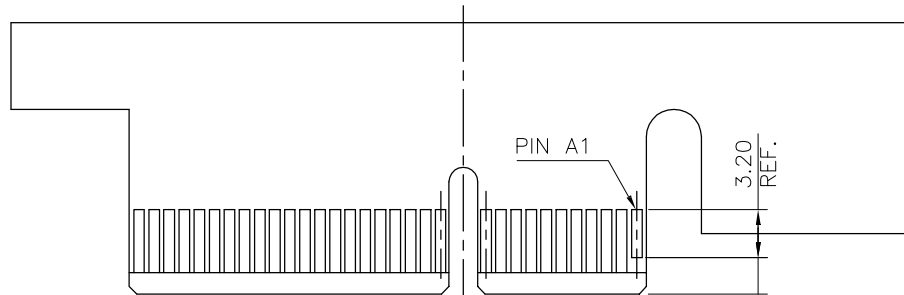

I/O PANEL DIRECTION →
SECONDARY (SOLDER) SIDE

PIN "F" SEE TABLE 2.40 ± 0.10 NOTE 4

PIN "F" SEE TABLE 2.40 ± 0.10 NOTE 4

#	POS REF.	N	DIM "G"	"F"
36		6	8.15	B17
64		20	22.15	B31
98		37	39.15	B48
164		70	72.15	B81

ADD-IN CARD EDGE-FINGER DIMENSIONS

mat'l. code		-		surface		- ✓		tolerance		ASME_Y14.5		projection		product family		PCI_EXPRESS	
lfr		ecn no		dr		date		tolerances unless otherwise specified		MM		title		PCI_EXPRESS_CARD_EDGE_GEN3		TH_ASS'Y	
								angles		.02 ± 0.20		scale N/A		dwg no		sheet 5 of 7 size	
								±2'		.00 ± 0.13		Amphenol FCI		10108777		A4	
				dr		ZHENHUA_LIU		2016-03-30						type		CUSTOMER Drawing	
				enfr		ZHENHUA_LIU		2016-03-30									
				chr		STONE_LI		2016-03-30									
				appd		PM_ZHENG		2016-03-30									
sheet index		revision sheet		H													

NOTES:

1.MATERIAL:

HOUSING: HIGH TEMPERATURE NYLON, GLASS FILLED UL94V-0 RATED.
TERMINAL: COPPER ALLOY.

PLATING: 50u" NICKEL UNDERPLATE ALL OVER
CONTACT AREA PLATING - SEE PRODUCT NUMBER CODE
SOLDER TAIL: TIN OR TIN /LEAD(90/10)- SEE PRODUCT
NUMBER CODE 100u" MIN. OVER 50u" NICKEL.

METAL BOARD LOCKS: COPPER ALLOY.
FINISH: 100u" TIN OR TIN/LEAD(90/10) OVER 50u" NICKEL
UNDERPLATE SEE PRODUCT NUMBER CODE.

2.PRODUCT SPECIFICATION: GS-12-233.

③THE HORIZONTAL AXIS FOR THE HOLE PATTERN IS ESTABLISHED BY

A LINE THROUGH THE CENTER OF THE TWO Ø2.35 HOLES.
THE VERTICAL AXIS IS 90° TO THE HORIZONTAL AXIS, THROUGH THE CENTER
OF DATUM Z.

④NO TIE BAR PERMITTED FROM CARD EDGE TO LEADING EDGE OF PAD FOR PINS A1 AND PIN NUMBERS "F".

⑤CHAMFER EDGES MUST BE FREE OF CUTTING BURRS.

⑥FREQUENCY & LOCATION AT SUPPLIER DISCRETION. RIDGE MAY BE CONTINUOUS WITH NO BREAKS.

7.RoHS COMPATIBLE PRODUCT SPECIFICATIONS:

a - PLATING:

- "LF" MEANS THE PRODUCT IS LEAD-FREE, 2um MINIMUM MATTE TIN OVER 1.27um
MINIMUM NICKEL UNDERPLATE.

b - MANUFACTURING PROCESS COMPATIBILITY:

- THE HOUSING WILL WITHSTAND EXPOSURE TO 260°C±5°C TEMPERATURE FOR
10 SECONDS IN RE-FLOW APPLICATION, SEE NOTE 8 FOR APPLICATION.

PRODUCT NUMBER CODE

10108777 -X X X X X X

HOUSING COLOR OPTIONS

- 0-NATURAL
- 1-BLACK

PEGS OPTIONS

- 0-PLASTIC PEGS, DIM
- 1-METAL BOARD LOCKS
- 2-SINGLE PLASTIC PEGS

TERMINAL PLATING OPTIONS

- 0-50u" Ni UNDERPLATE
30u" Au CONTACT AREA
100u" TIN TAIL AREA ----- COMPATIBLE RoHS
- 1-50u" Ni UNDERPLATE
15u" Au CONTACT AREA
100u" TIN TAIL AREA ----- COMPATIBLE RoHS
- 2-50u" Ni UNDERPLATE
GOLD FLASH CONTACT AREA
100u" TIN TAIL AREA ----- COMPATIBLE RoHS
- 3-50u" Ni UNDERPLATE
30u" Au CONTACT AREA
100u" TIN/LEAD TAIL AREA ---INCOMPLIANT RoHS
- 4-50u" Ni UNDERPLATE
15u" Au CONTACT AREA
100u" TIN/LEAD TAIL AREA ---INCOMPLIANT RoHS
- 5-50u" Ni UNDERPLATE
GOLD FLASH CONTACT AREA
100u" TIN/LEAD TAIL AREA ---INCOMPLIANT RoHS

LEAD FREE OPTION

LEAVE BLANK FOR TERMINAL PLATING 3.4.5
"LF" FOR TERMINAL PLATING OPTION 0,1,2

POS OPTIONS

- 0-36
- 1-64
- 2-98
- 3-164

TAIL LENGTH OPTIONS

	DIM "D"	PCB THICKNESS	DIM "G"
0	2.30 ^{+0.25} / _{-0.13}	1.56±0.10	1.70±0.15
1	3.10 ^{+0.25} / _{-0.13}	2.36±0.10	2.50±0.15
2	2.54±0.25	1.56±0.10	1.70±0.15
3	1.90±0.25	1.56±0.10	1.70±0.15
4	3.10 ^{+0.25} / _{-0.13}	2.0±0.10	1.70±0.15

CONNECTOR	# POS REF.	N	DIM "A"	DIM "B"	DIM "C"	"E"
1 PORT	36	6	7.65	25.00	9.15	6.00
4 PORT	64	20	21.65	39.00	23.15	20.00
8 PORT	98	37	38.65	56.00	40.15	37.00
16 PORT	164	70	71.65	89.00	73.15	70.00

- 8.AN ADEQUATE PROCEDURE SET FORTH IN THE FOLLOWING ENSURE THAT THE PRODUCT
RELIABILITY CAN BE ACHIEVED DURING AND AFTER PCB ASSEMBLY OPERATION.
- 8.1IF PARTIAL LOT ARE USED, THE REMAINING CONNECTORS MUST BE RESEALED AND
PLACED IN SAFE STORAGE WITHIN SIX HOURS OF BAG OPENING.
- 8.2THE SAFE STORAGE CONDITION IS RECOMMENDED AT 25°C, 40%RH.
- 8.3NOT FOLLOWING THE PROCEDURE MAY CAUSE BLISTER DAMAGE DURING RE-FLOW PROCESS.
- 8.4IF BAKING IS REQUIRED, CONNECTOR SHALL BE BAKED FOR 4 HOURS AT 125°C.
- 8.5REFERENCE SPECIFICATION: IPC/JEDEC J-STD-033A.

PACKAGING OPTIONS

- E-HARD TRAY WITH MYLAR FOR VACUUM PACKAGING (FOR 164P ONLY)
- T-SOFT TRAY PACKAGING
- C-SOFT TRAY PACKAGING WITH 10MM CAP
- M-SOFT TRAY PACKAGING & MYLAR TAPE. SEE FIGURE 1
- Y-HARD TRAY PACKAGING (FOR 36P,98P AND 164P ONLY)
- Z-HARD TRAY PACKAGING WITH MYLAR (FOR 36P,98P AND 164P ONLY)
- H-SMALLER HARD TRAY PACKAGING WITH 30MM CAP (323X136X17.7 FOR 164P ONLY)
- △ Q-SMALLER HARD TRAY PACKAGING (323X136X17.7 FOR 164P ONLY)
- R-TAPE & REEL PACKAGING WITHOUT MYLAR
(FOR 34, 64, 98P ONLY)
- W-TAPE & REEL PACKAGING WITHOUT MYLAR
(FOR 98P ONLY), WITH 18.0MM CAVITY WIDTH
- A-TAPE & REEL PACKAGING WITH MYLAR
(FOR 36, 64, 98P ONLY)

mat'l. code		surface		tolerance		projection		product family	
-		-		ASME_Y14.5				PCI_EXPRESS	
lfr		ecn no		dr		date		title	
								PCI_EXPRESS_CARD_EDGE_GEN3	
								TH_ASS'Y	
								dwg no	
								sheet 6 of 7	
								size	
								A4	
								type	
								CUSTOMER Drawing	
sheet		revision		H					
index		sheet							



POSTION OF MYLAR

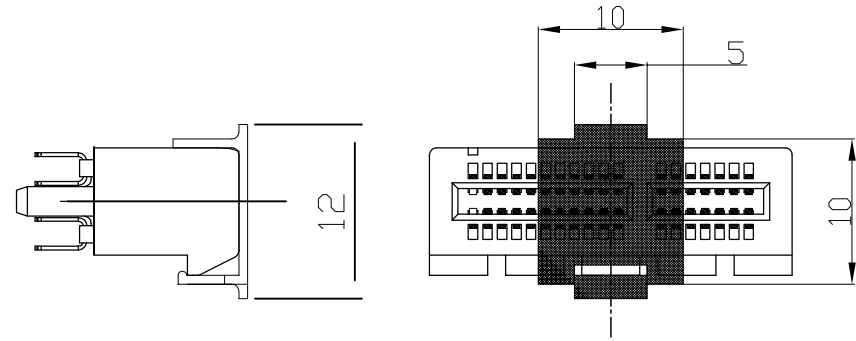

POSTION OF CAP (10×10)



POSTION OF 30MM CAP(30X12)

mat'l. code		surface		tolerance		projection		product family	
-		-		ASME_Y14.5				PCI_EXPRESS	
lfr		ecn no		dr		date		title	
								PCI_EXPRESS_CARD_EDGE_GEN3	
				angles				TH_ASS'Y	
				±2'				scale N/A	
		dr		ZHENHUA_LIU		2016-03-30		dwg no	
		enfr		ZHENHUA_LIU		2016-03-30		sheet 7 of 7	
		chr		STONE_LI		2016-03-30		size	
		appd		PM_ZHENG		2016-03-30		A4	
sheet		revision		H				type	
index		sheet						CUSTOMER Drawing	

Данный компонент на территории Российской Федерации

Вы можете приобрести в компании MosChip.

Для оперативного оформления запроса Вам необходимо перейти по данной ссылке:

<http://moschip.ru/get-element>

Вы можете разместить у нас заказ для любого Вашего проекта, будь то серийное производство или разработка единичного прибора.

В нашем ассортименте представлены ведущие мировые производители активных и пассивных электронных компонентов.

Нашей специализацией является поставка электронной компонентной базы двойного назначения, продукции таких производителей как XILINX, Intel (ex.ALTERA), Vicor, Microchip, Texas Instruments, Analog Devices, Mini-Circuits, Amphenol, Glenair.

Сотрудничество с глобальными дистрибьюторами электронных компонентов, предоставляет возможность заказывать и получать с международных складов практически любой перечень компонентов в оптимальные для Вас сроки.

На всех этапах разработки и производства наши партнеры могут получить квалифицированную поддержку опытных инженеров.

Система менеджмента качества компании отвечает требованиям в соответствии с ГОСТ Р ИСО 9001, ГОСТ РВ 0015-002 и ЭС РД 009

Офис по работе с юридическими лицами:

105318, г.Москва, ул.Щербаковская д.3, офис 1107, 1118, ДЦ «Щербаковский»

Телефон: +7 495 668-12-70 (многоканальный)

Факс: +7 495 668-12-70 (доб.304)

E-mail: info@moschip.ru

Skype отдела продаж:

moschip.ru

moschip.ru_4

moschip.ru_6

moschip.ru_9