

AIF - PFC Series

1600 Watts

Total Power: 1600 Watts
/120 - 370VDC
(Configurable)
Input Voltage: 85 - 264VAC
of Outputs: Single



Special Features

- Unity power factor
- High efficiency - up to 95%
- Universal input voltage and frequency range
- Up to 1600W output power
- Positive and Negative enable function
- Parallelable with accurate current sharing
- <10% harmonic distortion conforming to IEC1000-3-2 Compliance
- 100°C baseplate operating temperature
- DC Input option
- Power fail warning signal
- Enable output to control DC-DC Converter
- EEPROM data storage via I²C Interface
- External inrush current limited protection
- Power Density up to 290W/in³

Safety

UL 60950 Recognized
cUL 60950 Recognized
TUV EN60950 Licensed

Electrical Specifications

Input

Input range	85 - 264 Vac / 120 - 370 Vdc (configurable)
Input surge	290 Vac / 1s
Input Frequency	50/60 Hz
Efficiency	95% @ 230Vac, 1600 W (typical)
Total Harmonic Distortion	Less than 10%
Power Factor	0.99 typical (Po ± 500 W); 0.97 typical (Po ± 1000 W)

Output

Output Voltage	380V typical (Io = 4.2A / Vi > 180 Vac); 393V typical (Io = 0A) Note: Vin peak must always be lower than Vout
Current Share Accuracy	10% max
Overvoltage Protection	430 max
Power Limit for AC input	Vin = 85Vac, Pmax = 1000W; Vin = 230Vac, Pmax = 1600W
for DC input	Vin = 370Vdc, Pmax = 1600W

Control

Power Fail Warning	Direct drive output to opto-isolator
Power Fail Warning Adjust	195 to 355Vdc adjustable
LD Enable	Direct drive output to opto-isolator
PFC Enable	TTL compatible
Voltage Adjust	76% to 100% Vo
DC Input Enable	
Clock Input (external sync)	6Vp-p typical @ 1MHz ± 5%
Clock Output (int. clock)	6Vp-p typical @ 1MHz ± 5%
Temperature Monitor Output	10mV/°C
Current Monitor Output	0 to 1mA (1mA = 4.2A output)
I ² C Interface	

Notes

Nominal values apply with sense pins disconnected and other control pin unconnected.



Environmental Specifications

Operating temperature	-20°C to +100°C (baseplate temperature)
Startup temperature	-40°C to +100°C (baseplate temperature)
Storage temperature	-40°C to +120°C
Overtemperature protection	120°C max
MTBF	1million hours

Ordering Information

Model Number	Description	Notes
AIF04ZPFC-01L	1600W Low Profile PC Module	For parallel operation the total input current must be <16Arms.
AIF04ZPFC-02L	1600W Low Profile PC Module	Designed for parallel operation where the total input current >16Arms, requires external rail rectifiers.
AIF04ZPFC-01NL		Negative Enable
AIF04ZPFC-01NL		Negative Enable

1. Fon Non-thread hole, add suffix "-NT".

Mechanical Drawing

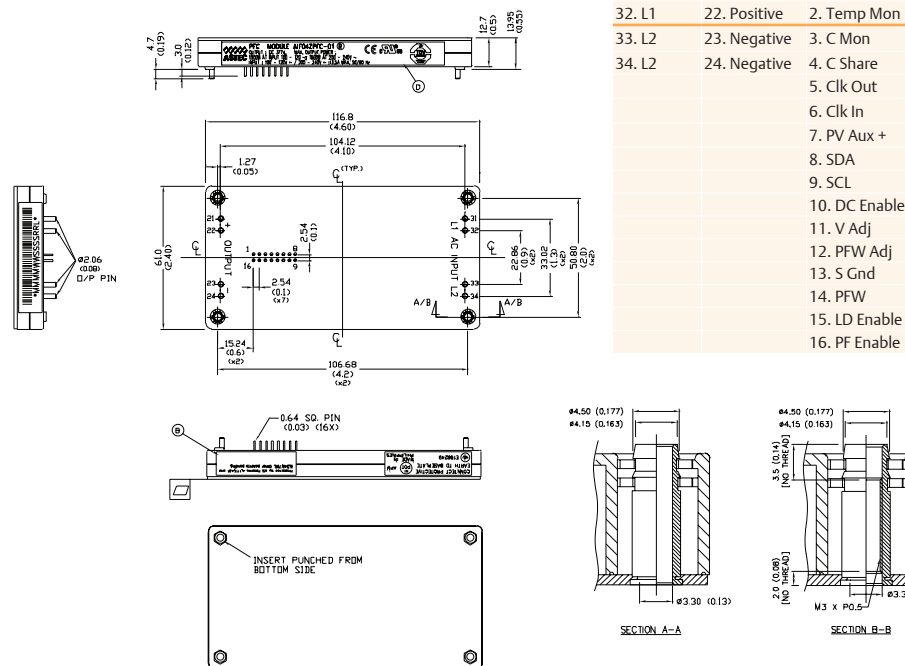

Pin Assignments

Input (AC)	Output (DC)	Control Pins
31. L1	21. Positive	1. PV Aux -
32. L1	22. Positive	2. Temp Mon
33. L2	23. Negative	3. C Mon
34. L2	24. Negative	4. C Share
		5. Clk Out
		6. Clk In
		7. PV Aux +
		8. SDA
		9. SCL
		10. DC Enable
		11. V Adj
		12. PFW Adj
		13. S Gnd
		14. PFW
		15. LD Enable
		16. PF Enable

Americas

5810 Van Allen Way
Carlsbad, CA 92008
USA
Telephone: +1 760 930 4600
Facsimile: +1 760 930 0698

Europe (UK)

Waterfront Business Park
Merry Hill, Dudley
West Midlands, DY5 1LX
United Kingdom
Telephone: +44 (0) 1384 842 211
Facsimile: +44 (0) 1384 843 355

Asia (HK)

14/F, Lu Plaza
2 Wing Yip Street
Kwun Tong, Kowloon
Hong Kong
Telephone: +852 2176 3333
Facsimile: +852 2176 3888

For global contact, visit:

www.Emerson.com/EmbeddedPower
techsupport.embeddedpower@emerson.com

While every precaution has been taken to ensure accuracy and completeness in this literature, Emerson Network Power assumes no responsibility, and disclaims all liability for damages resulting from use of this information or for any errors or omissions.

Emerson Network Power.

The global leader in enabling business-critical continuity.

- AC Power
- Connectivity
- DC Power
- Embedded Computing
- Embedded Power**
- Monitoring
- Outside Plant
- Power Switching & Controls
- Precision Cooling
- Racks & Integrated Cabinets
- Services
- Surge Protection

EmersonNetworkPower.com

Emerson Network Power and the Emerson Network Power logo are trademarks and service marks of Emerson Electric Co.
©2010 Emerson Electric Co.

Данный компонент на территории Российской Федерации

Вы можете приобрести в компании MosChip.

Для оперативного оформления запроса Вам необходимо перейти по данной ссылке:

<http://moschip.ru/get-element>

Вы можете разместить у нас заказ для любого Вашего проекта, будь то серийное производство или разработка единичного прибора.

В нашем ассортименте представлены ведущие мировые производители активных и пассивных электронных компонентов.

Нашей специализацией является поставка электронной компонентной базы двойного назначения, продукции таких производителей как XILINX, Intel (ex.ALTERA), Vicor, Microchip, Texas Instruments, Analog Devices, Mini-Circuits, Amphenol, Glenair.

Сотрудничество с глобальными дистрибьюторами электронных компонентов, предоставляет возможность заказывать и получать с международных складов практически любой перечень компонентов в оптимальные для Вас сроки.

На всех этапах разработки и производства наши партнеры могут получить квалифицированную поддержку опытных инженеров.

Система менеджмента качества компании отвечает требованиям в соответствии с ГОСТ Р ИСО 9001, ГОСТ РВ 0015-002 и ЭС РД 009

Офис по работе с юридическими лицами:

105318, г.Москва, ул.Щербаковская д.3, офис 1107, 1118, ДЦ «Щербаковский»

Телефон: +7 495 668-12-70 (многоканальный)

Факс: +7 495 668-12-70 (доб.304)

E-mail: info@moschip.ru

Skype отдела продаж:

moschip.ru

moschip.ru_4

moschip.ru_6

moschip.ru_9