

### FEATURES

- 10-Bit Resolution
- Two Monolithic Complete 10-Bit ADCs
- 40 MSPS Conversion Rate
- On-Chip Track-and-Hold
- On-Chip Voltage Reference
- Low 5 pF Input Capacitance
- TTL/CMOS Outputs
- Tri-State Output Buffers
- Single +3.0V Power Supply Operation
- Low Power Dissipation: 200mW-typ @ 2.7V
- Power Down Mode Less Than 5mW
- 75dB Crosstalk (fin=1.0MHz)
- -40°C to +85°C Operation Temperature Range

### APPLICATIONS

- Medical Imaging
- Instrumentation
- Data Acquisition Systems
- Digital Communications

### BENEFITS

- Reduction of Components
- Reduction of System Cost
- High Performance @ Low Power Dissipation
- Long Term Time and Temperature Stability

### GENERAL DESCRIPTION

The XRD64L43 is two 10-bit, monolithic, 40 MSPS ADCs. Manufactured using a standard CMOS process, the XRD64L43 offers low power, low cost and excellent performance. The on-chip track-and-hold amplifier (T/H) and voltage reference (VREF) eliminate the need for external active components, requiring only an external ADC conversion clock for the application. The XRD64L43 analog input can be driven with ease due to the high input impedance.

The design architecture uses 17 time-interleaved 10-bit SAR ADCs in each converter to achieve high conversion rate of 40 MSPS minimum. In order to insure and maintain accurate 10-bit operation with respect to time and temperature, XRD64L43 incorporates an auto-calibration circuit which continuously adjusts and matches the offset and linearity of each ADC. This auto-calibration circuit is transparent to the

user after the initial 4.2ms calibration (168,000 initial clock cycles).

The power dissipation is only 200mW at 40 MSPS with +2.7V power supply.

The digital output data is straight binary format, and the tri-state disable function is provided for common bus interface.

The XRD64L43 internal reference provides cost savings and simplifies the design/development. The output voltage of the internal reference is set by two external resistors. The internal reference can be disabled if an external reference is used for a power savings of 50mW.

### ORDERING INFORMATION

Part Number	Package Type	Temperature Range
XRD64L43AIV	64-Lead LQFP	-40°C to +85°C

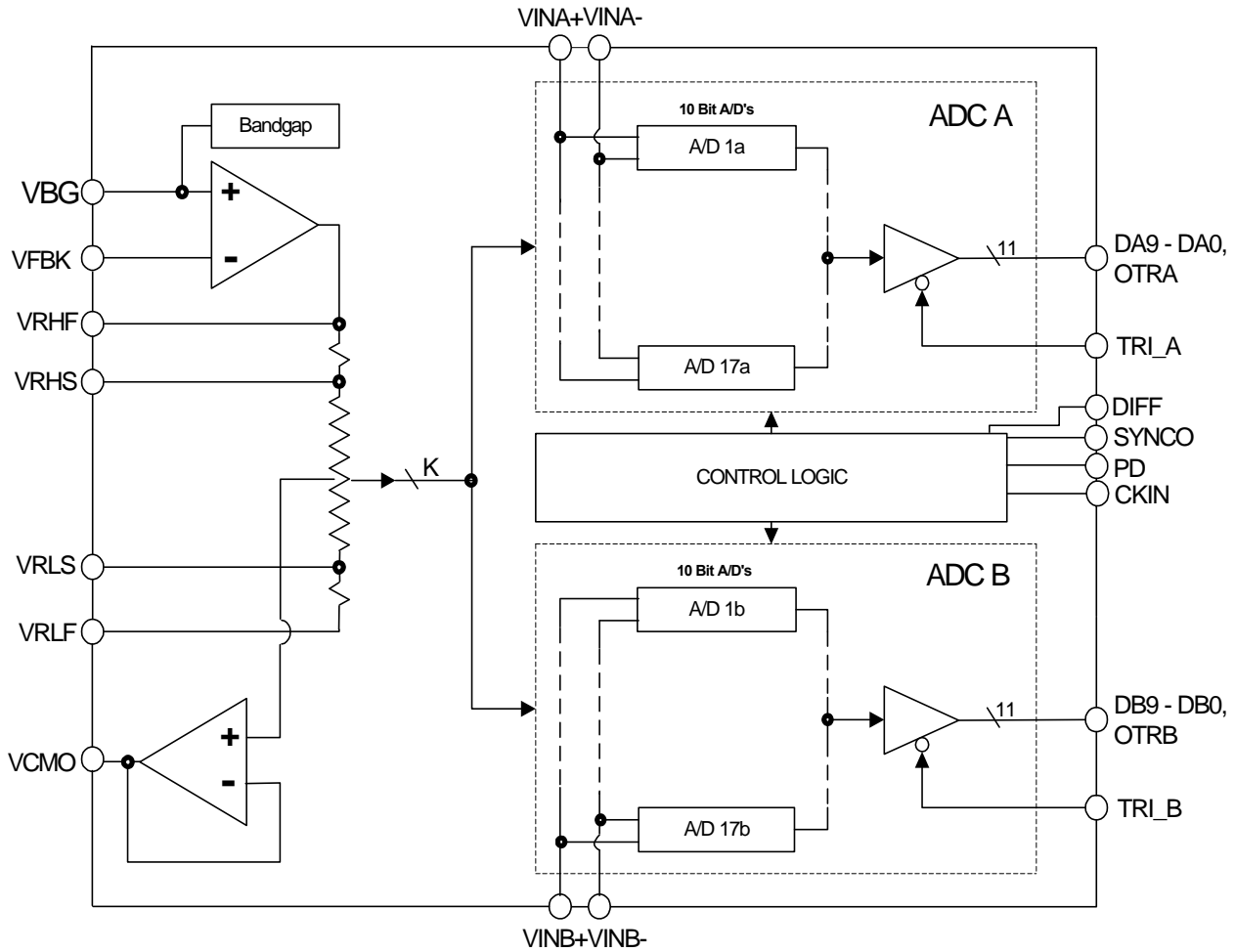
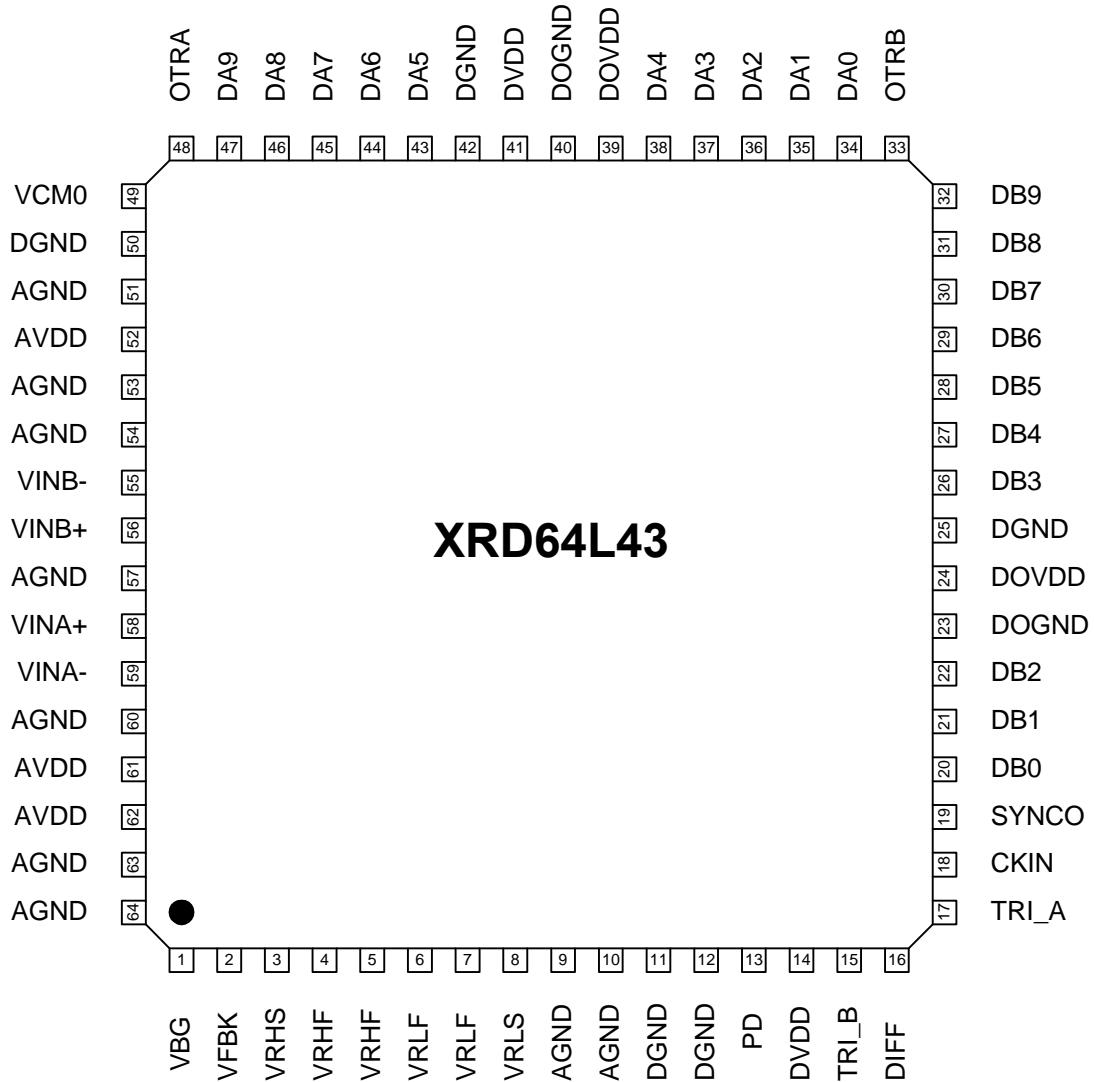


Figure 1. XRD64L43 Simplified Block Diagram



## PIN DESCRIPTION

Pin #	Symbol	Description
1	VBG	Bandgap Voltage Output
2	VFBK	Analog Reference Feedback
3	VRHS	Top Voltage Reference Sense
4	VRHF	Top Voltage Reference Force
5	VRHF	Top Voltage Reference Force
6	VRLF	Bottom Voltage Reference Force
7	VRLF	Bottom Voltage Reference Force
8	VRLS	Bottom Voltage Reference Sense
9	AGND	Analog Ground
10	AGND	Analog Ground
11	DGND	Digital Ground
12	DGND	Digital Ground
13	PD	Power Down, Active High
14	DVDD	Digital Supply Voltage
15	TRI_B	Tri-state for the B Channel Outputs, Active High
16	DIFF	Hi=Differential Mode, Lo=Single-Ended Mode
17	TRI_A	Tri-state for the A Channel Outputs, Active High
18	CKIN	Clock Input
19	SYNCO	Data Valid Output (Rising Edge)
20	DB0	Digital Output Bit 0 (LSB) ADC B
21	DB1	Digital Output Bit 1 ADC B
22	DB2	Digital Output Bit 2 ADC B
23	DOGND	Digital Output Ground
24	DOVDD	Digital Output Supply Voltage
25	DGND	Digital Ground
26	DB3	Digital Output Bit 3 ADC B
27	DB4	Digital Output Bit 4 ADC B
28	DB5	Digital Output Bit 5 ADC B
29	DB6	Digital Output Bit 6 ADC B
30	DB7	Digital Output Bit 7 ADC B
31	DB8	Digital Output Bit 8 ADC B
32	DB9	Digital Output Bit 9 (MSB) ADC B
33	OTRB	Over Range Digital Output Bit ADC B
34	DA0	Digital Output Bit 0 (LSB) ADC A
35	DA1	Digital Output Bit 1 ADC A
36	DA2	Digital Output Bit 2 ADC A
37	DA3	Digital Output Bit 3 ADC A
38	DA4	Digital Output Bit 4 ADC A
39	DOVDD	Digital Output Supply Voltage
40	DOGND	Digital Output Ground
41	DVDD	Digital Supply Voltage

**PIN DESCRIPTION (CONT'D)**

<b>Pin #</b>	<b>Symbol</b>	<b>Description</b>
42	DGND	Digital Ground
43	DA5	Digital Output Bit 5 ADC A
44	DA6	Digital Output Bit 6 ADC A
45	DA7	Digital Output Bit 7 ADC A
46	DA8	Digital Output Bit 8 ADC A
47	DA9	Digital Output Bit 9 ADC A
48	OTRA	Over Range Digital Output Bit ADC A
49	VCMO	Differential Common Mode Voltage Output
50	DGND	Digital Ground
51	AGND	Analog Ground
52	AVDD	Analog Supply Voltage
53	AGND	Analog Ground
54	AGND	Analog Ground
55	VINB-	Analog Input B(-)
56	VINB+	Analog Input B(+)
57	AGND	Analog Ground
58	VINA+	Analog Input A(+)
59	VINA-	Analog Input A(-)
60	AGND	Analog Ground
61	AVDD	Analog Supply Voltage
62	AVDD	Analog Supply Voltage
63	AGND	Analog Ground
64	AGND	Analog Ground

## ELECTRICAL CHARACTERISTICS TABLE (CONT'D)

## Test Conditions (Unless Otherwise Specified)

$T_A = 25^\circ\text{C}$ ,  $AV_{DD} = DV_{DD} = +3.0\text{V}$ ,  $V_{IN} = \text{GND to } +2.5\text{V}$ ,  $V_{RLF} = \text{GND}$ ,  $V_{RHF} = +2.5\text{V}$  and  $F_s = 40 \text{ MSPS}$ , 50% Duty Cycle, Differential Input Mode

Symbol	Parameter	Min.	Typ.	Max.	Unit	Conditions	
<b>DC ACCURACY</b>							
DNL	Differential Non-Linearity	-0.75	+/-0.25	0.75	LSB		
INL	Integral Non-Linearity		+/-0.5		LSB		
MON	Monotonicity	No Missing Codes					Guaranteed by Test
FSE	Full Scale Error		$\pm 10$		mV	Note 1	
ZSE	Zero Scale Error		5		mV	Single Ended Mode	
<b>ANALOG INPUT</b>							
INVR	Input Voltage Range	1		VRHS - VRLS	V	VRLF Grounded	
INRES	Input Resistance		20		KOhms		
INCAP	Input Capacitance		5		pF		
INBW	Input Bandwidth		400		MHz	-1dB Small Signal	
<b>REFERENCE INPUT, INTERNAL BANDGAP REFERENCE AND REFERENCE BUFFER</b>							
R <sub>LADDER</sub>	Ladder Resistance	100	125	150	Ohms	Note 1	
R <sub>SENSE</sub>	Sense Resistance		2		Ohms		
RLADTCO	Ladder Resistance Tempco		+0.8		Ohms/°C		
VBG	Bandgap Output Voltage Range	1.15	1.25	1.35	V		
VBGTC	Bandgap Reference Tempco		30		ppm/°C		
VRLF		0.0	0.0	2.0	V		
VRHF		VRLF+ 1.0		AVdd-0.3	V	Internal Reference Buffer	
VRHF	External Reference	VRLF+ 1.0	2.5	AVdd	V	External	
VRHF PSRR	Internal Reference Buffer		6		mV/V		
<b>VCMO, Common Mode Voltage</b>							
VCMO	Common Mode Voltage	1.15	1.25	1.35	V		
I <sub>SOURCE</sub>	Current Source	200	500		uA		

**Notes:**

<sup>1</sup> Full Scale ADC reference is VRHS - VRLS.

**ELECTRICAL CHARACTERISTICS TABLE (CONT'D)**

**Test Conditions (Unless Otherwise Specified)**

$T_A = 25^\circ\text{C}$   $AV_{DD} = DV_{DD} = +3.0\text{V}$ ,  $V_{IN} = \text{GND to } +2.5\text{V}$ ,  $V_{RLF} = \text{GND}$ ,  $V_{RHF} = +2.5\text{V}$  and  $F_s = 40\text{MSPS}$ , 50% Duty Cycle, Differential Input Mode

Symbol	Parameter	Min.	Typ.	Max.	Unit	Conditions
<b>DYNAMIC PERFORMANCE <math>F_s = 40\text{MHz}</math></b>						
SNR	Signal-to-Noise Ratio					Not Including Harmonics
	$f_{in} = 1.0\text{ MHz}$	58	60		dB	
	$f_{in} = 4.0\text{ MHz}$	57	60		dB	
	$f_{in} = 10.0\text{ MHz}$	57	59		dB	
SINAD	Signal-to Noise and Distortion					Including Harmonics
	$f_{in} = 1.0\text{ MHz}$	58	60		dB	
	$f_{in} = 4.0\text{ MHz}$	57	59		dB	
	$f_{in} = 10\text{ MHz}$	56	58		dB	
<b>ENOB EFFECTIVE NUMBER OF BITS</b>						
	$f_{in} = 1.0\text{ MHz}$	9.3	9.7		Bit	
	$f_{in} = 4.0\text{ MHz}$	9.2	9.5		Bit	
	$f_{in} = 10\text{ MHz}$	9.0	9.2		Bit	
<b>SFDR SPURIOUS FREE DYNAMIC RANGE</b>						
SFDR	$f_{in} = 1.0\text{ MHz}$		70		dB	
Crosstalk	$f_{in} = 1.0\text{ MHz}$		75		dB	
IMD	$f_{in1} = 2.5\text{ MHz}$		70		dB	Intermodulation Distortion
	$f_{in2} = 3.5\text{ MHz}$					
<b>CONVERSION AND TIMING CHARACTERISTICS (<math>C_L = 10\text{pF}</math>)</b>						
MAXCON	Maximum Conversion	40	50		MSPS	
MINCON	Minimum Conversion		100		KSPS	
Lat	Latency		17		cycles	Guaranteed by Design
APJT	Aperture Jitter Time		12		ps	Peak-to Peak
$t_r$	Digital Output Rise Time		3		ns	
$t_f$	Digital Output Fall Time		3		ns	
$t_{pd}$	Output Data Propagation Delay		6	25	ns	
$t_{den}$	Output Data Enable Delay		6	20	ns	Guaranteed by Design
$t_{dis}$	Output Data Disable Delay		5	20	ns	Guaranteed by Design
CLKDC	Clock Duty Cycle	40	50	60	%	Guaranteed by Design

## ELECTRICAL CHARACTERISTICS TABLE (CONT'D)

## Test Conditions (Unless Otherwise Specified)

$T_A = 25^\circ\text{C}$ ,  $AV_{DD} = DV_{DD} = +3.0\text{V}$ ,  $V_{IN} = \text{GND to } +2.5\text{V}$ ,  $V_{RLF} = \text{GND}$ ,  $V_{RHF} = +2.5\text{V}$  and  $F_s = 40 \text{ MSPS}$ , 50% Duty Cycle, Differential Input Mode

Symbol	Parameter	Min.	Typ.	Max.	Unit	Conditions
<b>DIGITAL INPUTS</b>						
DVINH	Digital Input High Voltage	2.5			V	
DVINL	Digital Input Low Voltage			0.5	V	
<b>DIINH</b>	<b>Digital Input High Leakage</b>					
CKIN	Clock Input	-1.0	0.05	1.0	$\mu\text{A}$	
DIFF	Differential/Single-Ended Input	-1.0	-0.25	1.0	$\mu\text{A}$	Internal pull-up resistor
TRI_A/TRI_B	A/B Channel Tri-State	-125.0	-90.0	-50.0	$\mu\text{A}$	Internal pull-down resistor
PD	Power Down	-125.0	-90.0	-50.0	$\mu\text{A}$	Internal pull-down resistor
<b>DIINL</b>	<b>Digital Input Low Leakage</b>					
CKIN	Clock Input	-5.0	0.05	5.0	nA	
DIFF	Differential/Single-Ended Input	50.0	90.0	125.0	$\mu\text{A}$	Internal pull-up resistor
TRI_A/TRI_B	A/B Channel Tri-State	-1.0	0.25	1.0	$\mu\text{A}$	Internal pull-down resistor
PD	Power Down	-1.0	0.25	1.0	$\mu\text{A}$	Internal pull-down resistor
DINC	Digital Input capacitance		5	8	pF	
<b>DIGITAL OUTPUTS (CL = 10 pF)</b>						
DOHV	Digital Output High Voltage	DVdd -0.4V	DVdd- 0.3V		V	IOH = 1.5 mA
DOLV	Digital Output Low Voltage		0.3	0.4	V	IOL = 1.5 mA
IOZ	High-Z Leakage	-100	0.2	100	nA	



## ELECTRICAL CHARACTERISTICS TABLE (CONT'D)

### Test Conditions (Unless Otherwise Specified)

$T_A = 25^\circ\text{C}$ ,  $AV_{DD} = DV_{DD} = +3.0\text{V}$ ,  $V_{IN} = \text{GND to } +2.5\text{V}$ ,  $V_{RLF} = \text{GND}$ ,  $V_{RHF} = +2.5\text{V}$  and  $F_s = 40 \text{ MSPS}$ , 50% Duty Cycle, Differential Input Mode

Symbol	Parameter	Min.	Typ.	Max.	Unit	Conditions
<b>POWER SUPPLIES</b>						
$AV_{DD}$	Analog Power Supply Voltage	2.7	3.0	3.3	V	
$DV_{DD}$	Digital Power Supply Range	2.7	$AV_{DD}$	3.3	V	$DV_{DD} = AV_{DD}$
<b><math>F_s = 40 \text{ MHz}</math>, <math>AV_{DD} = DV_{DD} = 2.7\text{V}</math>, <math>CL = 10\text{pF}</math>, <math>F_{in} = 10\text{MHz}</math> (Includes <math>I_{ref}</math> Current)</b>						
AIDD	Analog Supply Current		55		mA	
DIDD	Digital Supply Current		13		mA	
DOIDD	Output Driver Current		6		mA	
PDISS	Power Dissipation		200		mW	
<b><math>F_s = 40 \text{ MHz}</math>, <math>AV_{DD} = DV_{DD} = 3.3\text{V}</math>, <math>CL = 10\text{pF}</math>, <math>F_{in} = 10\text{MHz}</math> (Includes <math>I_{ref}</math> Current)</b>						
AIDD	Analog Supply Current		37	70	mA	
DIDD	Digital Supply Current		15	20	mA	
DOIDD	Output Driver Current		15	20	mA	
PDISS	Power Dissipation		225	365	mW	
<b>POWER DOWN CURRENT</b>						
IPD	Power Down Current		100	300	$\mu\text{A}$	

## ABSOLUTE MAXIMUM RATINGS ( $T_A = +25^\circ\text{C}$ unless otherwise noted)<sup>1, 2, 3</sup>

$V_{DD}$ to GND	+7.0V	Lead Temperature (Soldering 10 seconds)	300°C
$V_{RT}$ & $V_{RB}$	$V_{DD} + 0.5$ to GND - 0.5V	Maximum Junction Temperature	150°C
$V_{IN}$	$V_{DD} + 0.5$ to GND - 0.5V	Package Power Dissipation Ratings ( $T_A = +70^\circ\text{C}$ )	
All Inputs	$V_{DD} + 0.5$ to GND - 0.5V	TQFP	$\theta_{JA} = 89.4^\circ\text{C/W}$
All Outputs	$V_{DD} + 0.5$ to GND - 0.5V	ESD	2000V min
Storage Temperature	-65°C to 150°C		

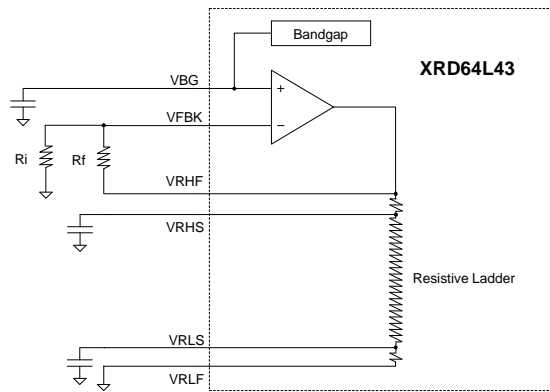
### Notes:

- <sup>1</sup> Stresses above those listed under "Absolute Maximum Ratings" may cause permanent damage to the device. This is a stress rating only and functional operation at or above this specification is not implied. Exposure to maximum rating conditions for extended periods may affect device reliability.
- <sup>2</sup> Any input pin which can see a value outside the absolute maximum ratings should be protected by Schottky diode clamps from input pin to the supplies. All inputs have protection diodes which will protect the device from short transients outside the supplies of less than 100mA for less than 100ms.
- <sup>3</sup>  $V_{DD}$  refers to  $AV_{DD}$  and  $DV_{DD}$ . GND refers to AGND and DGND

## APPLICATION SECTION

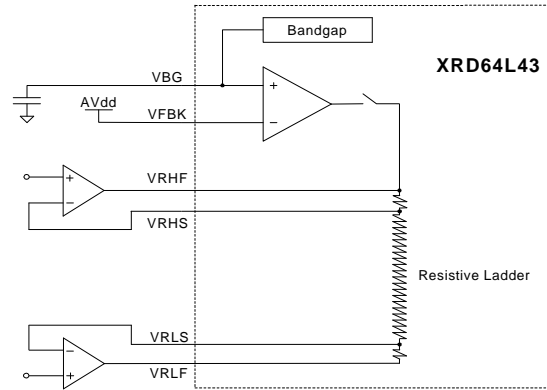
### Voltage References

The top ladder voltage for the XRD64L43 can be provided from an internal bandgap reference. The bandgap reference and its feedback path, Pins 1 and 2 respectively, can be used to set the voltage for VRHF. Select  $R_f$  and  $R_i$  (if gain is necessary) so that  $VRHF = VBG(1 + R_f/R_i)$ . The internal bandgap voltage is 1.24 volts. The XRD64L43 has a low impedance ladder, therefore, the typical value for  $R_f$  and  $R_i$  is 10K ( $R_f$  and  $R_i$  are recommended to be greater than 5K). See Figure 2. for a simplified diagram. Decoupling caps on the sense inputs to AGND should be used to reduce injection of high-frequency noise.



**Figure 2. Voltage Reference Generated from the Internal Bandgap Voltage/gain**

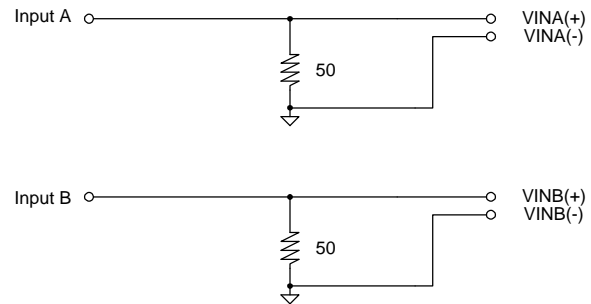
External voltage references can be forced at VRHF and VRLF. If VRHF and VRLF are driven externally, VFBK should be connected to AVdd, which tri-states the bandgap reference. Direct inputs or inputs driven by external amplifiers can be used to drive the ladder reference voltages of the XRD64L43. See Figure 3. for a simplified diagram. The sense inputs are intended for sensing purposes only and care must be taken to insure that no current flow be present in the sense lines.



**Figure 3. Voltage Reference Provided by an External Source as Direct Inputs**

### Single-Ended Inputs

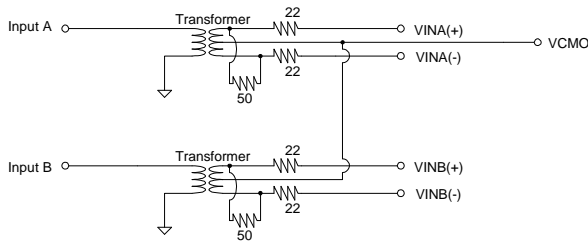
The XRD64L43 can be used in either single-ended or differential input mode. For differential inputs, see the Differential Inputs Section. Single-ended inputs minimize the amount of external components necessary to interface with the XRD64L43. The common inputs, VINA(-) and VINB(-) should be tied to ground. VINA(+) and VINB(+) can be used to apply direct inputs to the XRD64L43. Figure 4. is a simplified diagram for single-ended inputs. Pin 16, DIFF should be held low to select single-ended inputs.



**Figure 4. Single-Ended Inputs for the XRD64L43**

**Differential Inputs**

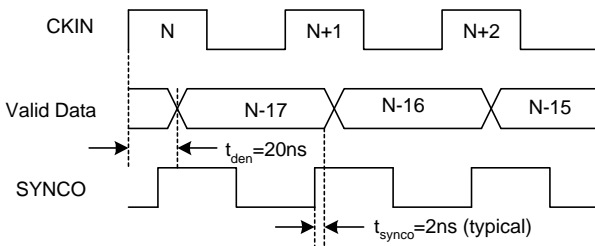
The XRD64L43 can be used in either differential or single-ended input mode. For single-ended inputs, see the Single-Ended Inputs Section. Differential inputs reduce system noise by removing noise components common at both input pins. Figure 5. is a simplified diagram that is used as a common test circuit with our XRD64L43ES application board. This circuit is used to evaluate the dynamic performance of the XRD64L43 using differential inputs. Pin 16, DIFF should be held high to select differential inputs.



**Figure 5. Common Test Circuit for the Differential Input Mode**

**SYNCO, Data Valid Delay and Latency**

SYNCO is an output pin provided by the XRD64L43. Valid data is available on the rising edge of SYNCO, see Figure 6. The Latency for the XRD64L43 is 17 clock cycles.



**Figure 6. SYNCO, Data Valid Delay and Latency for the XRD64L43**

**Auto-Calibration**

The XRD64L43 incorporates an auto-calibration circuit which continuously adjusts and matches the offset and linearity of each ADC. This auto-calibration circuit is transparent to the user after the initial 4.2ms calibration (168,000 initial clock cycles).

*Note: To avoid auto-calibration after power down, do not disable CKIN. CKIN can be slowed down significantly to save power without losing calibration.*



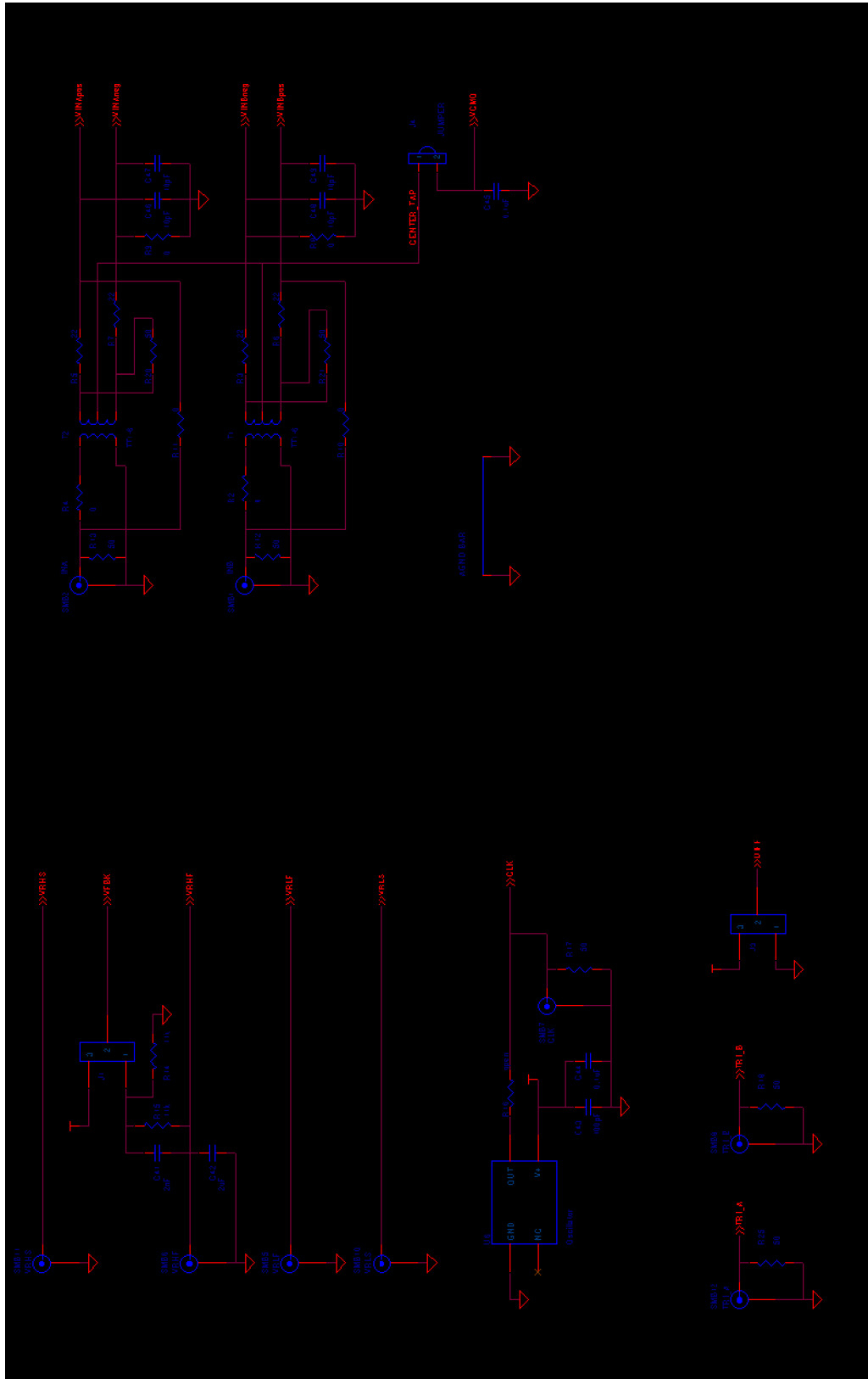


Figure 7b. XRD64L43ES - Application Circuit for the XRD64L43

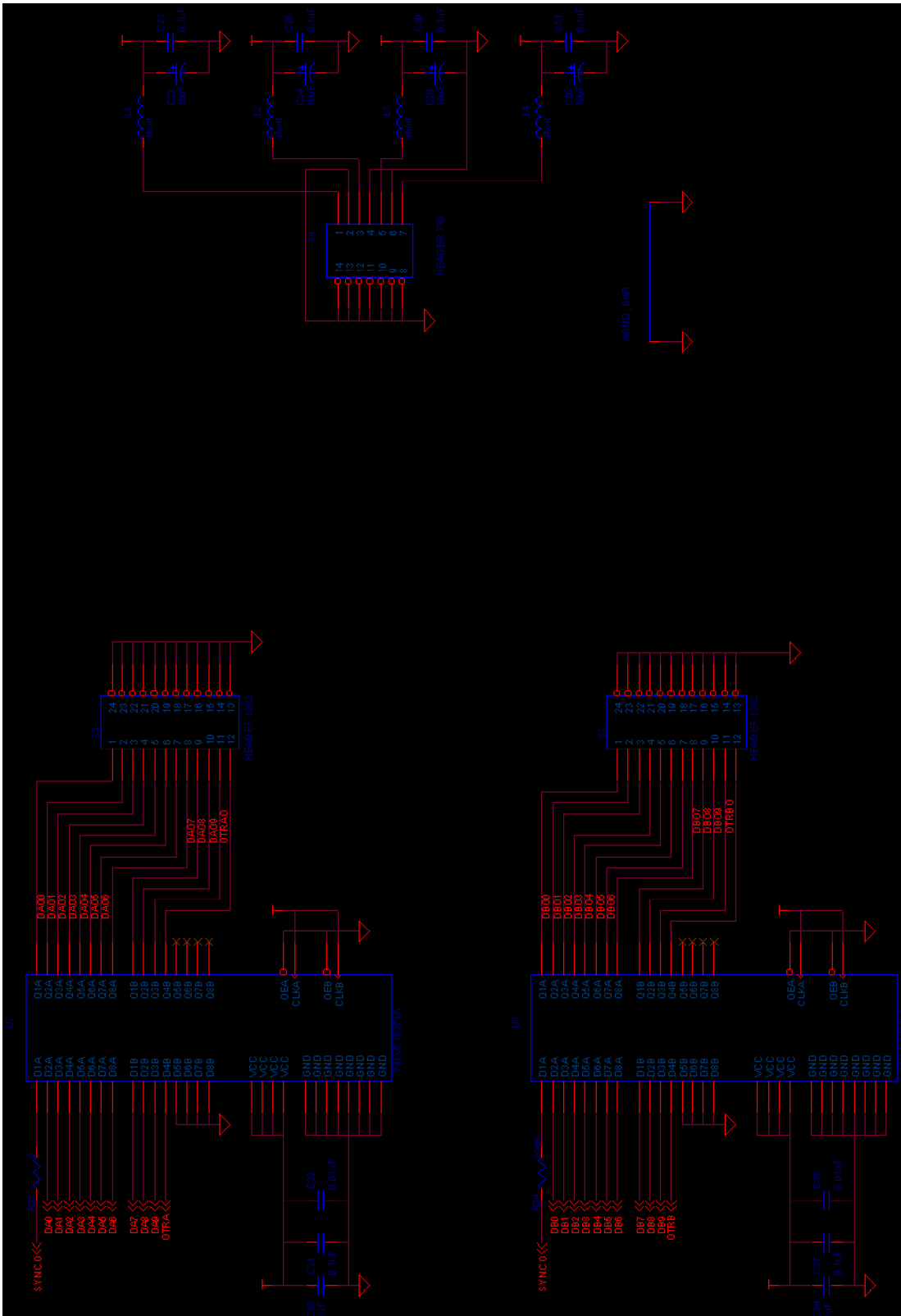
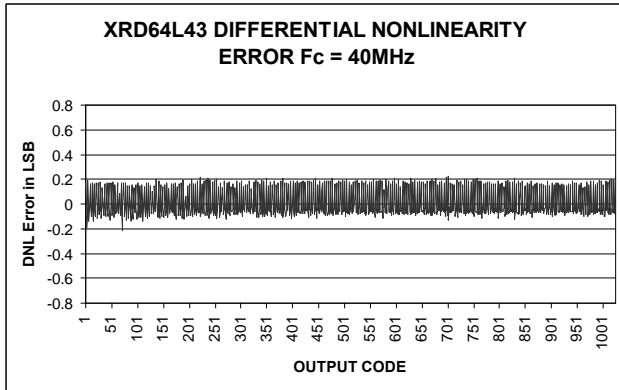
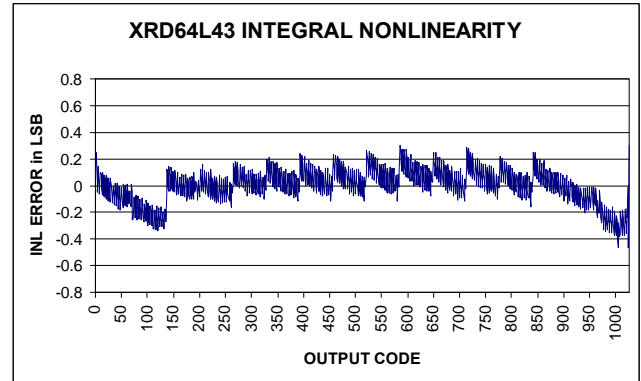


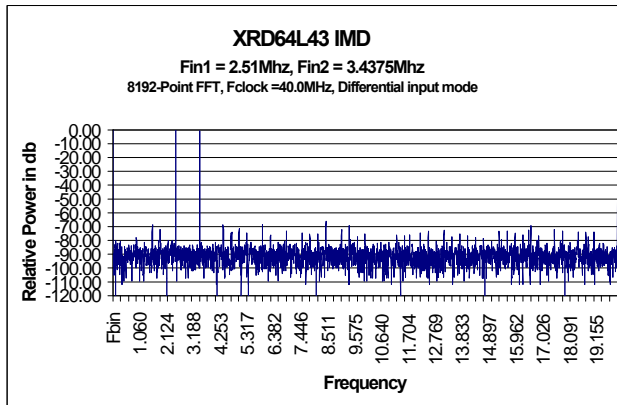
Figure 7c. XRD64L43ES - Application Circuit for the XRD64L43



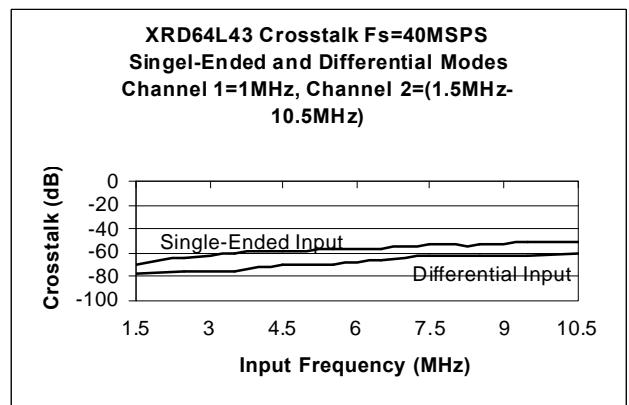
**Figure 8. Differential Non-Linearity, Differential Input Mode, Fc=40MHz, Fin=1.5kHz, VRHF=2.5V, V<sub>DD</sub>=3V**



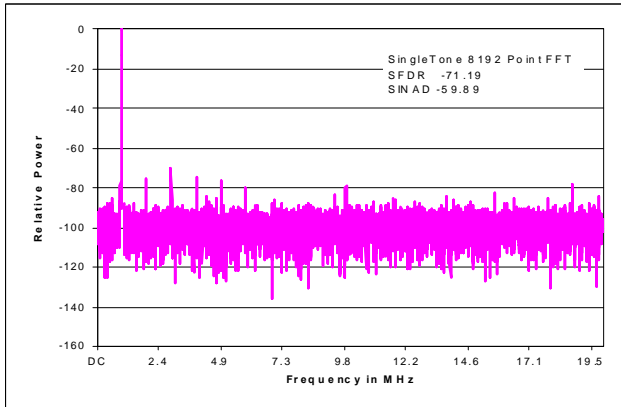
**Figure 9. Integral Non-Linearity, Differential Input Mode, Fc=40MHz, Fin=1.5kHz, VRHF=2.5V, V<sub>DD</sub>=3V**



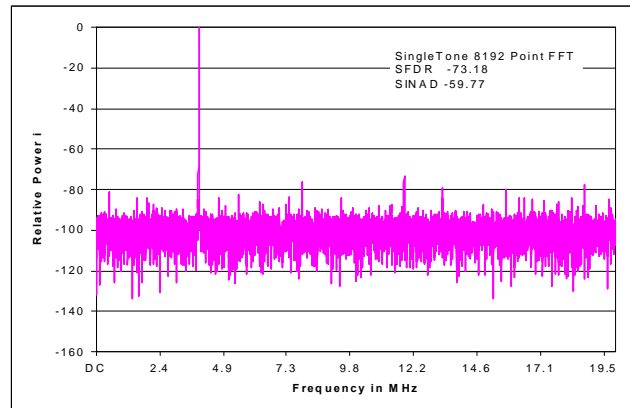
**Figure 10. Intermodulation Distortion, Fin1=2.51MHz, Fin2=3.4375MHz, 8192-point FFT, Fc=40MHz, Differential Input Mode**



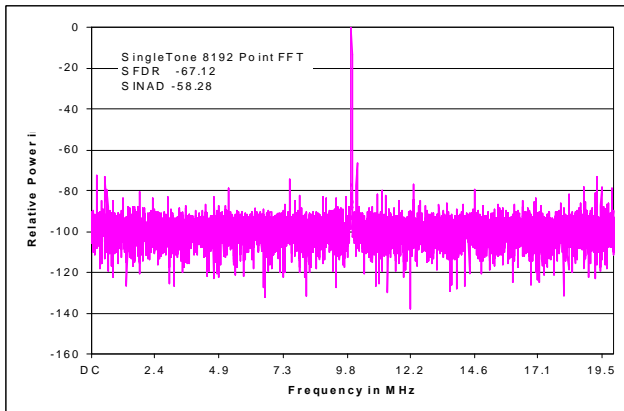
**Figure 11. Crosstalk vs Input Frequency, V<sub>DD</sub>=3V, Differential and Single Ended Inputs**



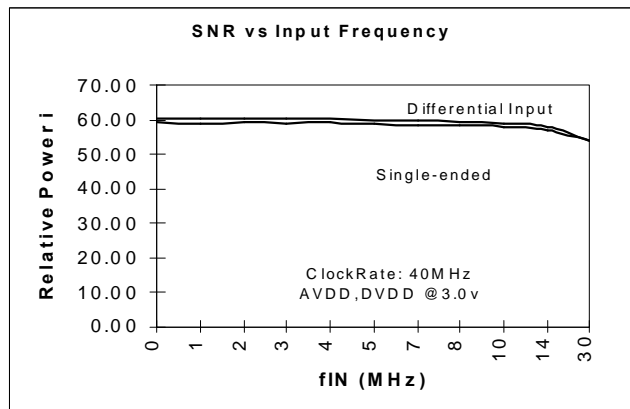
**Figure 12. FFT Spectrum @Fclock = 40.0MHz, Fin = 1.0MHz, DIFFERENTIAL INPUT MODE**



**Figure 13. FFT Spectrum @Fclock = 40.0MHz, Fin = 4.0MHz, DIFFERENTIAL INPUT MODE**

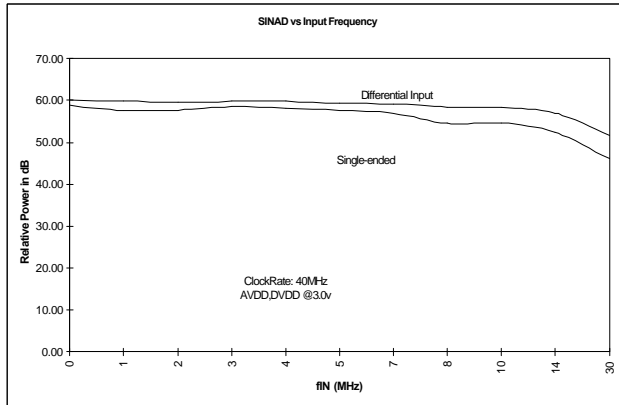


**Figure 14. FFT Spectrum @Fclock = 40.0MHz, Fin = 10.0MHz, DIFFERENTIAL INPUT MODE**

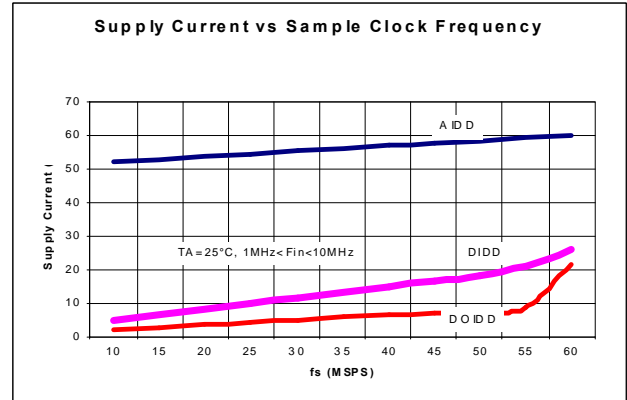


**Figure 15. SNR vs Input Frequency, Differential and Single Ended Inputs,  $V_{DD}=3V$**

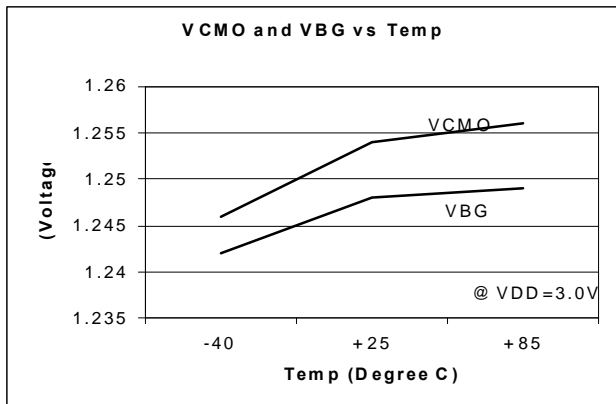




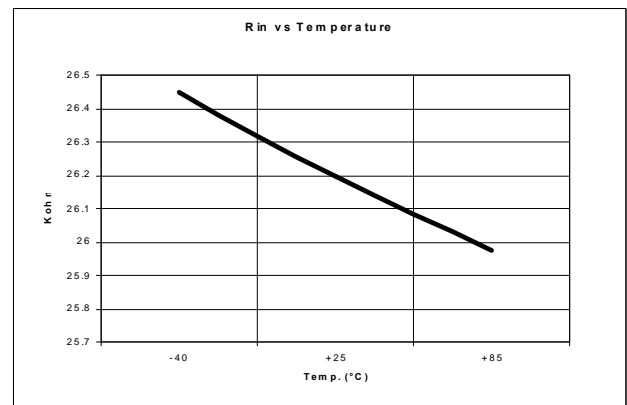
**Figure 16. SINAD vs Input Frequency, Differential and Single Ended Inputs,  $V_{DD}=3V$**



**Figure 17. Supply Current vs Sample Clock Frequency**



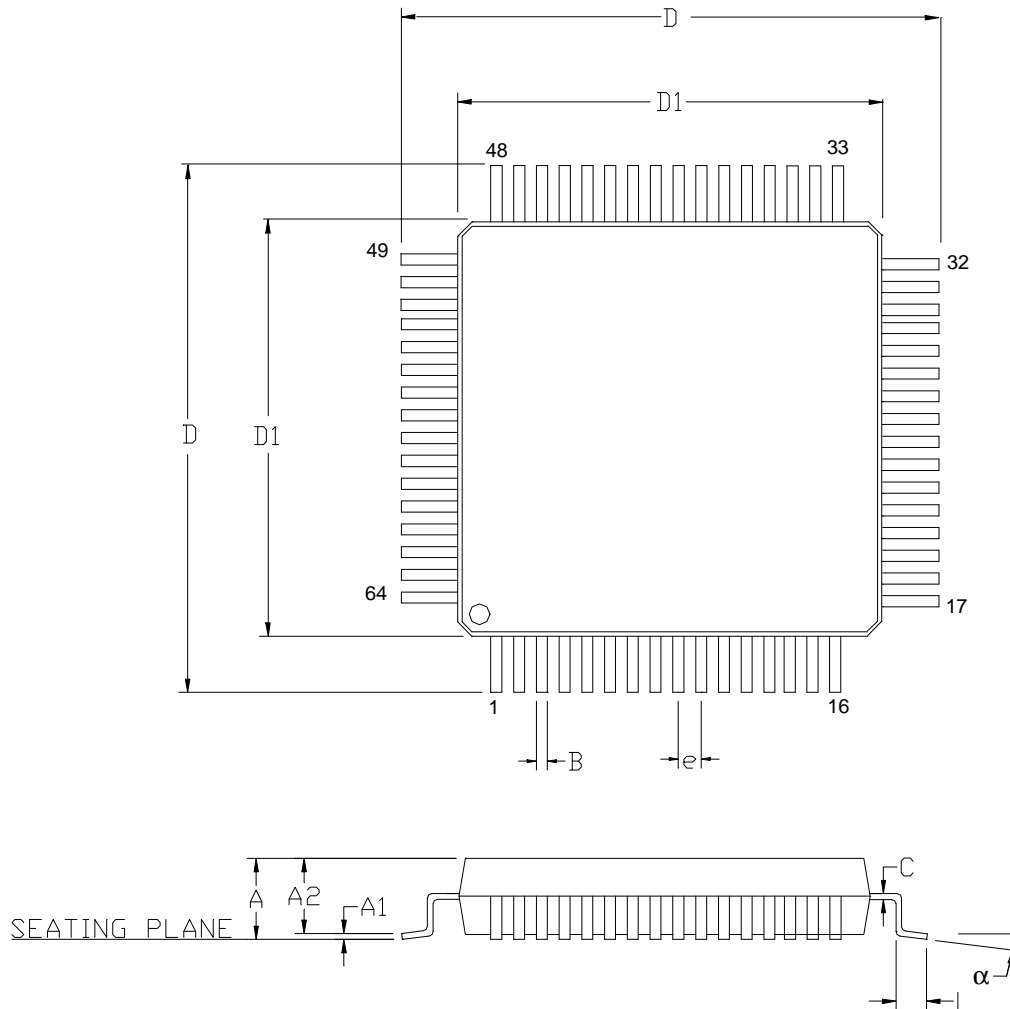
**Figure 18. VCMO and VBG vs Temperature**



**Figure 19. Rin of VINA+, VINB+ vs Temperature at  $F_c=40MSPS$**

## 64 LEAD LOW-PROFILE QUAD FLAT PACK (10 mm x 10 mm X 1.4 mm LQFP, 1.0 mm Form)

Rev. 3.00



Note: The control dimension is in millimeters.

SYMBOL	INCHES		MILLIMETERS	
	MIN	MAX	MIN	MAX
A	0.055	0.063	1.40	1.60
A1	0.002	0.006	0.05	0.15
A2	0.053	0.057	1.35	1.45
B	0.007	0.011	0.17	0.27
C	0.004	0.008	0.09	0.20
D	0.465	0.480	11.80	12.20
D1	0.390	0.398	9.90	10.10
e	0.020	BSC	0.50	BSC
L	0.018	0.030	0.45	0.75
$\alpha$	0°	7°	0°	7°



**Notes**



**NOTICE**

EXAR Corporation reserves the right to make changes to the products contained in this publication in order to improve design, performance or reliability. EXAR Corporation assumes no responsibility for the use of any circuits described herein, conveys no license under any patent or other right, and makes no representation that the circuits are free of patent infringement. Charts and schedules contained here in are only for illustration purposes and may vary depending upon a user's specific application. While the information in this publication has been carefully checked; no responsibility, however, is assumed for inaccuracies.

EXAR Corporation does not recommend the use of any of its products in life support applications where the failure or malfunction of the product can reasonably be expected to cause failure of the life support system or to significantly affect its safety or effectiveness. Products are not authorized for use in such applications unless EXAR Corporation receives, in writing, assurances to its satisfaction that: (a) the risk of injury or damage has been minimized; (b) the user assumes all such risks; (c) potential liability of EXAR Corporation is adequately protected under the circumstances.

Copyright 2000 EXAR Corporation  
Datasheet July 2003

Reproduction, in part or whole, without the prior written consent of EXAR Corporation is prohibited.

## Данный компонент на территории Российской Федерации

### Вы можете приобрести в компании MosChip.

Для оперативного оформления запроса Вам необходимо перейти по данной ссылке:

<http://moschip.ru/get-element>

Вы можете разместить у нас заказ для любого Вашего проекта, будь то серийное производство или разработка единичного прибора.

В нашем ассортименте представлены ведущие мировые производители активных и пассивных электронных компонентов.

Нашей специализацией является поставка электронной компонентной базы двойного назначения, продукции таких производителей как XILINX, Intel (ex.ALTERA), Vicor, Microchip, Texas Instruments, Analog Devices, Mini-Circuits, Amphenol, Glenair.

Сотрудничество с глобальными дистрибьюторами электронных компонентов, предоставляет возможность заказывать и получать с международных складов практически любой перечень компонентов в оптимальные для Вас сроки.

На всех этапах разработки и производства наши партнеры могут получить квалифицированную поддержку опытных инженеров.

Система менеджмента качества компании отвечает требованиям в соответствии с ГОСТ Р ИСО 9001, ГОСТ РВ 0015-002 и ЭС РД 009

### Офис по работе с юридическими лицами:

105318, г.Москва, ул.Щербаковская д.3, офис 1107, 1118, ДЦ «Щербаковский»

Телефон: +7 495 668-12-70 (многоканальный)

Факс: +7 495 668-12-70 (доб.304)

E-mail: [info@moschip.ru](mailto:info@moschip.ru)

Skype отдела продаж:

moschip.ru

moschip.ru\_4

moschip.ru\_6

moschip.ru\_9