

6-CHANNEL LIGHT EFFECT LED DRIVER

DESCRIPTION

IS31FL3196A is a 6-channel light effect LED driver which features two-dimensional auto breathing mode and an audio modulated display mode. It has One Shot Programming Mode and PWM Control Mode for RGB lighting effects. The maximum output current can be adjusted in 8 levels (5mA~40mA).

FEATURES

- Supply voltage range from 2.7V to 5.5V
- Two groups RGB, single color LED breathing system-free pre-established pattern
- 6 independently controlled automatic and semiautomatic breathing system-free pre-established pattern
- 6 independently controlled outputs of 256 PWM steps
- 8 levels programmable output current
- Audio mode with AGC function
- Cascade for the synchronization of chips
- QFN-20 (3mm × 3mm) package

QUICK START



Figure 1: Photo of IS31FL3196A Evaluation Board

RECOMMENDED EQUIPMENT

- 5.0V, 2A power supply

ABSOLUTE MAXIMUM RATINGS

- $\leq 5.5V$ power supply

Caution: Do not exceed the conditions listed above, otherwise the board will be damaged.

PROCEDURE

The IS31FL3196A evaluation board is fully assembled and tested. Follow the steps listed below to verify board operation.

Caution: Do not turn on the power supply until all connections are completed.

- 1) Short JP1 to connect by board MCU (default short).
- 2) Connect the 5VDC power to the connector (TP1&TP2) (Skip this step if use Micro-USB as power input).
- 3) Turn on the power supply/Plug in the Micro USB Pay attention to the supply current. If the current exceeds 1A, please check for circuit fault.

EVALUATION BOARD OPERATION

The IS31FL3196A evaluation board has five display modes. Press K1 to switch configurations.

- 1) 6 lamps breathe at the same time
- 2) The RGB monochromatic breathes
- 3) RGB audio mode
- 4) 6 lamps breathe one by one
- 5) 6 lamps audio mode

Note: IS31FL3196A solely controls the FxLED function on the evaluation board.

ORDERING INFORMATION

Part No.	Temperature Range	Package
IS31FL3196A-QFLS2-EB	-40°C ~ +85°C (Industrial)	QFN-20, Lead-free

Table 1: Ordering Information

For pricing, delivery, and ordering information, please contact ISSI's analog marketing team at analog@issi.com or (408) 969-6600.

6-CHANNEL LIGHT EFFECT LED DRIVER

SOFTWARE CONTROL

J1 default setting is closed (short). If it is set to open, the MCU's SDB, SCL, SDA and CLK pin will be high impedance (open-drain) and external control is allowed.

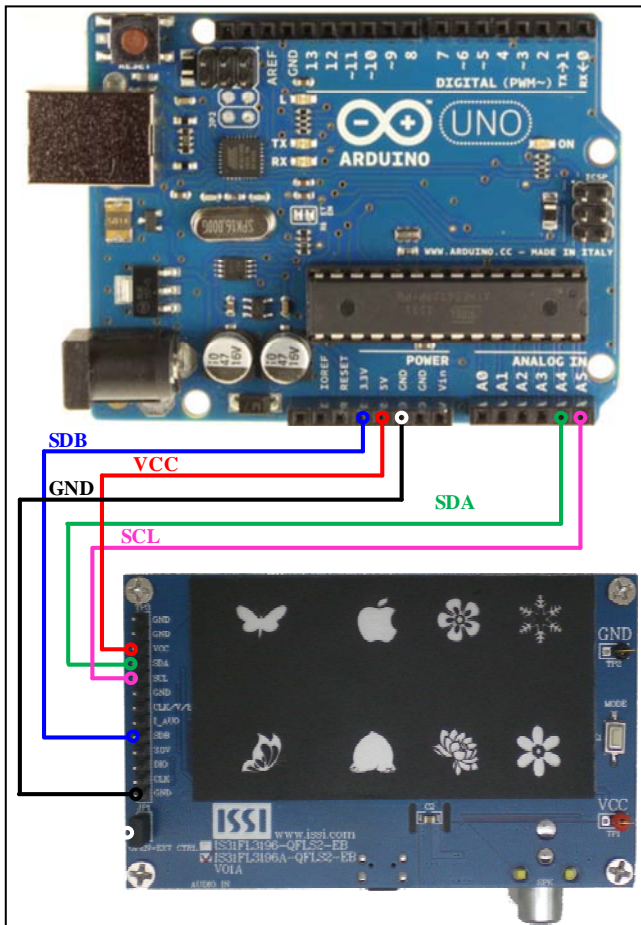

Figure 2: Photo of Arduino UNO connected to Evaluation Board

The steps listed below are an example using the Arduino for external control.

The Arduino hardware consists of an Atmel microcontroller with a bootloader allowing quick firmware updates. First download the latest Arduino Integrated Development Environment IDE (1.6.12 or greater) from www.arduino.cc/en/Main/Software. Also download the Wire.h library from www.arduino.cc/en/reference/wire and verify that pgmspace.h is in the directory ...program Files(x86)/Arduino/hardware/tools/avr/avr/include/avr/. Then download the latest IS31FL3196A test firmware (sketch) from the ISSI website <http://www.issi.com/US/product-analog-fxled-drivershtml>.

- 1) Open JP1.
- 2) Connect the 5 pins from Arduino board to IS31FL3196A EVB:
 - a) Arduino 5V pin to IS31FL3196A EVB VCC.
 - b) Arduino GND to IS31FL3196A EVB GND.
 - c) Arduino SDA (A4) to IS31FL3196A EVB SDA.
 - d) Arduino SCL (A5) to IS31FL3196A EVB SCL.
 - e) If Arduino use 3.3V MCU VCC, connect 3.3V to IS31FL3196A EVB SDB, if Arduino use 5.0V MCU VCC, connect 5.0V to EVB SDB.
(Arduino UNO is 5.0V, so SDB=5.0V)
- 3) Use the test code in appendix I or download the test firmware (sketch) from the ISSI website, a .txt file and copy the code to Arduino IDE, compile and upload to Arduino.
- 4) Run the Arduino code and the initial mode will change the RGB LED brightness every second. Note: the white color LEDs cannot be controlled when the onboard STM32F103C8T6 is disabled. (Some early board we provided is still controlling the white color LED, if want to switch between single color LED and RGB, remove the U4 and connect the VCC to the LED+)

Please refer to the datasheet to get more information about IS31FL3196A.

6-CHANNEL LIGHT EFFECT LED DRIVER

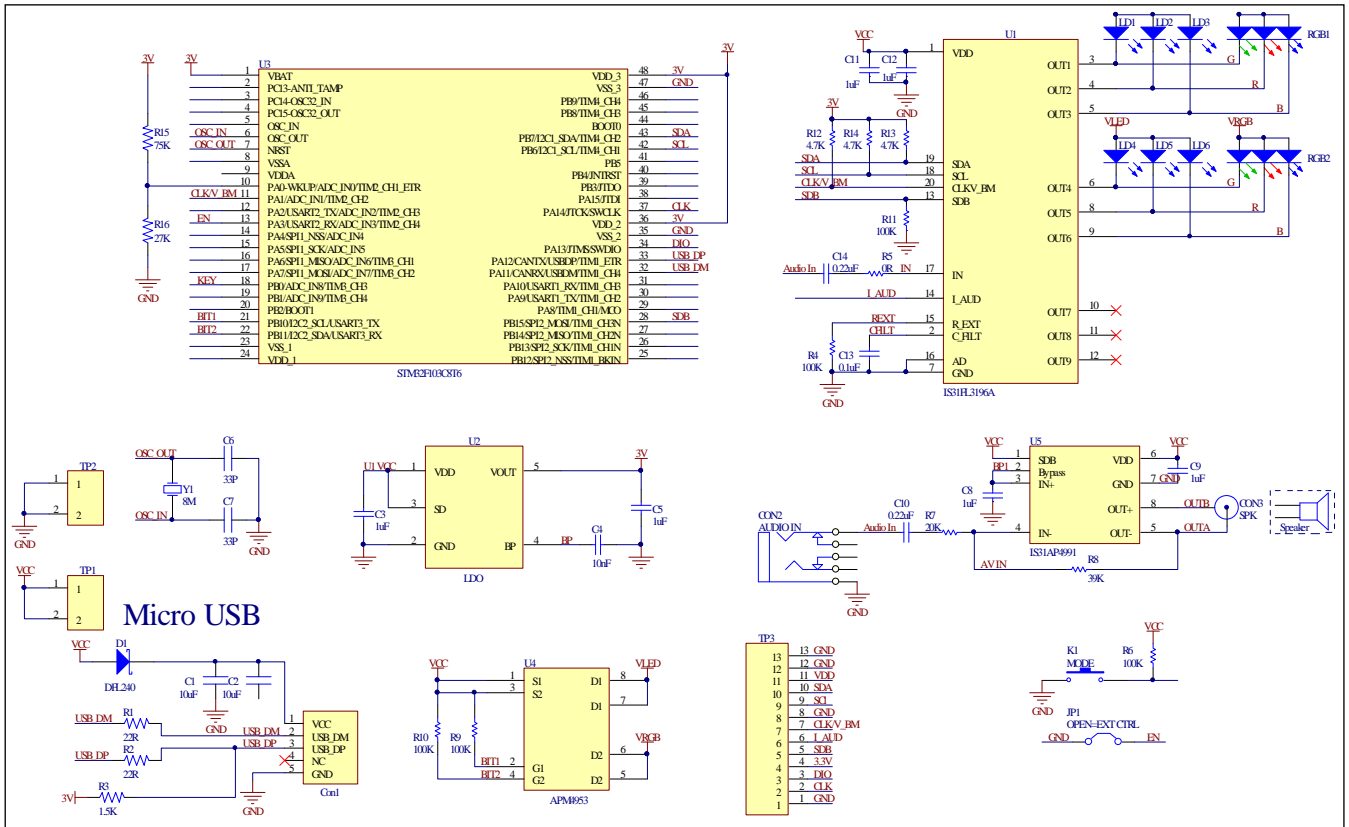

Figure 3: IS31FL3196A Application Schematic

6-CHANNEL LIGHT EFFECT LED DRIVER

BILL OF MATERIALS

Name	Symbol	Description	Qty	Supplier	Part No.
LED Driver	U1	Matrix LED Driver	1	ISSI	IS31FL3196A
LDO	U2	3.0V LDO	1	SGMICRO	SGM2019-3.0YN5G
MCU	U3	Microcontroller	1	STM	STM32F103C8T6
PMOS	U4	PMOS	1	ANPEC	APM4953
AMP	U5	Audio power amplifier	1	ISSI	IS31AP4991
LED	LD1~LD6	Blue LED,SMD	6	Everlight	9-217/BHC-ZL1M2RY/3T
LED	RGB1,RGB2	RGB LED,SMD	2	Everlight	99-235/RGBC/TR8
Diode	D1	Diode,SMD	1	Diodes In	DFLS240
Crystal	Y1	Crystal,8MHz	1	HLX	HC-49S
Resistor	R1,R2	RES,22R,1/16W,±5%,SMD	2	Yageo	RC0603JR-0722RL
Resistor	R3	RES,1.5k,1/16W,±5%,SMD	1	Yageo	RC0603JR-071K5L
Resistor	R4,R6,R9, R10,R11	RES,100k,1/16W,±5%,SMD	5	Yageo	RC0603JR-07100KL
Resistor	R5	RES,0R,1/16W,±5%,SMD	1	Yageo	RC0603JR-07000KL
Resistor	R7	RES,20k,1/16W,±5%,SMD	1	Yageo	RC0603JR-0720KL
Resistor	R8	RES,39k,1/16W,±5%,SMD	1	Yageo	RC0603JR-0739KL
Resistor	R12,R13,R14	RES,4.7k,1/16W,±5%,SMD	3	Yageo	RC0603JR-0704K7L
Resistor	R15	RES,75k,1/16W,±5%,SMD	1	Yageo	RC0603JR-0775KL
Resistor	R16	RES,27k,1/16W,±5%,SMD	1	Yageo	RC0603JR-0727KL
Capacitor	C1,C2	CAP,10µF,16V,±20%,SMD	2	Yageo	CC0603KKX7R9BB106
Capacitor	C3,C5,C8, C9,C11	CAP,1µF,16V,±20%,SMD	6	Yageo	CC0603KKX7R9BB105
Capacitor	C4	CAP,10nF,16V,±20%,SMD	1	Yageo	CC0603KKX7R9BB103
Capacitor	C6,C7	CAP,33pF,16V,±20%,SMD	2	Yageo	CC0603KKX7R9BB330
Capacitor	C10,C14	CAP,0.22µF,16V,±20%,SMD	2	Yageo	CC0603KKX7R9BB224
Capacitor	C12,C13	CAP,0.1µF,16V,±20%,SMD	2	Yageo	CC0603KKX7R9BB104
Button	K1	Button SMD	1		

Bill of Materials, refer to Figure 3 above.

6-CHANNEL LIGHT EFFECT LED DRIVER

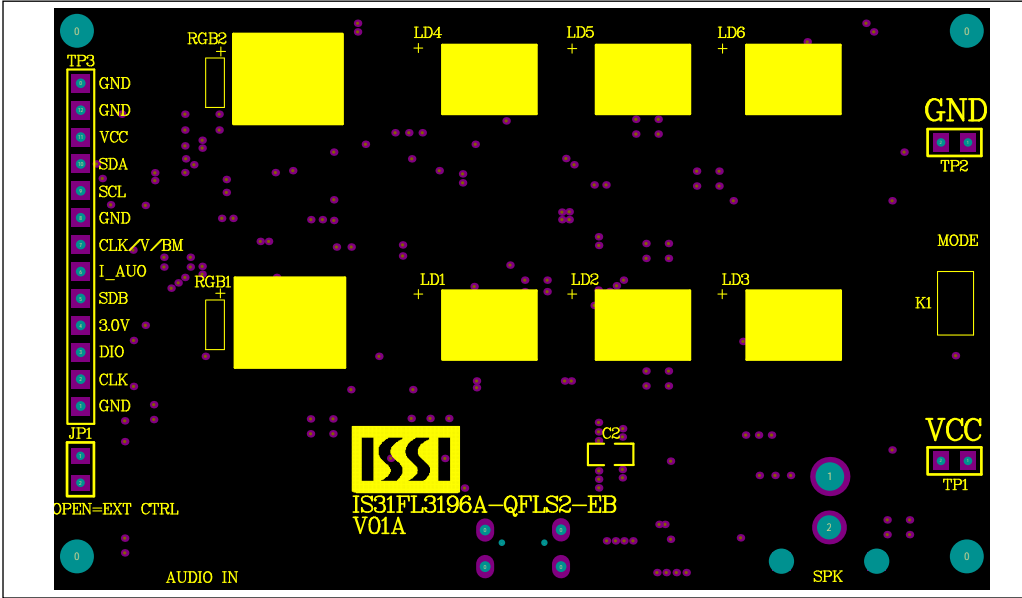

Figure 4: Board Component Placement Guide - Top Layer

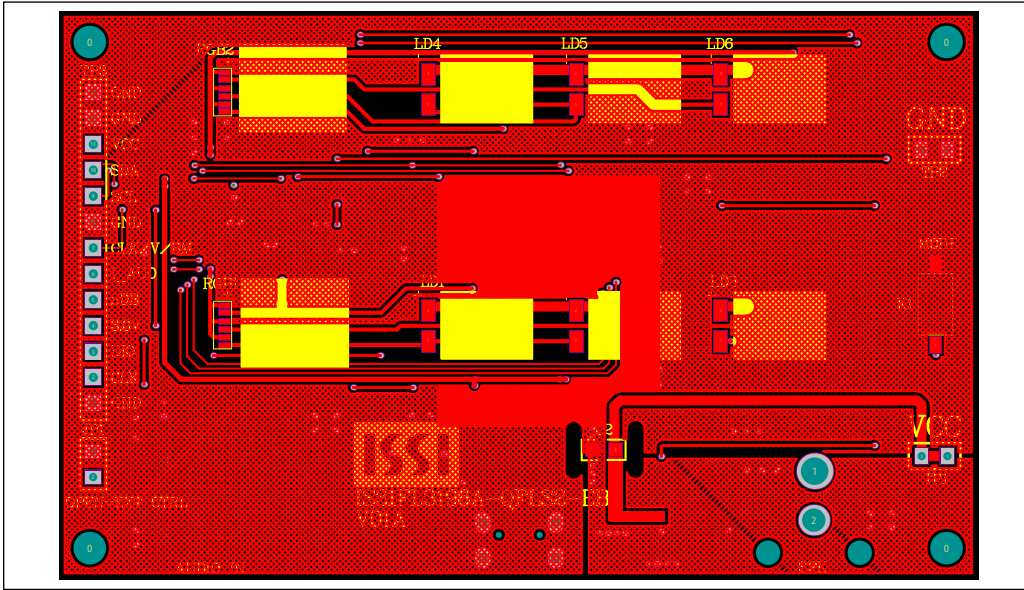

Figure 5: Board PCB Layout - Top Layer

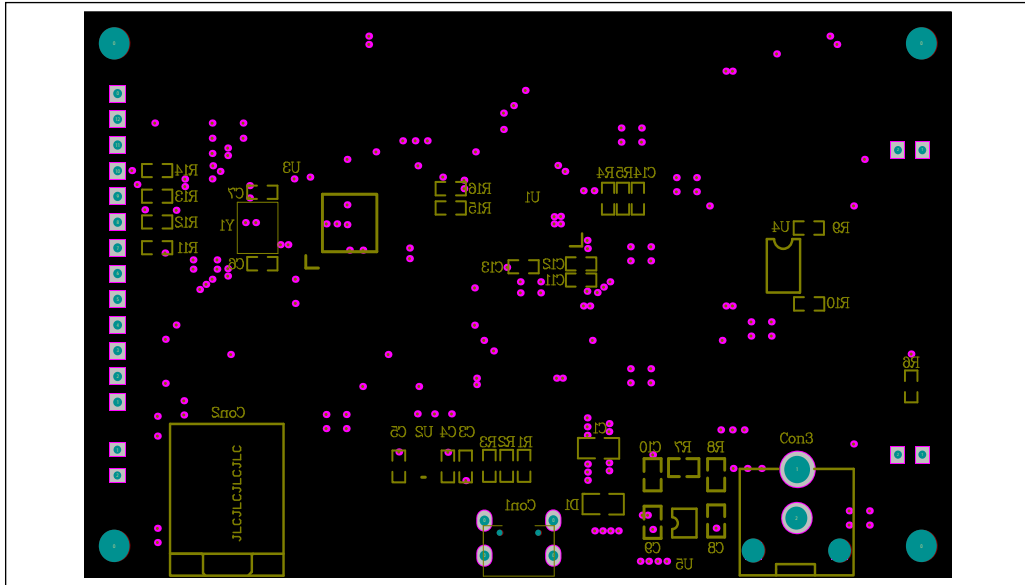

Figure 6: Board Component Placement Guide - Bottom Layer

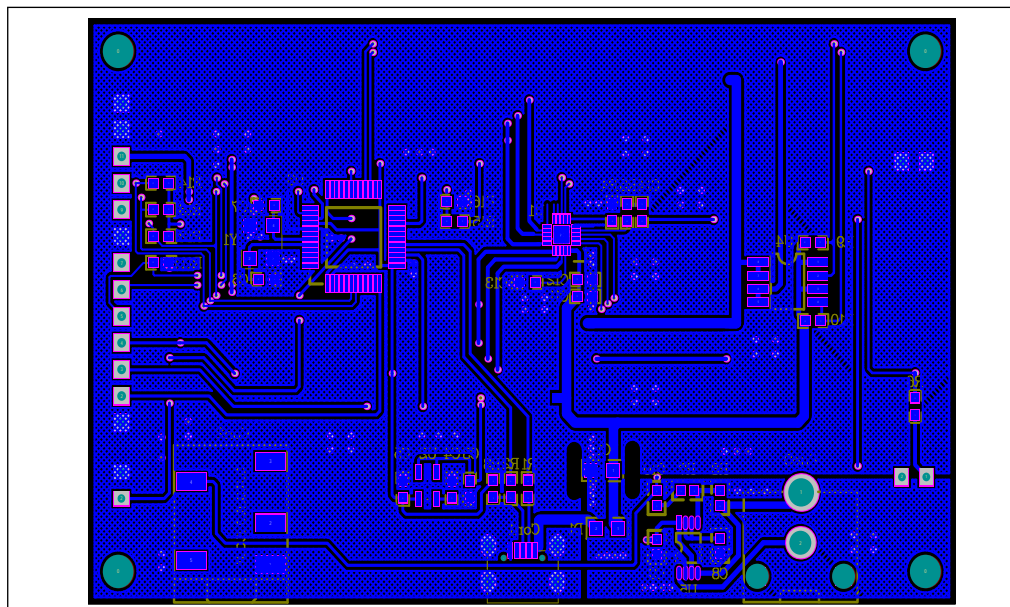

Figure 7: Board PCB Layout - Bottom Layer

Copyright © 2017 Integrated Silicon Solution, Inc. All rights reserved. ISSI reserves the right to make changes to this specification and its products at any time without notice. ISSI assumes no liability arising out of the application or use of any information, products or services described herein. Customers are advised to obtain the latest version of this device specification before relying on any published information and before placing orders for products. Integrated Silicon Solution, Inc. does not recommend the use of any of its products in life support applications where the failure or malfunction of the product can reasonably be expected to cause failure of the life support system or to significantly affect its safety or effectiveness. Products are not authorized for use in such applications unless Integrated Silicon Solution, Inc. receives written assurance to its satisfaction, that:

- a.) the risk of injury or damage has been minimized;
- b.) the user assume all such risks; and
- c.) potential liability of Integrated Silicon Solution, Inc is adequately protected under the circumstances



6-CHANNEL LIGHT EFFECT LED DRIVER

REVISION HISTORY

Revision	Detail Information	Data
B	Initial release	2017.02.23
C	Remove IS31FL3196 description	2017.08.22

APPENDIX I : IS31FL3196A Arduino Test Code V01A

```

#include<Wire.h>
#include<avr/pgmspace.h>
#define Addr_GND 0xC8//7 bit format is 0x64
#define Addr_VCC 0xCE//7 bit format is 0x67
#define Addr_SCL 0xCA//7 bit format is 0x65
#define Addr_SDA 0xCC//7 bit format is 0x66

int i,j;

byte PWM_Gamma64[64]=
{
  0x00,0x01,0x02,0x03,0x04,0x05,0x06,0x07,
  0x08,0x09,0x0b,0x0d,0x0f,0x11,0x13,0x16,
  0x1a,0x1c,0x1d,0x1f,0x22,0x25,0x28,0x2e,
  0x34,0x38,0x3c,0x40,0x44,0x48,0x4b,0x4f,
  0x55,0x5a,0x5f,0x64,0x69,0x6d,0x72,0x77,
  0x7d,0x80,0x88,0x8d,0x94,0x9a,0xa0,0xa7,
  0xac,0xb0,0xb9,0xbf,0xc6,0xcb,0xcf,0xd6,
  0xe1,0xe9,0xed,0xf1,0xf6,0xfa,0xfe,0xff
};

void setup() {
  // put your setup code here, to run once:
  Wire.begin();
  Wire.setClock(400000);//I2C 400kHz
  // pinMode(4,OUTPUT);//SDB
  // digitalWrite(4,HIGH);//SDB_HIGH
  IS31FL3196A_mode2();
}

void loop()
{
  // put your main code here, to run repeatedly:
  //IS31FL3196A_mode1();//PWM mode, if enable this mode, need to disable IS31FL3196A_mode2
}

void IS_IIC_WriteByte(uint8_t Dev_Add,uint8_t Reg_Add,uint8_t Reg_Dat)
{
  Wire.beginTransmission(Dev_Add/2);
  Wire.write(Reg_Add); // sends regaddress
  Wire.write(Reg_Dat); // sends regaddress
  Wire.endTransmission(); // stop transmitting
}

void Init_FL3196A(void)
{
  IS_IIC_WriteByte(Addr_GND,0x00,0x01);//normal operation
  IS_IIC_WriteByte(Addr_GND,0x01,0x77);//on/off
  IS_IIC_WriteByte(Addr_GND,0x03,0x00);
  IS_IIC_WriteByte(Addr_GND,0x04,0x00);
  for(i=0x07;i<0x0F;i++){IS_IIC_WriteByte(Addr_GND, i, 0x00);}//PWM data
  IS_IIC_WriteByte(Addr_GND, 0x10, 0x00);//update
}

void Rgb_Pwm_Control_FL3196(uint8_t datx,uint8_t datR,uint8_t datG,uint8_t datB)//datx RGBx
{
  switch(datx)
  {
    case 1:IS_IIC_WriteByte(Addr_GND, 0x07, datG);//set out1 pwm G
            IS_IIC_WriteByte(Addr_GND, 0x08, datR);//set out2 pwm R
            IS_IIC_WriteByte(Addr_GND, 0x09, datB);//set out3 pwm B
            break;
    case 2:IS_IIC_WriteByte(Addr_GND, 0x0A, datG);//set out4 pwm G
            IS_IIC_WriteByte(Addr_GND, 0x0B, datR);//set out5 pwm R
            IS_IIC_WriteByte(Addr_GND, 0x0C, datB);//set out6 pwm B
            break;
    default:break;
  }
  IS_IIC_WriteByte(Addr_GND, 0x10, 0x00);//update PWM registers
}

```

6-CHANNEL LIGHT EFFECT LED DRIVER

```

void IS31FL3196A_mode1(void)//need to run in loop
{
  Init_FL3196A();
  for (j=0;j<64;j++)//all LED ramping up
  {
    Rgb_Pwm_Control_FL3196(1, PWM_Gamma64[j],PWM_Gamma64[j],PWM_Gamma64[j]);
    Rgb_Pwm_Control_FL3196(2, PWM_Gamma64[j],PWM_Gamma64[j],PWM_Gamma64[j]);
    delay(10);//10ms
  }
  delay(1000); //keep on 1s
  for (j=63;j>=0;j--)//all LED ramping down
  {
    Rgb_Pwm_Control_FL3196(1, PWM_Gamma64[j],PWM_Gamma64[j],PWM_Gamma64[j]);
    Rgb_Pwm_Control_FL3196(2, PWM_Gamma64[j],PWM_Gamma64[j],PWM_Gamma64[j]);
    delay(10);//10ms
  }
  delay(1000); //keep off 1s
}
void IS31FL3196A_mode2(void)//One shot mode, only in setup
{
  IS_IIC_WriteByte(Addr_GND,0x00,0x01);//normal operation
  IS_IIC_WriteByte(Addr_GND,0x01,0x77);//on/off
  IS_IIC_WriteByte(Addr_GND,0x04,0x00);

  IS_IIC_WriteByte(Addr_GND,0x07,0xff);//PWM
  IS_IIC_WriteByte(Addr_GND,0x08,0xff);
  IS_IIC_WriteByte(Addr_GND,0x09,0xff);
  IS_IIC_WriteByte(Addr_GND,0x0a,0xff);
  IS_IIC_WriteByte(Addr_GND,0x0b,0xff);
  IS_IIC_WriteByte(Addr_GND,0x0c,0xff);
  IS_IIC_WriteByte(Addr_GND,0x10,0x00);//update PWM registers

  IS_IIC_WriteByte(Addr_GND,0x11,0x00);//T0
  IS_IIC_WriteByte(Addr_GND,0x12,0x01);
  IS_IIC_WriteByte(Addr_GND,0x13,0x02);
  IS_IIC_WriteByte(Addr_GND,0x14,0x05);
  IS_IIC_WriteByte(Addr_GND,0x15,0x04);
  IS_IIC_WriteByte(Addr_GND,0x16,0x03);

  IS_IIC_WriteByte(Addr_GND,0x1a,0xa0);//T1~T3
  IS_IIC_WriteByte(Addr_GND,0x1b,0xa0);

  IS_IIC_WriteByte(Addr_GND,0x1d,0x07);//T4
  IS_IIC_WriteByte(Addr_GND,0x1e,0x07);
  IS_IIC_WriteByte(Addr_GND,0x1f,0x07);
  IS_IIC_WriteByte(Addr_GND,0x20,0x07);
  IS_IIC_WriteByte(Addr_GND,0x21,0x07);
  IS_IIC_WriteByte(Addr_GND,0x22,0x07);

  IS_IIC_WriteByte(Addr_GND,0x26,0x00);
  IS_IIC_WriteByte(Addr_GND,0x03,0x70);//One shot mode
}

```

Данный компонент на территории Российской Федерации

Вы можете приобрести в компании MosChip.

Для оперативного оформления запроса Вам необходимо перейти по данной ссылке:

<http://moschip.ru/get-element>

Вы можете разместить у нас заказ для любого Вашего проекта, будь то серийное производство или разработка единичного прибора.

В нашем ассортименте представлены ведущие мировые производители активных и пассивных электронных компонентов.

Нашей специализацией является поставка электронной компонентной базы двойного назначения, продукции таких производителей как XILINX, Intel (ex.ALTERA), Vicor, Microchip, Texas Instruments, Analog Devices, Mini-Circuits, Amphenol, Glenair.

Сотрудничество с глобальными дистрибьюторами электронных компонентов, предоставляет возможность заказывать и получать с международных складов практически любой перечень компонентов в оптимальные для Вас сроки.

На всех этапах разработки и производства наши партнеры могут получить квалифицированную поддержку опытных инженеров.

Система менеджмента качества компании отвечает требованиям в соответствии с ГОСТ Р ИСО 9001, ГОСТ РВ 0015-002 и ЭС РД 009

Офис по работе с юридическими лицами:

105318, г.Москва, ул.Щербаковская д.3, офис 1107, 1118, ДЦ «Щербаковский»

Телефон: +7 495 668-12-70 (многоканальный)

Факс: +7 495 668-12-70 (доб.304)

E-mail: info@moschip.ru

Skype отдела продаж:

moschip.ru

moschip.ru_4

moschip.ru_6

moschip.ru_9