

Product Overview

The QPQ1907 is a high-performance, high power Bulk Acoustic Wave (BAW) band-pass filter with extremely steep skirts, simultaneously exhibiting low loss in the Wi-Fi band and high near-in rejection in the 2.6GHz bands.

QPQ1907 is specifically designed to enable coexistence of Wi-Fi and LTE signals within the same device or in close proximity to one another..

Using common module packaging techniques to achieve the industry standard footprint while negating as many external passive placements to help end users ease of integration into their circuits

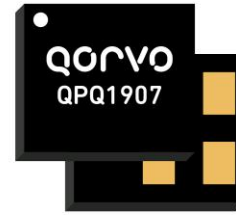

5 Pad 1.4 x 1.2 mm Laminate Package

Key Features

- 2447-2472 MHz
- Low loss in Wi-Fi band with extended upper corner for inclusion of Bluetooth
- High Rejection in LTE bands especially B7/B41
- Extended Temperature performance over -20 to +95 °C
- Self matched to Single Ended 50Ohm operation
- High power handling to +28dBm averaged Input Power

Functional Block Diagram

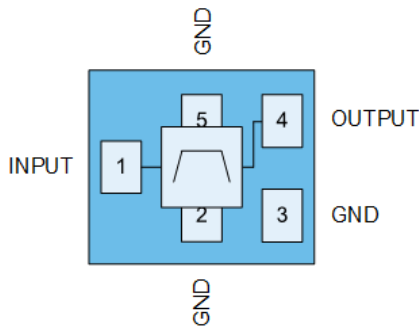

Top View

Applications

- Access Points
- Wireless Routers
- Residential Gateways
- Customer Premise Equipment
- Internet of Things

Ordering Information

Part Number	Description
QPQ1907SB	Sample bag with 5 pieces
QPQ1907SR	7" reel with 100 pieces
QPQ1907TR13-10K	13" reel with 10,000 pieces
QPQ1907EVB-01	Assembled Evaluation Board

Absolute Maximum Ratings

Parameter	Conditions	Rating
Operating Case Temperature	No damage	-40 to 105 °C
Storage Temperature		-40 to 125 °C

Exceeding any one or a combination of the Absolute Maximum Rating conditions may cause permanent damage to the device.

Minimum Lifetime Ratings

Parameter	Conditions	Rating
MTTF >1M hours, +95°C	802.11n MCS7 OFDM signal, 10dB PAR, applied to Pin 1	+28 dBm

Recommended Operating Conditions

Parameter	Min.	Typ.	Max.	Units
T _{OPERATING} *	-20		+95	°C

Electrical specifications are measured at specified test conditions. Specifications are not guaranteed over all recommended operating conditions. * T_{OPERATING} is temperature at the package ground

Electrical Specifications

Parameter (INPUT-OUTPUT) ⁽¹⁾	Conditions	Min.	Typ.	Max.	Units
Unless otherwise noted: Typ. T = 35°C					
Insertion Loss ⁽²⁾	f = 2402.5-2421.5 MHz (CH1)	-	1.5	2.2	dB
	f = 2407.5-2426.5 MHz (CH2)	-	1.3	1.6	dB
	f = 2412.5-2471.5 MHz (CH3-11)	-	0.8	1.3	dB
	f = 2457.5-2476.5 MHz (CH12)	-	1.0	1.5	dB
	f = 2462.5-2481.5 MHz (CH13)	-	1.4	2.2	dB
Amplitude Ripple	f = 2402.5-2421.5 MHz (CH1)	-	0.7	1.5	dB
	f = 2407.5-2426.5 MHz (CH2)	-	0.4	0.7	dB
	f = 2412.5-2471.5 MHz (CH3-11)	-	0.4	1.1	dB
	f = 2457.5-2476.5 MHz (CH12)	-	0.4	0.7	dB
	f = 2462.5-2481.5 MHz (CH13)	-	0.7	1.5	dB
INPUT VSWR	f = 2402.5-2481.5 MHz		1.5:1	1.8:1	dB
OUTPUT VSWR	f = 2402.5-2481.5 MHz		1.5:1	2.0:1	dB
Attenuation	f = 925–960 MHz	34	36	-	dB
	f = 1559–1606 MHz	34	46	-	dB
	f = 2110–2170 MHz	44	48	-	dB
	f = 2300–2370 MHz ⁽³⁾	38	45	-	dB
	f = 2500–2505 MHz ⁽³⁾⁽⁴⁾	30	39	-	dB
	f = 2500–2505 MHz ⁽³⁾⁽⁵⁾	10	39	-	dB
	f = 2505–2570 MHz ⁽³⁾⁽⁴⁾	43	62	-	dB
	f = 2505–2570 MHz ⁽³⁾⁽⁵⁾	40	62	-	dB
	f = 2570–2620 MHz ⁽³⁾	48	55	-	dB
f = 2620–2690 MHz ⁽³⁾	48	52	-	dB	

Parameter	Conditions	Min.	Typ.	Max.	Units
	$f = 4800\text{--}5000$ MHz	37	43	-	dB
	$f = 7200\text{--}7500$ MHz	7	21	-	dB

Notes:

- 1) All specifications are based on the QPQ1907 Applications Circuit
- 2) Data is the integrated value of the linear s-parameter over 19 MHz channel
- 3) Data is the integrated value of the linear s-parameter over 5 MHz range at the specified temperature
- 4) T = +25 to +95°C
- 5) T = -20 to +25°C
- 6) Pin 1 must be used for input. The large signal performance of this filter, such as power handling, may not be symmetric.

Performance Plots – QPQ1907EVB-01

Test conditions unless otherwise noted: Temp. = +25 °C

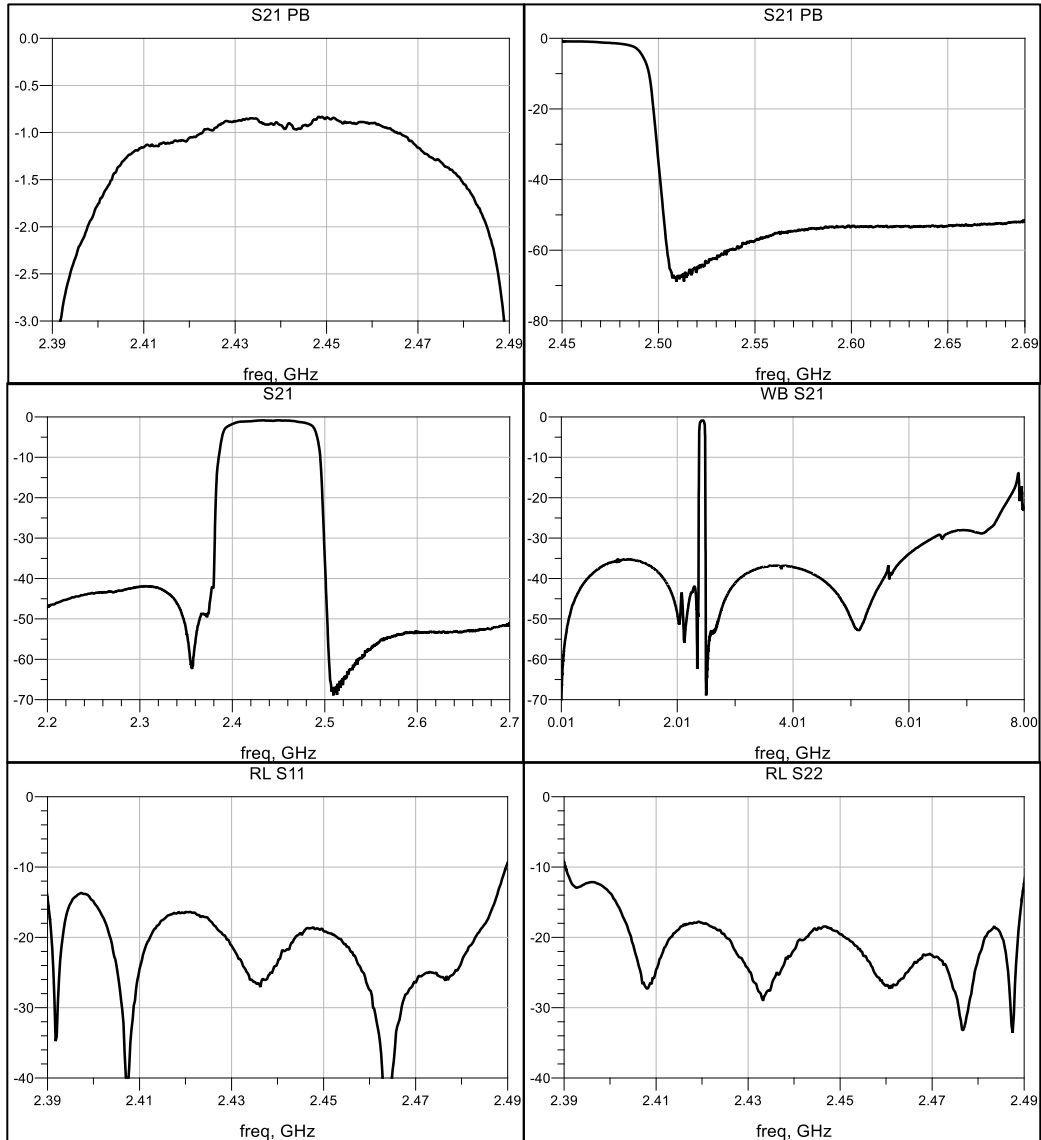

RL S11 Smith Chart

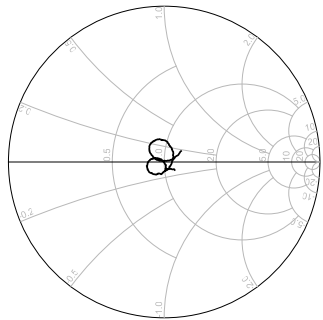

freq (2.402GHz to 2.482GHz)

RL S22 Smith Chart

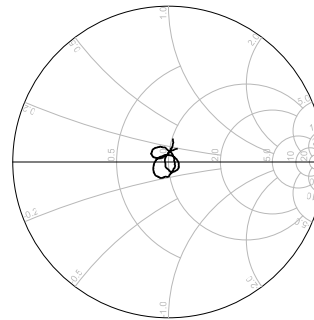

freq (2.402GHz to 2.482GHz)

Evaluation Board

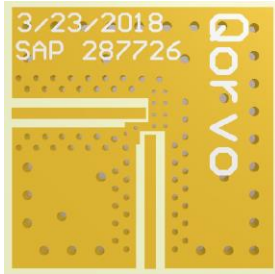

Bill of Material

Ref. Des.	Value	Description	Manuf.	Part number
-	-	Printed Circuit Board		
U1	-	Wi-Fi/LTE coexBoost BAW Filter	Qorvo	QPQ1907

Pin Configuration and Description

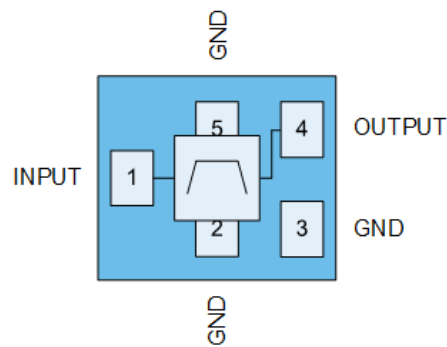

Top View

Pin Number	Label	Description
1	INPUT	RF input. Internally matched to 50 Ω .
2	GND	Ground connection.
3	GND	Ground connection.
4	OUTPUT	RF bi-directional port. Internally matched to 50 Ω
5	GND	Ground connection.

Mechanical Information

Dimensions and PCB Mounting Pattern

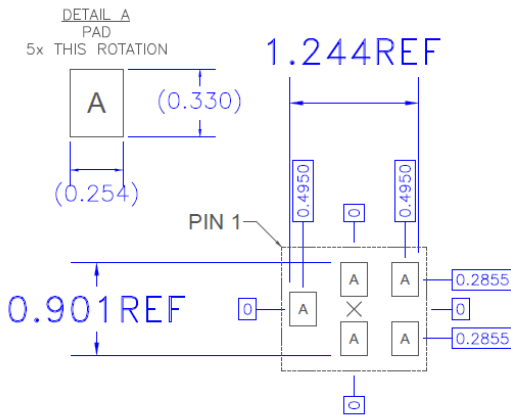
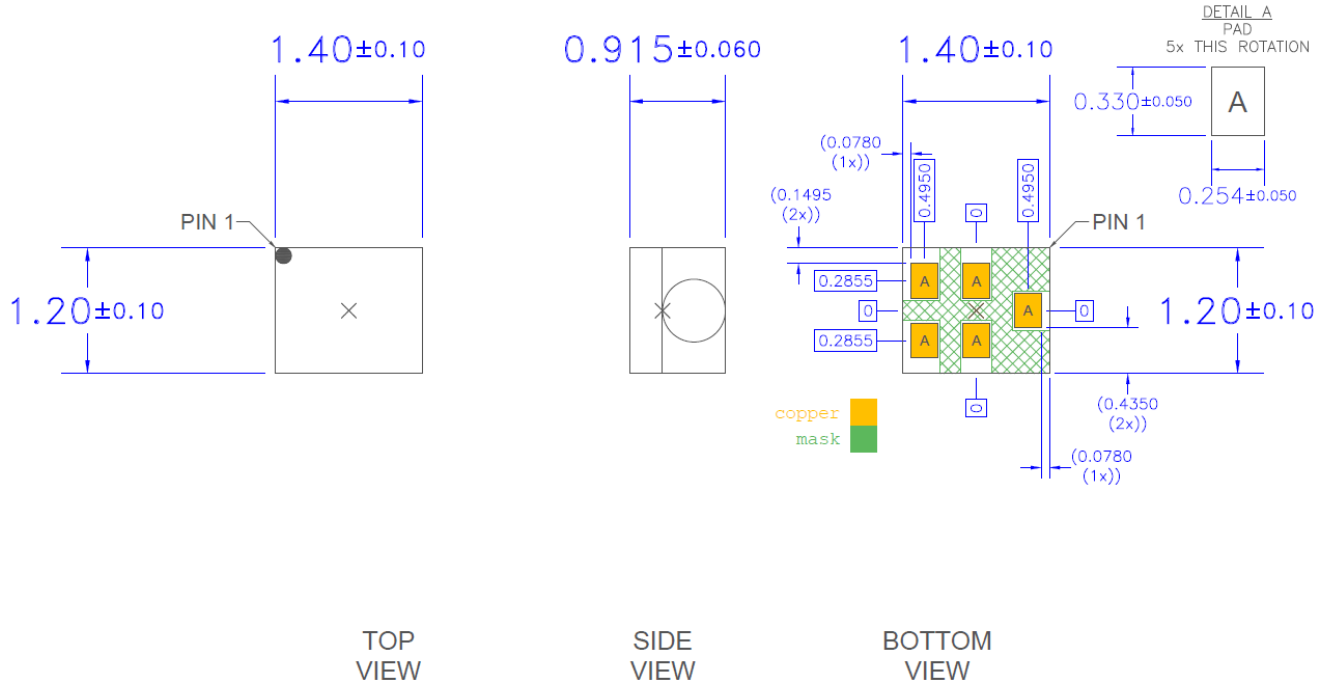

RECOMMENDED
LAND PATTERN

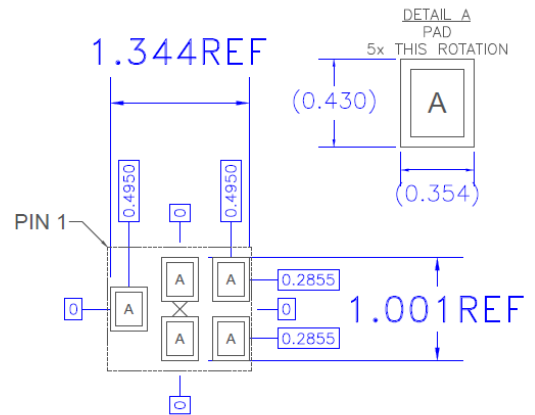

RECOMMENDED
LAND PATTERN MASK

Notes:

1. All dimensions are in millimeters. Angles are in degrees.
2. Dimension and tolerance formats conform to ASME Y14.4M-1994.
3. The terminal #1 identifier and terminal numbering conform to JESD 95-1 SPP-012.

Handling Precautions

Parameter	Rating	Standard
ESD – Human Body Model (HBM)	Class 1B (500V)	ANSI/ESD/JEDEC JS-001
ESD – Charged Device Model (CDM)	Class C3 (1000V)	ANSI/ESD/JEDEC JS-002
MSL – Moisture Sensitivity Level	Level 3	IPC/JEDEC J-STD-020



Caution!
ESD sensitive device

Solderability

Compatible with both lead-free (260 °C max. reflow temperature) and tin/lead (245 °C max. reflow temperature) soldering processes.

Package lead plating: Au (0.5-1.0µm) over Ni (2- 6µm)

RoHS Compliance

This part is compliant with the 2011/65/EU RoHS directive (Restrictions on the Use of Certain Hazardous Substances in Electrical and Electronic Equipment), as amended by Directive 2015/863/EU.

This product also has the following attributes:

- Lead free
- Halogen Free (Chlorine, Bromine)
- Antimony Free
- TBBP-A (C₁₅H₁₂Br₄O₂) Free
- SVHC Free



Contact Information

For the latest specifications, additional product information, worldwide sales and distribution locations:

Web: www.qorvo.com

Tel: 1-844-890-8163

Email: customer.support@qorvo.com

Important Notice

The information contained herein is believed to be reliable; however, Qorvo makes no warranties regarding the information contained herein and assumes no responsibility or liability whatsoever for the use of the information contained herein. All information contained herein is subject to change without notice. Customers should obtain and verify the latest relevant information before placing orders for Qorvo products. The information contained herein or any use of such information does not grant, explicitly or implicitly, to any party any patent rights, licenses, or any other intellectual property rights, whether with regard to such information itself or anything described by such information. **THIS INFORMATION DOES NOT CONSTITUTE A WARRANTY WITH RESPECT TO THE PRODUCTS DESCRIBED HEREIN, AND QORVO HEREBY DISCLAIMS ANY AND ALL WARRANTIES WITH RESPECT TO SUCH PRODUCTS WHETHER EXPRESS OR IMPLIED BY LAW, COURSE OF DEALING, COURSE OF PERFORMANCE, USAGE OF TRADE OR OTHERWISE, INCLUDING THE IMPLIED WARRANTIES OF MERCHANTABILITY AND FITNESS FOR A PARTICULAR PURPOSE.**

Without limiting the generality of the foregoing, Qorvo products are not warranted or authorized for use as critical components in medical, life-saving, or life-sustaining applications, or other applications where a failure would reasonably be expected to cause severe personal injury or death.

Copyright 2020 © Qorvo, Inc. | Qorvo is a registered trademark of Qorvo, Inc.

Данный компонент на территории Российской Федерации

Вы можете приобрести в компании MosChip.

Для оперативного оформления запроса Вам необходимо перейти по данной ссылке:

<http://moschip.ru/get-element>

Вы можете разместить у нас заказ для любого Вашего проекта, будь то серийное производство или разработка единичного прибора.

В нашем ассортименте представлены ведущие мировые производители активных и пассивных электронных компонентов.

Нашей специализацией является поставка электронной компонентной базы двойного назначения, продукции таких производителей как XILINX, Intel (ex.ALTERA), Vicor, Microchip, Texas Instruments, Analog Devices, Mini-Circuits, Amphenol, Glenair.

Сотрудничество с глобальными дистрибьюторами электронных компонентов, предоставляет возможность заказывать и получать с международных складов практически любой перечень компонентов в оптимальные для Вас сроки.

На всех этапах разработки и производства наши партнеры могут получить квалифицированную поддержку опытных инженеров.

Система менеджмента качества компании отвечает требованиям в соответствии с ГОСТ Р ИСО 9001, ГОСТ РВ 0015-002 и ЭС РД 009

Офис по работе с юридическими лицами:

105318, г.Москва, ул.Щербаковская д.3, офис 1107, 1118, ДЦ «Щербаковский»

Телефон: +7 495 668-12-70 (многоканальный)

Факс: +7 495 668-12-70 (доб.304)

E-mail: info@moschip.ru

Skype отдела продаж:

moschip.ru

moschip.ru_4

moschip.ru_6

moschip.ru_9