

NOTES:

1. MATERIALS:

- CONNECTOR HOUSING: HIGH TEMPERATURE THERMOPLASTIC GLASS FILLED, UL 94V-0
- EMI CAGE: NICKEL SILVER ALLOY
- EMI FINGERS: COPPER ALLOY
- TERMINALS: COPPER ALLOY
- LIGHT PIPES: HALOGEN FREE, CLEAR POLYCARBONATE

2. FINISHES:

- EMI FINGERS: 0.50µM MIN NICKEL
- CONTACT AREA: 0.76µM MIN GOLD OVER 2.54µM MIN NICKEL
- TAIL AREA: 0.76µM-1.52µM TIN OVER 2.54µM MIN NICKEL

3. PRODUCT SPECIFICATION: PS-76866-001

4. PACKAGING SPECIFICATION: PK-76866-002

- CONNECTORS WILL BE IN ONE BOX
- LIGHT PIPE ASSEMBLIES WILL BE IN ONE BOX
- BOTH BOXES WILL BE IN A MASTER CARTON

5. MATES WITH: MOLEX CABLE SERIES 111068

6. RECOMMENDED MOUNTING HARDWARE: REFER TO APPLICATION SPECIFICATION AS-76866-001

7. PLUG MODULE PCB LAYOUT REFER TO SD-76866-9900

|                                                                                                                                     |                          |                 |                                                      |       |                                   |                    |                                                                                                                                                   |                               |                        |  |
|-------------------------------------------------------------------------------------------------------------------------------------|--------------------------|-----------------|------------------------------------------------------|-------|-----------------------------------|--------------------|---------------------------------------------------------------------------------------------------------------------------------------------------|-------------------------------|------------------------|--|
| <b>REV'D NOTES</b><br>IEC NO: UCP2015-5060<br>DRWN:KCALLAGHAN 2015/06/01<br>CHKD:TMCCLELLAND 2015/06/03<br>APPR:TMCCLELL 2015/06/18 | DESCRIPTION<br>REV<br>D5 | QUALITY SYMBOLS | GENERAL TOLERANCES (UNLESS SPECIFIED)                |       | DIMENSION STYLE<br><b>MM ONLY</b> |                    | SCALE<br><b>2:1</b>                                                                                                                               | DESIGN UNITS<br><b>METRIC</b> | THIRD ANGLE PROJECTION |  |
|                                                                                                                                     |                          | ▽=0             | mm                                                   | INCH  | DRAWN BY<br>KLANG                 | DATE<br>2009/06/04 | <b>IPASS PLUS HD<br/>         1X1 EXT REC &amp; CAGE<br/>         LIGHT PIPE</b><br><b>molex</b><br>DOCUMENT NO. SD-76866-021<br>SHEET NO. 1 OF 4 |                               |                        |  |
|                                                                                                                                     |                          | ▽=0             | 4 PLACES ± ---                                       | ± --- | CHECKED BY<br>TMCCLELLAND         | DATE<br>2013/10/16 |                                                                                                                                                   |                               |                        |  |
|                                                                                                                                     |                          | ▽=0             | 3 PLACES ± ---                                       | ± --- | APPROVED BY<br>MBANAKIS           | DATE<br>2010/01/14 |                                                                                                                                                   |                               |                        |  |
| ▽=0                                                                                                                                 | 2 PLACES ± 0.13          | ± ---           | MATERIAL NO.<br><b>76866-0121</b>                    |       |                                   |                    |                                                                                                                                                   |                               |                        |  |
|                                                                                                                                     |                          |                 | ANGULAR ±1/2°                                        |       | SIZE<br>C                         |                    | THIS DRAWING CONTAINS INFORMATION THAT IS PROPRIETARY TO MOLEX INCORPORATED AND SHOULD NOT BE USED WITHOUT WRITTEN PERMISSION                     |                               |                        |  |
|                                                                                                                                     |                          |                 | DRAFT WHERE APPLICABLE MUST REMAIN WITHIN DIMENSIONS |       |                                   |                    |                                                                                                                                                   |                               |                        |  |

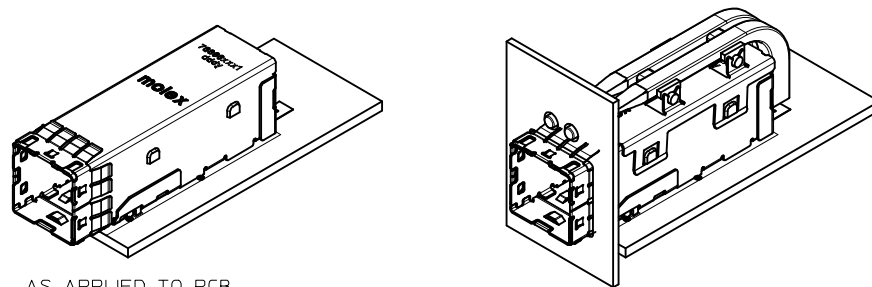

AS APPLIED TO PCB

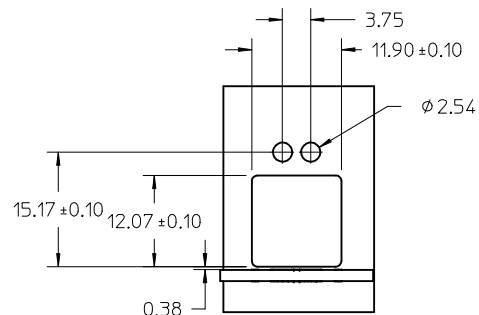
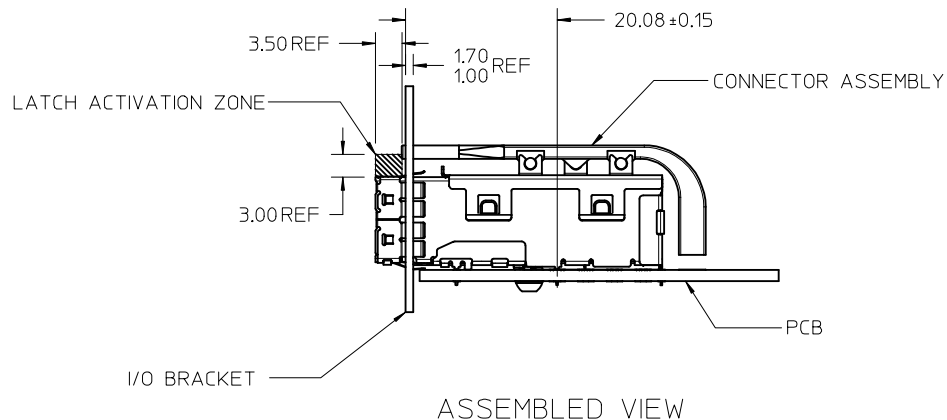

I/O BRACKET CUT OUT  
(BRACKET NOT SUPPLIED)

|                                                                                                                                     |                 |                                       |                                                      |                                   |                                                                                                                               |                                                                    |                               |                        |  |
|-------------------------------------------------------------------------------------------------------------------------------------|-----------------|---------------------------------------|------------------------------------------------------|-----------------------------------|-------------------------------------------------------------------------------------------------------------------------------|--------------------------------------------------------------------|-------------------------------|------------------------|--|
| <b>SEE SHEET 1</b><br>EC NO: UCP2015-5060<br>DRINKCALLAGHAN 2015/06/01<br>CHKD: TMCCLELLAND 2015/06/03<br>APPR: TMCCLELL 2015/06/18 | QUALITY SYMBOLS | GENERAL TOLERANCES (UNLESS SPECIFIED) |                                                      | DIMENSION STYLE<br><b>MM ONLY</b> |                                                                                                                               | SCALE<br><b>2:1</b>                                                | DESIGN UNITS<br><b>METRIC</b> | THIRD ANGLE PROJECTION |  |
|                                                                                                                                     | ▽=0             | mm                                    | INCH                                                 | DRAWN BY<br>KLANG                 | DATE<br>2009/06/04                                                                                                            | <b>IPASS PLUS HD<br/>1X1 EXT REC &amp; CAGE<br/>LIGHT PIPE</b><br> |                               |                        |  |
|                                                                                                                                     | ▽=0             | 4 PLACES ± ---                        | ± ---                                                | CHECKED BY<br>TMCCLELLAND         | DATE<br>2013/10/16                                                                                                            |                                                                    |                               |                        |  |
|                                                                                                                                     | ▽=0             | 3 PLACES ± ---                        | ± ---                                                | APPROVED BY<br>MBANAKIS           | DATE<br>2010/01/14                                                                                                            | MATERIAL NO.                                                       | DOCUMENT NO.                  | SHEET NO.              |  |
| ▽=0                                                                                                                                 | 2 PLACES ± 0.13 | ± ---                                 | <b>SEE SHEET 1</b>                                   |                                   | <b>SD-76866-021</b>                                                                                                           |                                                                    | <b>2 OF 4</b>                 |                        |  |
|                                                                                                                                     | 1 PLACE ± 0.25  | ± ---                                 | DRAFT WHERE APPLICABLE MUST REMAIN WITHIN DIMENSIONS |                                   | THIS DRAWING CONTAINS INFORMATION THAT IS PROPRIETARY TO MOLEX INCORPORATED AND SHOULD NOT BE USED WITHOUT WRITTEN PERMISSION |                                                                    |                               |                        |  |
|                                                                                                                                     | 0 PLACE ±       | ±                                     |                                                      |                                   |                                                                                                                               |                                                                    |                               |                        |  |

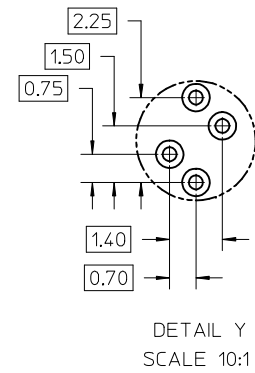
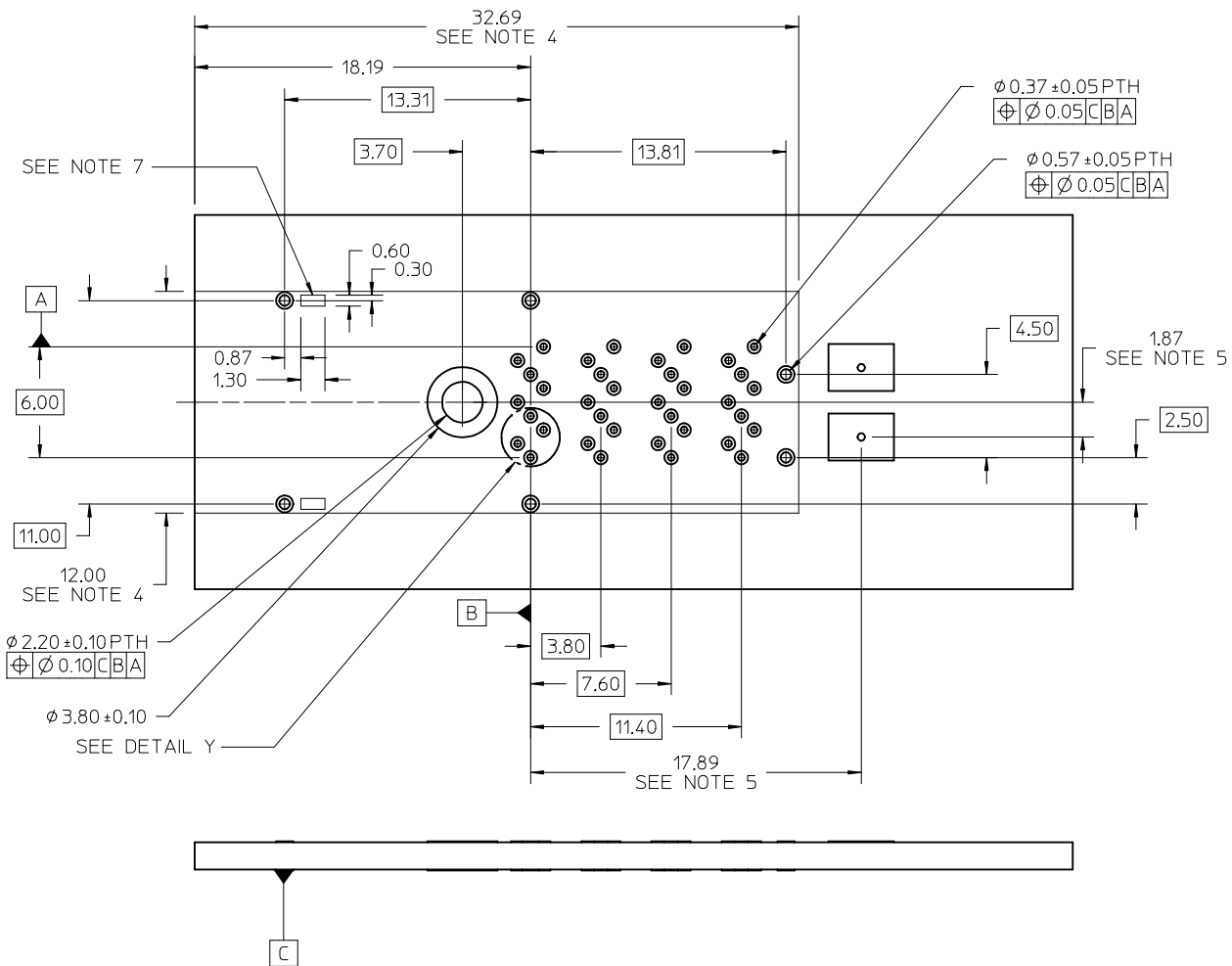

NOTES:

1. RECOMMENDED DRILL SIZE AND ANNULAR RING FOR A 0.37 $\phi$  FINISHED PTH - REFER TO APPLICATION SPECIFICATION AS-76866-001
2. MINIMUM RECOMMENDED SPACING: 14.00MM
3. MINIMUM PCB THICKNESS: 1.57MM
4. CONNECTOR KEEP OUT AREA
5. LOCATION OF LED CENTER LINE
6. RECOMMENDED DRILL SIZE AND ANNULAR RING FOR A 0.57 $\phi$  FINISHED PTH - REFER TO APPLICATION SPECIFICATION AS-76866-001
7. CAGE STAND OFF AREA, NO TRACES ON SURFACE OF PCB IN THESE AREAS

RECOMMENDED FOOTPRINT

|                                                                                                                             |                          |                 |                                       |               |                            |                                                                                                                               |                                                                                                                                          |                        |                        |  |
|-----------------------------------------------------------------------------------------------------------------------------|--------------------------|-----------------|---------------------------------------|---------------|----------------------------|-------------------------------------------------------------------------------------------------------------------------------|------------------------------------------------------------------------------------------------------------------------------------------|------------------------|------------------------|--|
| SEE SHEET 1<br>EC NO: UCP2015-5060<br>DRWN: KALLAGHAN 2015/06/01<br>CHKD: TMCLELLAND 2015/06/03<br>APPR: TMCLELL 2015/06/18 | DESCRIPTION<br>REV<br>D5 | QUALITY SYMBOLS | GENERAL TOLERANCES (UNLESS SPECIFIED) |               | DIMENSION STYLE<br>MM ONLY |                                                                                                                               | SCALE<br>5:1                                                                                                                             | DESIGN UNITS<br>METRIC | THIRD ANGLE PROJECTION |  |
|                                                                                                                             |                          | ▽=0             | mm                                    | INCH          | DRAWN BY<br>KLANG          | DATE<br>2009/06/04                                                                                                            | TITLE<br><b>IPASS PLUS HD<br/>1X1 EXT REC &amp; CAGE<br/>LIGHT PIPE</b><br><b>molex</b><br>DOCUMENT NO. SD-76866-021<br>SHEET NO. 3 OF 4 |                        |                        |  |
|                                                                                                                             |                          | ▽=0             | 4 PLACES ± ---                        | ± ---         | CHECKED BY<br>TMCLELLAND   | DATE<br>2013/10/16                                                                                                            |                                                                                                                                          |                        |                        |  |
|                                                                                                                             |                          | ▽=0             | 3 PLACES ± ---                        | ± ---         | APPROVED BY<br>MBANAKIS    | DATE<br>2010/01/14                                                                                                            |                                                                                                                                          |                        |                        |  |
| ▽=0                                                                                                                         | 2 PLACES ± 0.13          | ± ---           | MATERIAL NO.<br><b>SEE SHEET 1</b>    |               |                            |                                                                                                                               |                                                                                                                                          |                        |                        |  |
|                                                                                                                             |                          | 0 PLACE ±       | ±                                     | ANGULAR ±1/2° |                            | DRAFT WHERE APPLICABLE MUST REMAIN WITHIN DIMENSIONS                                                                          |                                                                                                                                          |                        |                        |  |
|                                                                                                                             |                          |                 |                                       | SIZE<br>C     |                            | THIS DRAWING CONTAINS INFORMATION THAT IS PROPRIETARY TO MOLEX INCORPORATED AND SHOULD NOT BE USED WITHOUT WRITTEN PERMISSION |                                                                                                                                          |                        |                        |  |

# RECOMMENDED TOOLING KEEP OUT AREAS

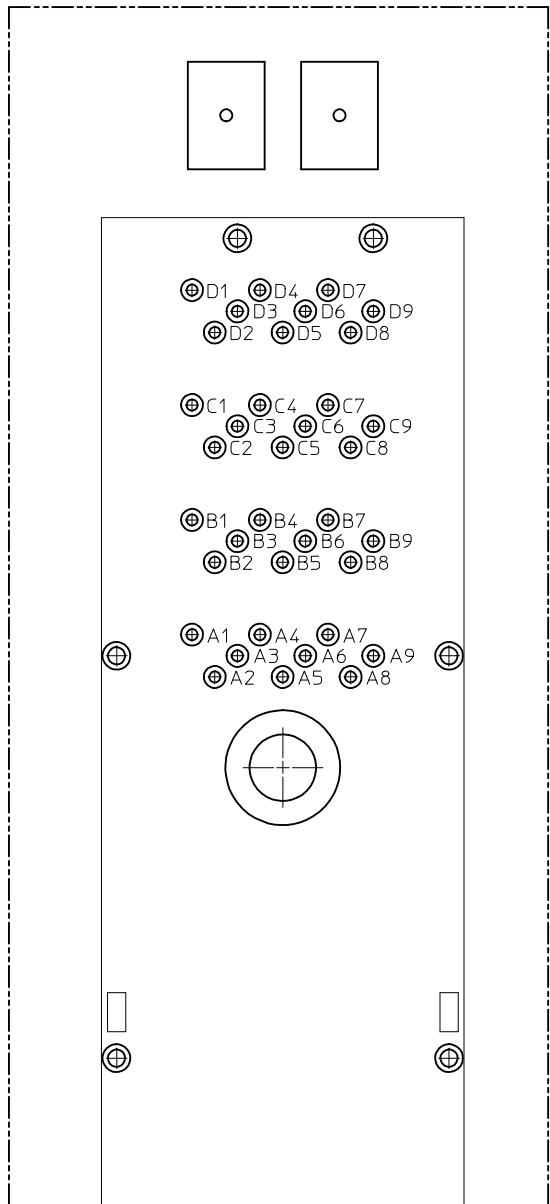

CIRCUIT IDENTIFICATION

Partial1  
SCALE 8:1

RECOMMENDED INSERTION TOOL  
KEEP OUT AREA  
NO COMPONENTS IN THIS AREA  
MORE THAN 7.50 mm TALL

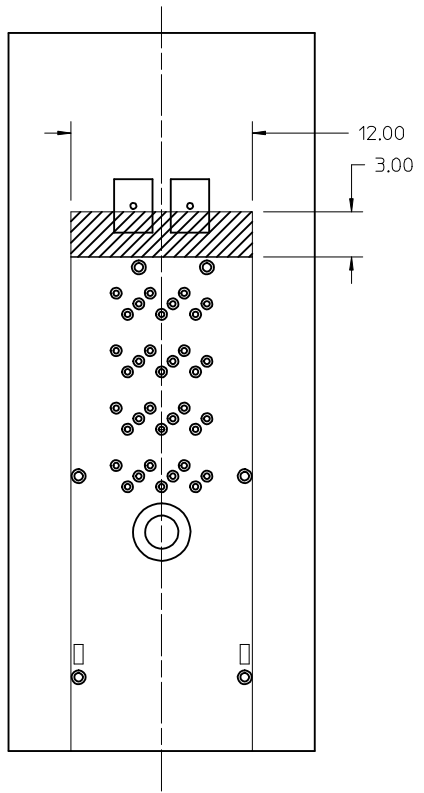
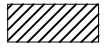

RECOMMENDED EXTRACTION TOOL  
KEEP OUT AREA  
NO COMPONENTS IN THESE AREAS  
NO COMPONENTS IN THIS AREA  
MORE THAN 5.00 mm TALL

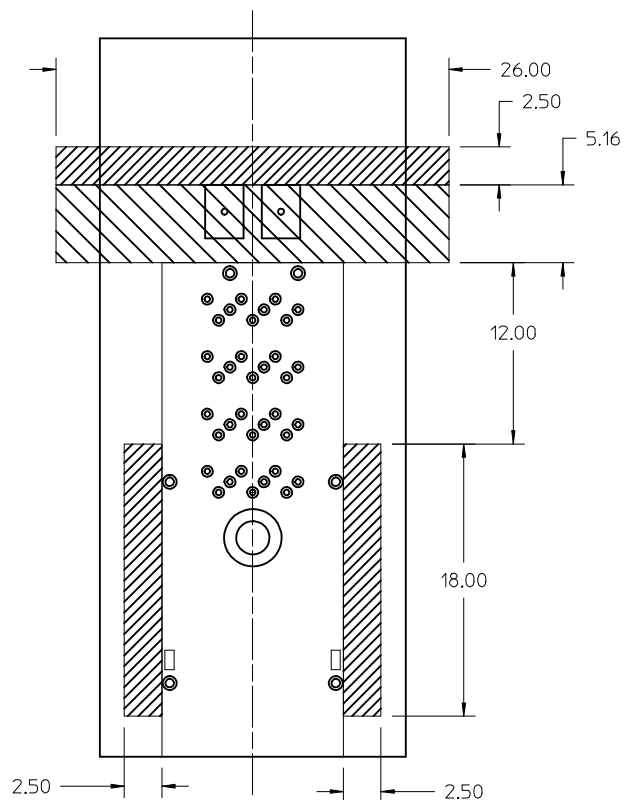
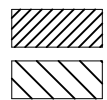

| SEE SHEET 1<br>EC NO: UCP2015-5060<br>DRINKCALLAGHAN 2015/06/01<br>CHKD:TMCCLELLAND 2015/06/03<br>APPR:TMCCLELL 2015/06/18<br>REV D5 | QUALITY SYMBOLS<br>∇=0<br>∇=0<br>∇=0 | GENERAL TOLERANCES (UNLESS SPECIFIED)<br><table border="1"> <tr> <th></th> <th>mm</th> <th>INCH</th> </tr> <tr> <td>4 PLACES</td> <td>± ---</td> <td>± ---</td> </tr> <tr> <td>3 PLACES</td> <td>± ---</td> <td>± ---</td> </tr> <tr> <td>2 PLACES</td> <td>± 0.13</td> <td>± ---</td> </tr> <tr> <td>1 PLACE</td> <td>± 0.25</td> <td>± ---</td> </tr> <tr> <td>0 PLACE</td> <td>±</td> <td>±</td> </tr> </table> |             | mm                                                                                                                            | INCH | 4 PLACES | ± --- | ± --- | 3 PLACES | ± --- | ± --- | 2 PLACES | ± 0.13 | ± --- | 1 PLACE | ± 0.25 | ± --- | 0 PLACE | ± | ± | DIMENSION STYLE<br><b>MM ONLY</b><br>DRAWN BY DATE<br>KLANG 2009/06/04<br>CHECKED BY DATE<br>TMCCLELLAND 2013/10/16<br>APPROVED BY DATE<br>MBANAKIS 2010/01/14<br>MATERIAL NO. | SCALE<br><b>4:1</b><br>DESIGN UNITS<br>METRIC<br>THIRD ANGLE PROJECTION | TITLE<br><b>IPASS PLUS HD<br/>1X1 EXT REC &amp; CAGE<br/>LIGHT PIPE</b><br><b>molex</b><br>DOCUMENT NO.<br><b>SD-76866-021</b><br>SHEET NO.<br>4 OF 4 |
|--------------------------------------------------------------------------------------------------------------------------------------|--------------------------------------|--------------------------------------------------------------------------------------------------------------------------------------------------------------------------------------------------------------------------------------------------------------------------------------------------------------------------------------------------------------------------------------------------------------------|-------------|-------------------------------------------------------------------------------------------------------------------------------|------|----------|-------|-------|----------|-------|-------|----------|--------|-------|---------|--------|-------|---------|---|---|--------------------------------------------------------------------------------------------------------------------------------------------------------------------------------|-------------------------------------------------------------------------|-------------------------------------------------------------------------------------------------------------------------------------------------------|
|                                                                                                                                      |                                      | mm                                                                                                                                                                                                                                                                                                                                                                                                                 | INCH        |                                                                                                                               |      |          |       |       |          |       |       |          |        |       |         |        |       |         |   |   |                                                                                                                                                                                |                                                                         |                                                                                                                                                       |
|                                                                                                                                      | 4 PLACES                             | ± ---                                                                                                                                                                                                                                                                                                                                                                                                              | ± ---       |                                                                                                                               |      |          |       |       |          |       |       |          |        |       |         |        |       |         |   |   |                                                                                                                                                                                |                                                                         |                                                                                                                                                       |
|                                                                                                                                      | 3 PLACES                             | ± ---                                                                                                                                                                                                                                                                                                                                                                                                              | ± ---       |                                                                                                                               |      |          |       |       |          |       |       |          |        |       |         |        |       |         |   |   |                                                                                                                                                                                |                                                                         |                                                                                                                                                       |
|                                                                                                                                      | 2 PLACES                             | ± 0.13                                                                                                                                                                                                                                                                                                                                                                                                             | ± ---       |                                                                                                                               |      |          |       |       |          |       |       |          |        |       |         |        |       |         |   |   |                                                                                                                                                                                |                                                                         |                                                                                                                                                       |
| 1 PLACE                                                                                                                              | ± 0.25                               | ± ---                                                                                                                                                                                                                                                                                                                                                                                                              |             |                                                                                                                               |      |          |       |       |          |       |       |          |        |       |         |        |       |         |   |   |                                                                                                                                                                                |                                                                         |                                                                                                                                                       |
| 0 PLACE                                                                                                                              | ±                                    | ±                                                                                                                                                                                                                                                                                                                                                                                                                  |             |                                                                                                                               |      |          |       |       |          |       |       |          |        |       |         |        |       |         |   |   |                                                                                                                                                                                |                                                                         |                                                                                                                                                       |
| DRAFT WHERE APPLICABLE MUST REMAIN WITHIN DIMENSIONS                                                                                 |                                      | ANGULAR ±1/2°                                                                                                                                                                                                                                                                                                                                                                                                      | SEE SHEET 1 | THIS DRAWING CONTAINS INFORMATION THAT IS PROPRIETARY TO MOLEX INCORPORATED AND SHOULD NOT BE USED WITHOUT WRITTEN PERMISSION |      |          |       |       |          |       |       |          |        |       |         |        |       |         |   |   |                                                                                                                                                                                |                                                                         |                                                                                                                                                       |

## Данный компонент на территории Российской Федерации

### Вы можете приобрести в компании MosChip.

Для оперативного оформления запроса Вам необходимо перейти по данной ссылке:

<http://moschip.ru/get-element>

Вы можете разместить у нас заказ для любого Вашего проекта, будь то серийное производство или разработка единичного прибора.

В нашем ассортименте представлены ведущие мировые производители активных и пассивных электронных компонентов.

Нашей специализацией является поставка электронной компонентной базы двойного назначения, продукции таких производителей как XILINX, Intel (ex.ALTERA), Vicor, Microchip, Texas Instruments, Analog Devices, Mini-Circuits, Amphenol, Glenair.

Сотрудничество с глобальными дистрибьюторами электронных компонентов, предоставляет возможность заказывать и получать с международных складов практически любой перечень компонентов в оптимальные для Вас сроки.

На всех этапах разработки и производства наши партнеры могут получить квалифицированную поддержку опытных инженеров.

Система менеджмента качества компании отвечает требованиям в соответствии с ГОСТ Р ИСО 9001, ГОСТ РВ 0015-002 и ЭС РД 009

### Офис по работе с юридическими лицами:

105318, г.Москва, ул.Щербаковская д.3, офис 1107, 1118, ДЦ «Щербаковский»

Телефон: +7 495 668-12-70 (многоканальный)

Факс: +7 495 668-12-70 (доб.304)

E-mail: [info@moschip.ru](mailto:info@moschip.ru)

Skype отдела продаж:

moschip.ru

moschip.ru\_4

moschip.ru\_6

moschip.ru\_9