

Discrete Wire-to-Board; Poke-Home



Series 9276



The new 9276 series connector provides a quick and reliable wire-to-board termination in a sleek 2.5mm pitch SMT package for a broad range of industrial and commercial markets. With almost every product on the market today having to deal with a small number of discrete wires to connect components to a board, the 9276 series connectors meets this challenge by simply stripping the wire and inserting them into the connector. This makes the connector very termination friendly within the factory as well as in the field by electrical installers. Developed for harsh industrial and Solid State Lighting (SSL) applications, the connector was designed with a high spring force Beryllium Copper upper spring contact to accept a wide range (18-24 AWG solid or stranded) of wire to meet multiple applications with a single connector. By incorporating a dual-contact design we were able to maximize current rating (6 Amps) and minimize PCB space. For example, the 4p connector has a footprint of 90 sq-mm while competing products are 160 sq-mm. The dual-contact design also provides two solder points for each wire eliminating the need for external anchor tabs. AVX provides a small insertion / extraction tool which will allow the wires to easily be replaced up to 5 times.

APPLICATIONS

- Connecting discrete wire components directly to the PCB
- Bringing power and signals onto a PCB
- Daisy chaining PCB's together to create a continuous string of boards
- Application notes; refer to 201-01-127

FEATURES AND BENEFITS

- Simple strip, insert and removal design
- SMT RoHS termination to the PCB with minimal footprint
- Accepts 18-24AWG Solid and Stranded wires
- Expanded size offering to maximize application potential; 1, 2, 3, 4, 6 & 8 positions
- High spring force top contact provides a lance type retention to capture and retain the wire
- Available in standard white and optional black color

ELECTRICAL

- Current Rating: 6 Amps / Contact
- Voltage Rating: 250v AC

ENVIRONMENTAL

- Operating Temperature: -40°C to +125°C

MECHANICAL

- Insulator Material: Glass-Filled Nylon 46; UL94V0
- Contact Material: Beryllium Copper / Phosphor Bronze
- Plating: Tin over Nickel
- Replacibility: 5 Cycles

HOW TO ORDER

00	9276	00X	0	21	X	06
Wire to Board Connector	Series	Number of Ways	Horizontal Mounting	Wire Size	Insulator Color	Plating Option

Code	No of Ways	Details
001	1	Page 2
002	2	Page 3
003	3	Page 4
004	4	Page 5
006	6	Page 6
008	8	Page 7

Code	Wire Gauge	Max Conductor	Max Insulation
21	18 - 24 AWG	1.20mm Diameter	2.10mm Diameter

Code	Color	Application
0	Black	Industrial
1	White	Lighting

Tin all over

Discrete Wire-to-Board; Poke-Home



Series 9276

1 WAY WIRE TO BOARD CONNECTOR

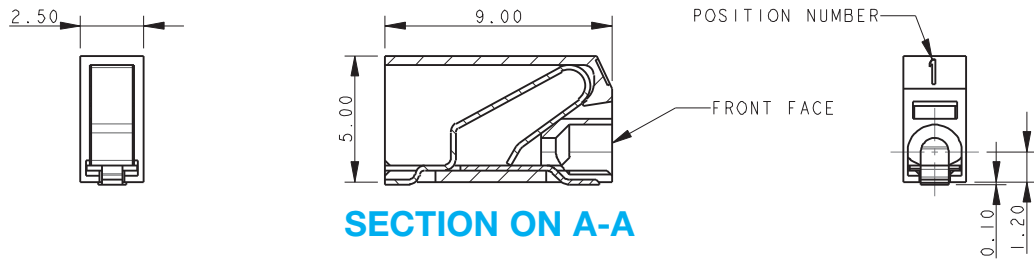

SECTION ON A-A

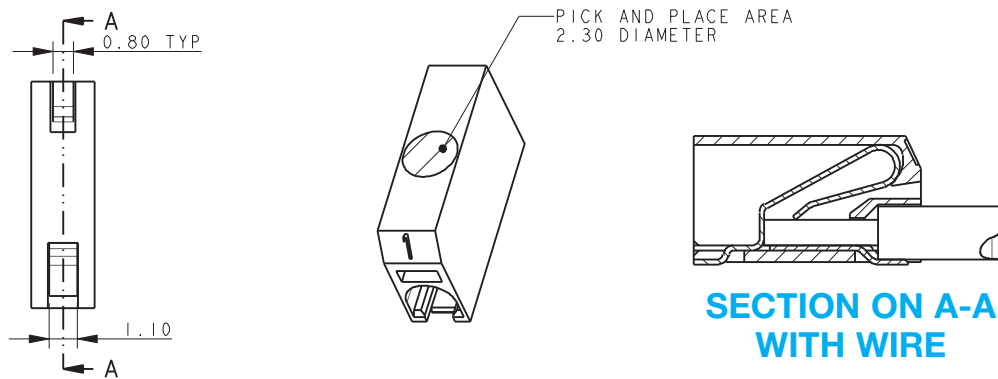

SECTION ON A-A WITH WIRE

NOTES:

1. 9276 ONE WAY CONNECTOR, REFER TO ELCO SPECIFICATION 201-01-125 AND APPLICATION NOTES 201-01-127 FOR FURTHER DETAILS
2. INSULATOR MATERIAL: NYLON 46, GLASS FILLED, UL94 V-0, COLOR REFER TO PAGE 1
3. CONTACT MATERIAL: COPPER ALLOY, 0.20MM THICK, TIN PLATED.
4. OUTLINE OF CONNECTOR.
5. WIRE ASSEMBLY / EXTRACTION, REFER TO PAGE 8.
6. FRONT FACE OF CONNECTOR CAN BE IN LINE WITH EDGE OF PCB.
7. PACKING TAPE AND REEL, QUANTITY 1000 PER REEL.

PACKING DETAILS

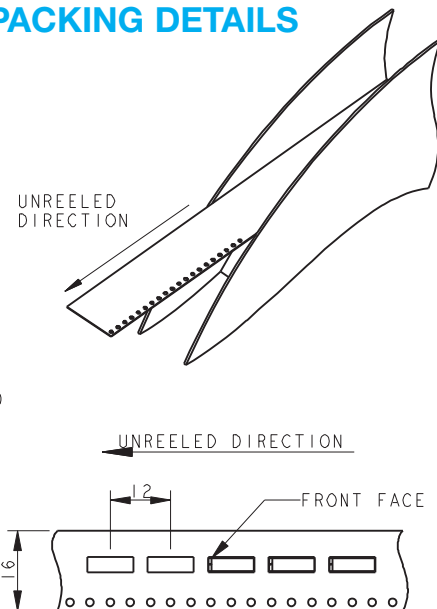

1 WAY PCB BOARD LAYOUT

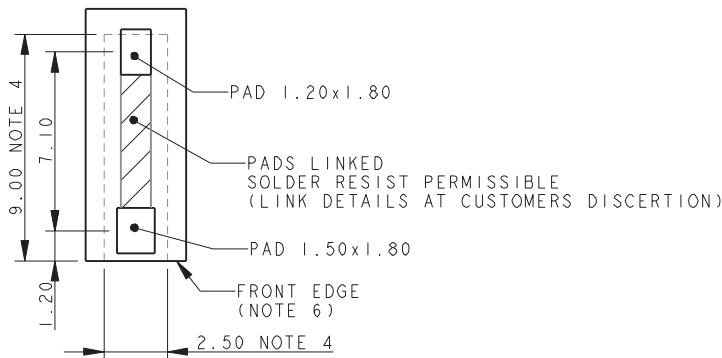

2 WAY WIRE TO BOARD CONNECTOR

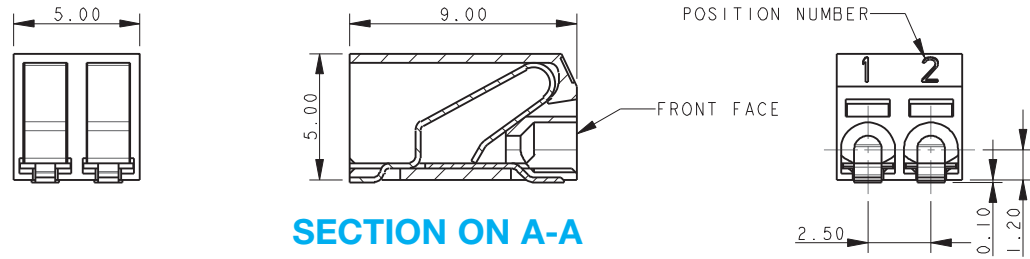

SECTION ON A-A

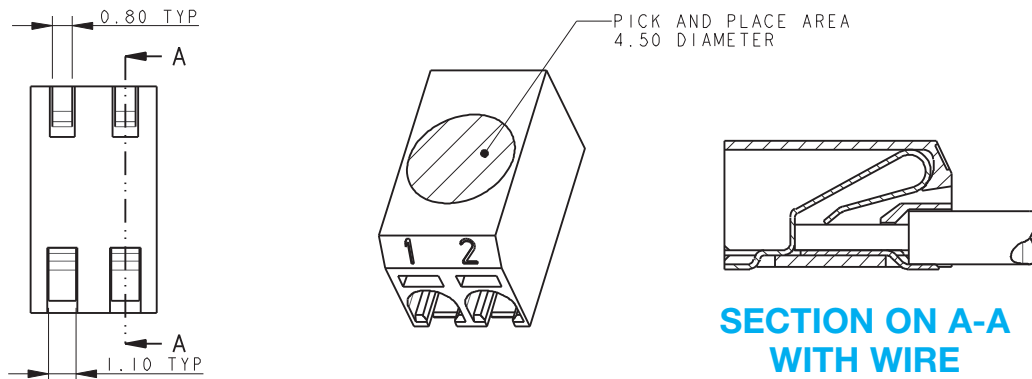

SECTION ON A-A WITH WIRE

NOTES:

1. 9276 TWO WAY CONNECTOR, REFER TO ELCO SPECIFICATION 201-01-125 AND APPLICATION NOTES 201-01-127 FOR FURTHER DETAILS
2. INSULATOR MATERIAL: NYLON 46, GLASS FILLED, UL94 V-0, COLOR REFER TO PAGE 1
3. CONTACT MATERIAL: COPPER ALLOY, 0.20MM THICK, TIN PLATED.
4. OUTLINE OF CONNECTOR.
5. WIRE ASSEMBLY / EXTRACTION, REFER TO PAGE 8.
6. FRONT FACE OF CONNECTOR CAN BE IN LINE WITH EDGE OF PCB.
7. PACKING TAPE AND REEL, QUANTITY 1000 PER REEL.

PACKING DETAILS

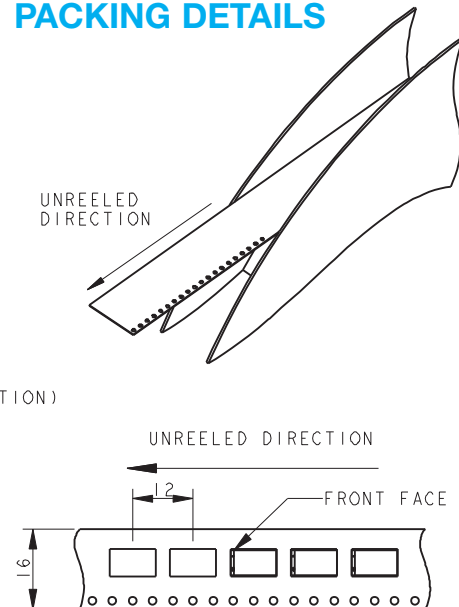

2 WAY PCB BOARD LAYOUT

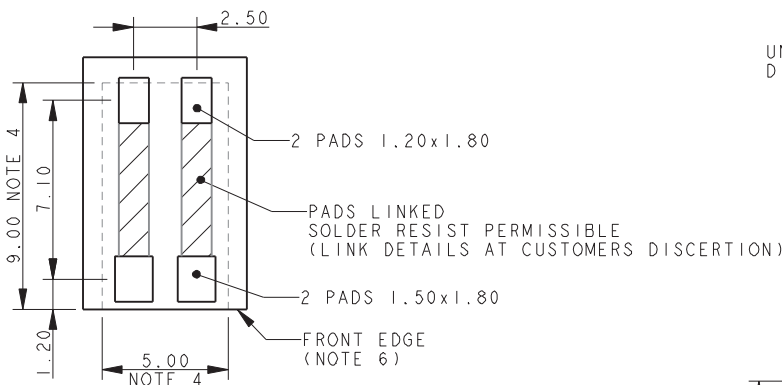

3 WAY WIRE TO BOARD CONNECTOR

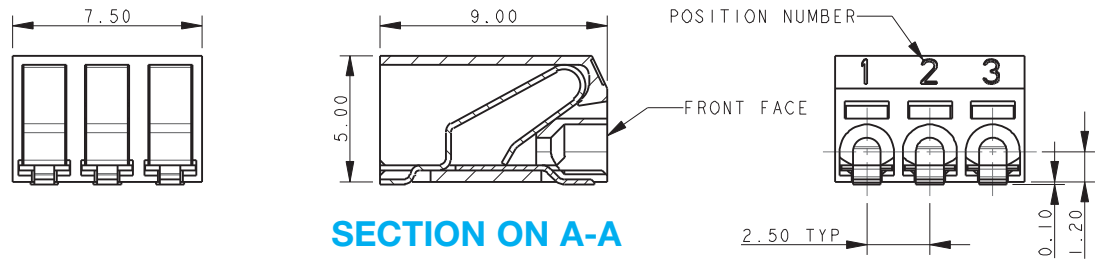

SECTION ON A-A

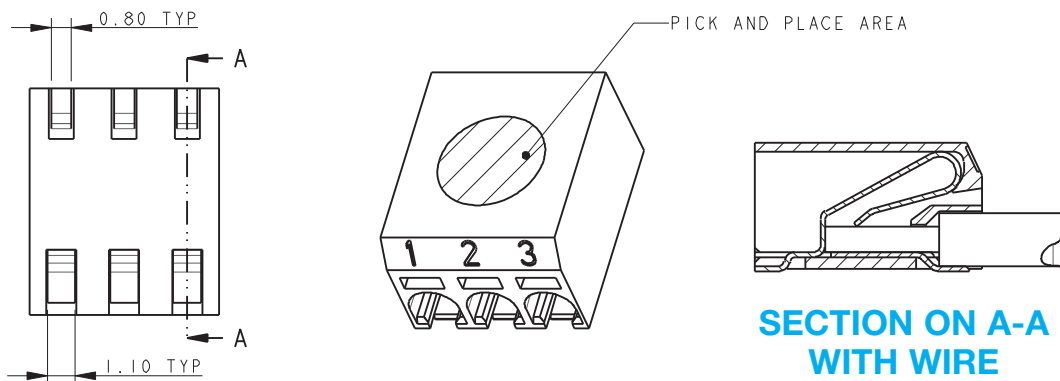

NOTES:

1. 9276 THREE WAY CONNECTOR, REFER TO ELCO SPECIFICATION 201-01-125 AND APPLICATION NOTES 201-01-127 FOR FURTHER DETAILS
2. INSULATOR MATERIAL: NYLON 46, GLASS FILLED, UL94 V-0, COLOR REFER TO PAGE 1
3. CONTACT MATERIAL: COPPER ALLOY, 0.20MM THICK, TIN PLATED.
4. OUTLINE OF CONNECTOR.
5. WIRE ASSEMBLY / EXTRACTION, REFER TO PAGE 8.
6. FRONT FACE OF CONNECTOR CAN BE IN LINE WITH EDGE OF PCB.
7. PACKING TAPE AND REEL, QUANTITY 1000 PER REEL.

PACKING DETAILS

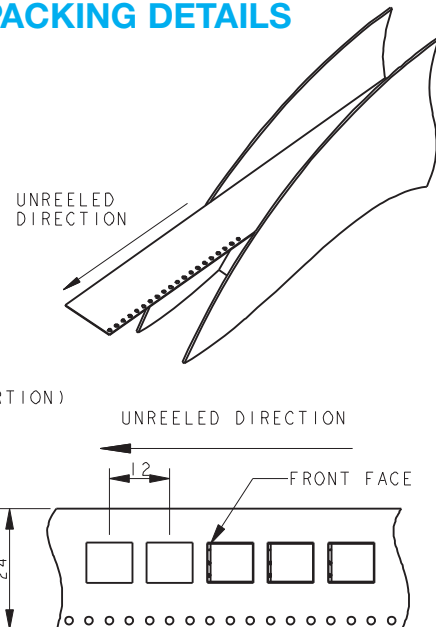

3 WAY PCB BOARD LAYOUT

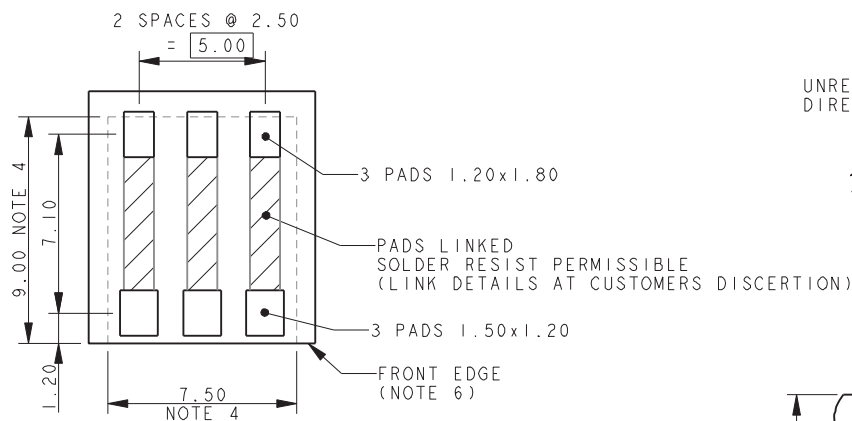

Discrete Wire-to-Board; Poke-Home



Series 9276

4 WAY WIRE TO BOARD CONNECTOR

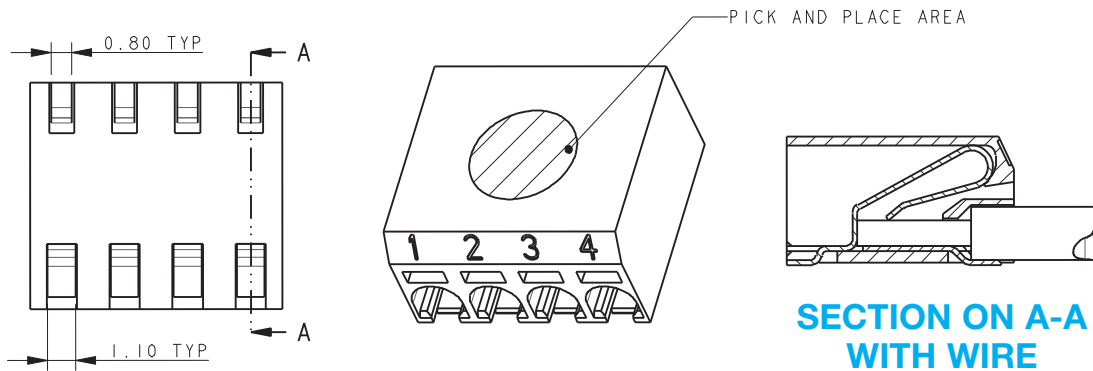
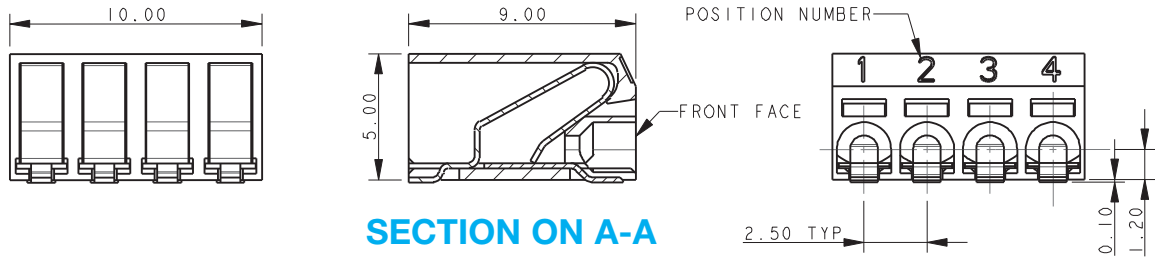

NOTES:

1. 9276 FOUR WAY CONNECTOR, REFER TO ELCO SPECIFICATION 201-01-125 AND APPLICATION NOTES 201-01-127 FOR FURTHER DETAILS
2. INSULATOR MATERIAL: NYLON 46, GLASS FILLED, UL94 V-0, COLOR REFER TO PAGE 1
3. CONTACT MATERIAL: COPPER ALLOY, 0.20MM THICK, TIN PLATED.
4. OUTLINE OF CONNECTOR.
5. WIRE ASSEMBLY / EXTRACTION, REFER TO PAGE 8.
6. FRONT FACE OF CONNECTOR CAN BE IN LINE WITH EDGE OF PCB.
7. PACKING TAPE AND REEL, QUANTITY 1000 PER REEL.

PACKING DETAILS

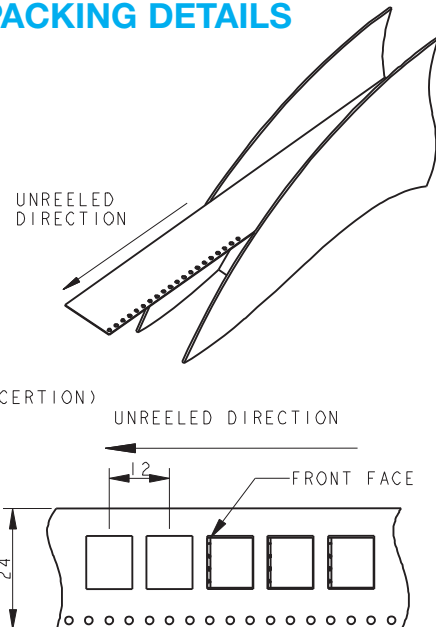

4 WAY PCB BOARD LAYOUT

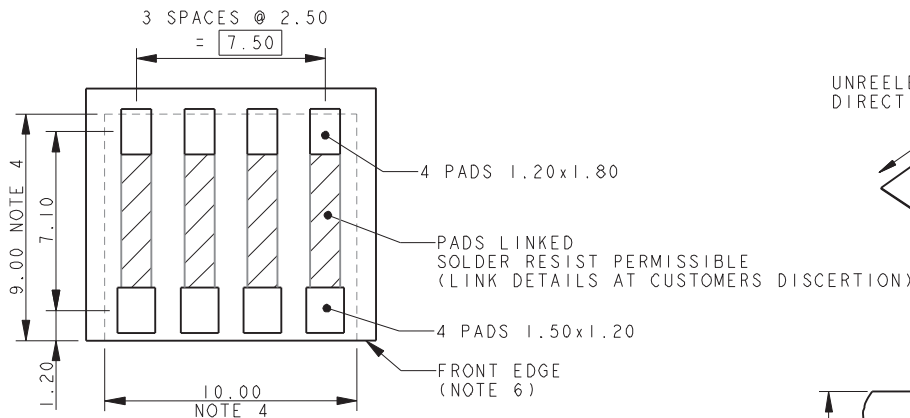

6 WAY WIRE TO BOARD CONNECTOR

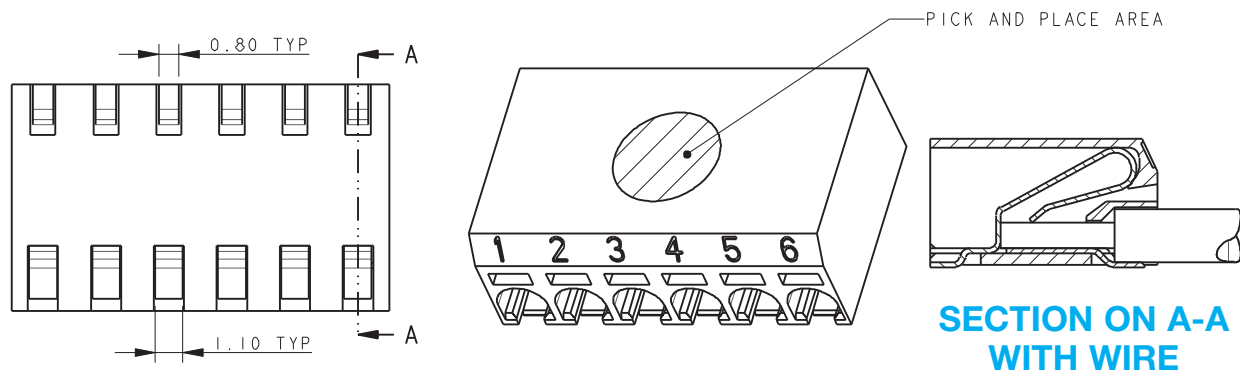
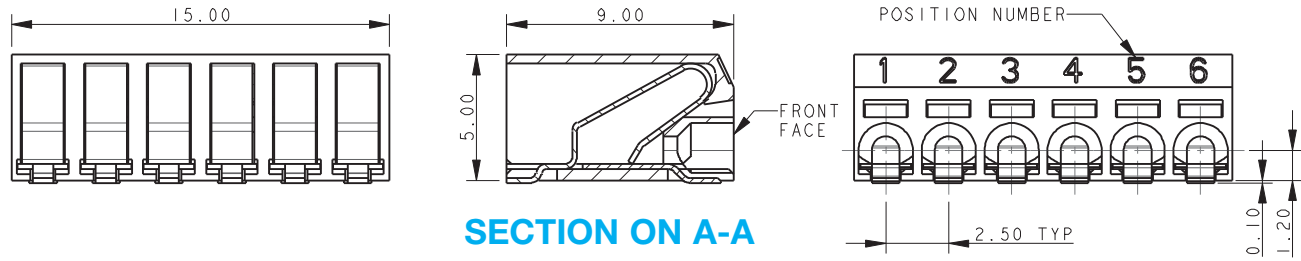

NOTES:

1. 9276 SIX WAY CONNECTOR, REFER TO ELCO SPECIFICATION 201-01-125 AND APPLICATION NOTES 201-01-127 FOR FURTHER DETAILS
2. INSULATOR MATERIAL: NYLON 46, GLASS FILLED, UL94 V-0, COLOR REFER TO PAGE 1
3. CONTACT MATERIAL: COPPER ALLOY, 0.20MM THICK, TIN PLATED.
4. OUTLINE OF CONNECTOR.
5. WIRE ASSEMBLY / EXTRACTION, REFER TO PAGE 8.
6. FRONT FACE OF CONNECTOR CAN BE IN LINE WITH EDGE OF PCB.
7. PACKING TAPE AND REEL, QUANTITY 1000 PER REEL.

6 WAY PCB BOARD LAYOUT

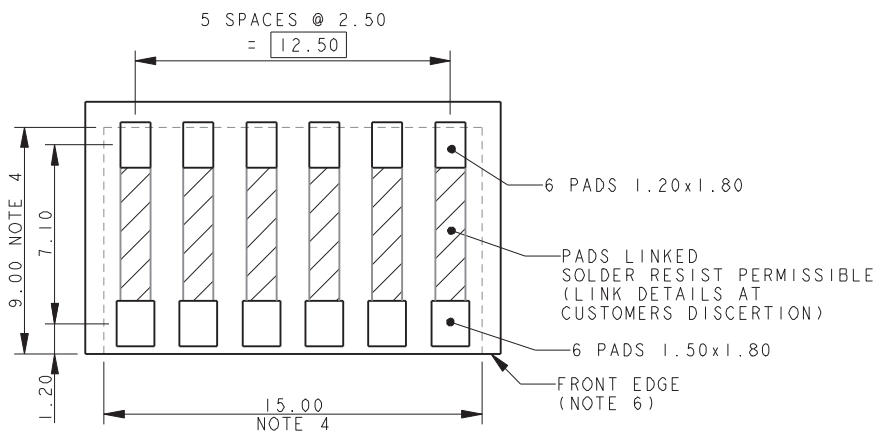

PACKING DETAILS

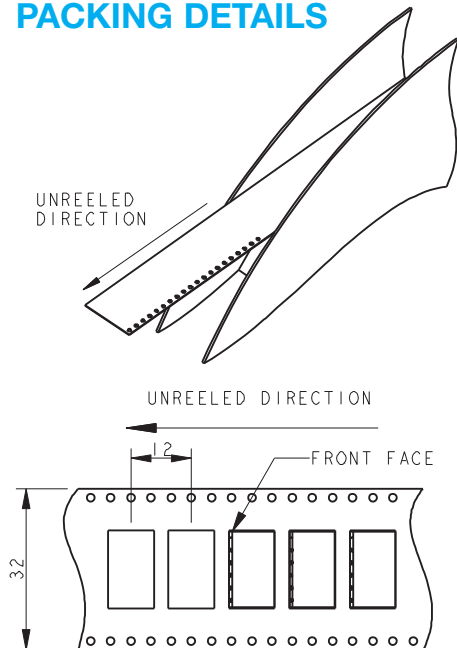

Discrete Wire-to-Board; Poke-Home



Series 9276

8 WAY WIRE TO BOARD CONNECTOR

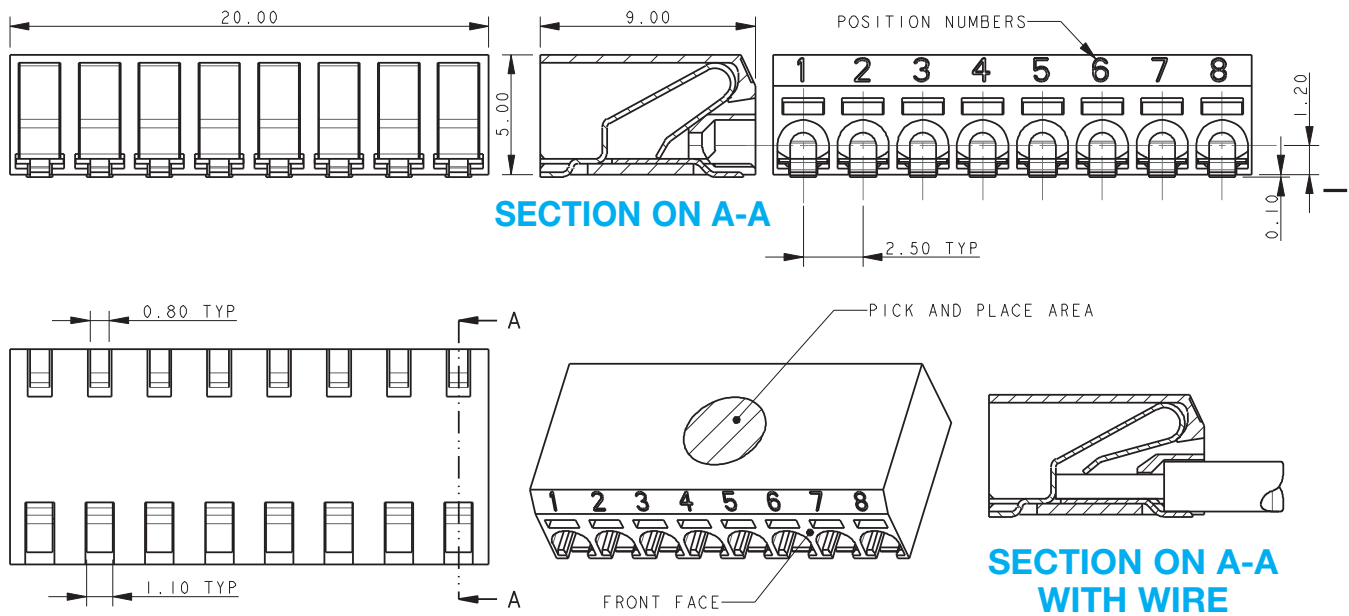

NOTES:

1. 9276 EIGHT WAY CONNECTOR, REFER TO ELCO SPECIFICATION 201-01-125 AND APPLICATION NOTES 201-01-127 FOR FURTHER DETAILS
2. INSULATOR MATERIAL: NYLON 46, GLASS FILLED, UL94 V-0, COLOR REFER TO PAGE 1
3. CONTACT MATERIAL: COPPER ALLOY, 0.20MM THICK, TIN PLATED.
4. OUTLINE OF CONNECTOR.
5. WIRE ASSEMBLY / EXTRACTION, REFER TO PAGE 8.
6. FRONT FACE OF CONNECTOR CAN BE IN LINE WITH EDGE OF PCB.
7. PACKING TAPE AND REEL, QUANTITY 1000 PER REEL.

PACKING DETAILS

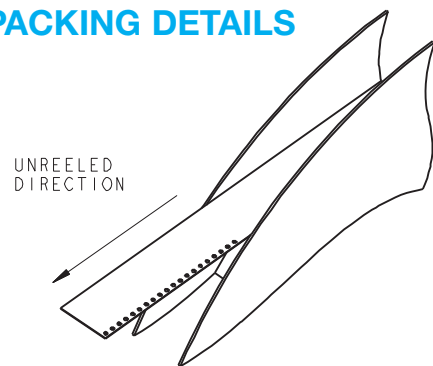

8 WAY PCB BOARD LAYOUT

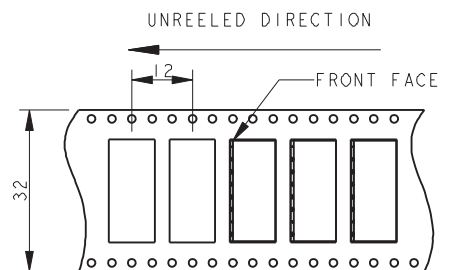
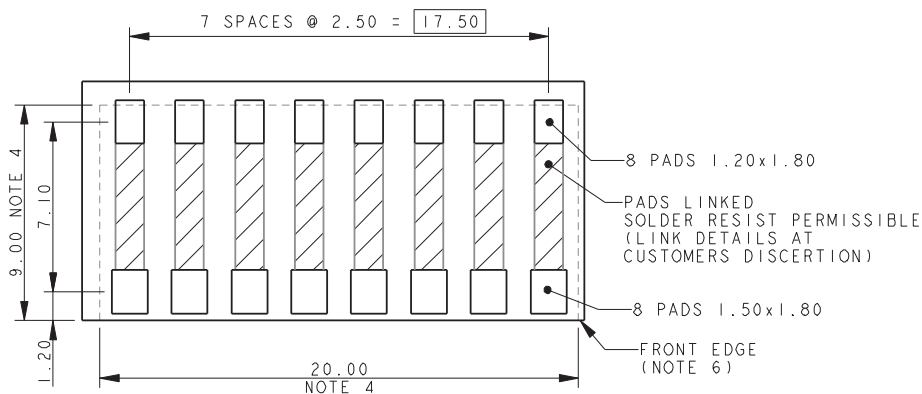

Discrete Wire-to-Board; Poke-Home



Series 9276

WIRE ASSEMBLY

FOR FURTHER DETAILS REFER TO APPLICATION NOTES 201-01-127

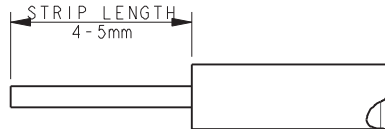

TRIM INSULATION.
DO NOT CRUSH CENTER OF WIRE.
STRANDED WIRES TWISTED TOGETHER BEFORE INSETION.
CHECK ALL STANDS OF WIRE ARE CORRECTLY ALIGNED
ATER THE INSULATION IS REMOVED.

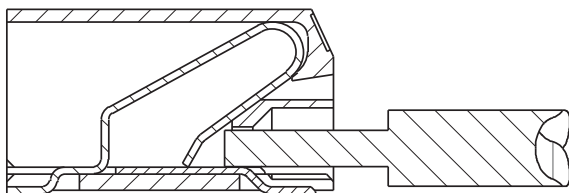

PUSH WIRE INTO HOLE IN FRONT OF CONNECTOR
DO NOT BEND CONNECTOR

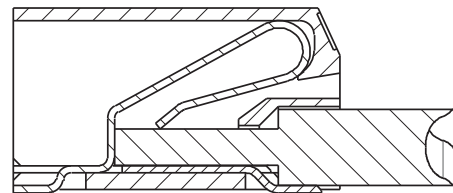

CONTINUED TO PUSH WIRE UNTIL STOP IS REACHED.

WIRE EXTRACTION

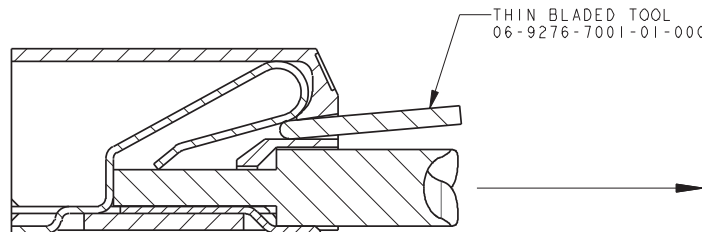

PUSH BLADE (NOT SHARP) INTO SLOT ABOVE WIRE.
WHEN WIRE IS FREE, PULL TO EXTRACT.

NOTICE: Specifications are subject to change without notice. Contact your nearest AVX Sales Office for the latest specifications. All statements, information and data given herein are believed to be accurate and reliable, but are presented without guarantee, warranty, or responsibility of any kind, expressed or implied. Statements or suggestions concerning possible use of our products are made without representation or warranty that any such use is free of patent infringement and are not recommendations to infringe any patent. The user should not assume that all safety measures are indicated or that other measures may not be required. Specifications are typical and may not apply to all applications.

© AVX Corporation

AMERICAS

AVX Myrtle Beach, SC
Tel: 843-448-9411

AVX Northwest, WA
Tel: 360-699-8746

AVX Midwest, IN
Tel: 317-861-9184

AVX Mid/Pacific, CA
Tel: 408-988-4900

AVX Northeast, MA
Tel: 617-479-0345

AVX Southwest, CA
Tel: 949-859-9509

AVX Canada
Tel: 905-238-3151

AVX South America
Tel: +55-11-4688-1960

EUROPE

AVX Limited, England
Tel: +44-1252-770000

AVX S.A.S., France
Tel: +33-1-69-18-46-00

AVX GmbH, Germany
Tel: +49-8131-9004-0

AVX SRL, Italy
Tel: +39-02-614-571

AVX Czech Republic
Tel: +420-57-57-57-521

AVX/ELCO UK
Tel: +44-1638-675000

ELCO Europe GmbH
Tel: +49-2741-299-0

AVX S.A., Spain
Tel: +34-91-63-97-197

ASIA-PACIFIC

AVX Benelux
Tel: +31-187-489-337

AVX/Kyocera HK Ltd.,
Taiwan
Tel: +886-2-2656-0258

AVX/Kyocera (M) Sdn Bhd,
Malaysia
Tel: +60-4228-1190

AVX/Kyocera International
Trading Co. Ltd.,
Shanghai
Tel: +86-21-3255 1933

AVX/Kyocera Asia Ltd.,
Shenzen
Tel: +86-755-3336-0615

AVX/Kyocera (S) Pte Ltd.,
Singapore
Tel: +65-6286-7555

AVX/Kyocera, Asia, Ltd.,
Hong Kong
Tel: +852-2363-3303

AVX/Kyocera Yuhan Hoesa,
South Korea
Tel: +82-2785-6504

AVX/Kyocera International
Trading Co. Ltd.,
Beijing
Tel: +86-10-6588-3528

AVX/Kyocera India
Liaison Office
Tel: +91-80-6450-0715

ASIA-KED

(KYOCERA Electronic Devices)

KED Hong Kong Ltd.
Tel: +852-2305-1080/1223

KED Hong Kong Ltd.
Shenzen
Tel: +86-755-3398-9600

KED Company Ltd.
Shanghai

Tel: +86-21-3255-1833

KED Hong Kong Ltd. Beijing
Tel: +86-10-5869-4655

KED Taiwan Ltd.
Tel: +886-2-2950-0268

KED Korea Yuhan Hoesa,
South Korea
Tel: +82-2-783-3604/6126

KED (S) Pte Ltd.
Singapore
Tel: +65-6509-0328

Kyocera Corporation
Japan
Tel: +81-75-604-3449



A KYOCERA GROUP COMPANY

<http://www.avx.com>

S-S927610M1010-N

Данный компонент на территории Российской Федерации

Вы можете приобрести в компании MosChip.

Для оперативного оформления запроса Вам необходимо перейти по данной ссылке:

<http://moschip.ru/get-element>

Вы можете разместить у нас заказ для любого Вашего проекта, будь то серийное производство или разработка единичного прибора.

В нашем ассортименте представлены ведущие мировые производители активных и пассивных электронных компонентов.

Нашей специализацией является поставка электронной компонентной базы двойного назначения, продукции таких производителей как XILINX, Intel (ex.ALTERA), Vicor, Microchip, Texas Instruments, Analog Devices, Mini-Circuits, Amphenol, Glenair.

Сотрудничество с глобальными дистрибьюторами электронных компонентов, предоставляет возможность заказывать и получать с международных складов практически любой перечень компонентов в оптимальные для Вас сроки.

На всех этапах разработки и производства наши партнеры могут получить квалифицированную поддержку опытных инженеров.

Система менеджмента качества компании отвечает требованиям в соответствии с ГОСТ Р ИСО 9001, ГОСТ РВ 0015-002 и ЭС РД 009

Офис по работе с юридическими лицами:

105318, г.Москва, ул.Щербаковская д.3, офис 1107, 1118, ДЦ «Щербаковский»

Телефон: +7 495 668-12-70 (многоканальный)

Факс: +7 495 668-12-70 (доб.304)

E-mail: info@moschip.ru

Skype отдела продаж:

moschip.ru

moschip.ru_4

moschip.ru_6

moschip.ru_9