

LUMAWISE LED HOLDER TYPE Z35

13.5*13.5mm and 12*15mm LED Board Sizes

TE Connectivity (TE)'s LUMAWISE LED Holder Type Z35 is suitable for LED board sizes 13.5*13.5mm and 12*15mm from various LED manufacturers. This LED Holder offers higher level of integration via a solderless connection to chip-on-board (COB) LEDs using standard pan-head and countersunk screws. The Type Z35 LED holder enables quick and easy LED assembly through tape-in LED retention and provides easy attachment of secondary optics. The LUMAWISE LED Holder is Zhaga book 11 inspired.



Applications

- Spot Lights
- Track Lights
- Recessed Downlights
- High Bay Lights
- Retrofit Lamps
- Wall Sconces
- Street Lights
- Runway Lights
- Architectural Lighting
- Reading lamps
- Sign and symbol luminaires
- Area and object lighting

Electrical

- Current rating: 3A (max)
- Voltage rating: 60 VDC

Mechanical

- Operating temperature range: -40 to +105 °C
- Uses M3 or #4-40 screws
- Poke-in electrical contact support: 18 AWG and 20 AWG solid, fused and stranded wire
- 35 mm diameter by 3.6 mm height (max)

Specifications

- Product specification: [108-133062](#)
- Application specifications: [114-133062](#)
- UL 8754 approved
- IEC 60838-2-2 approved

Materials

- Halogen free and red phosphorus free plastic housing material
- UL 94 V0 rating

Benefits

- Enable a higher level of integration through a solderless connection
- Achieve quick and easy LED assembly through tape-in LED retention
- Ease termination with integrated poke-in wire termination
- High-reflectivity, halogen free and red phosphorus free plastic housing material

Product Selection Information

Part Number	Description	Attachment
2213678-3	Z35 MINI LED HOLDER 12*15MM	Pan Head Screw
2213678-4	Z35 MINI LED HOLDER 12*15MM	Counter Sunk Screw

Part Number	Description	Attachment
2213678-5	Z35 MINI LED HOLDER 13.5*13.5MM	Pan Head Screw
2213678-6	Z35 MINI LED HOLDER 13.5*13.5MM	Counter Sunk Screw

Dimensions

All dimensions are in mm

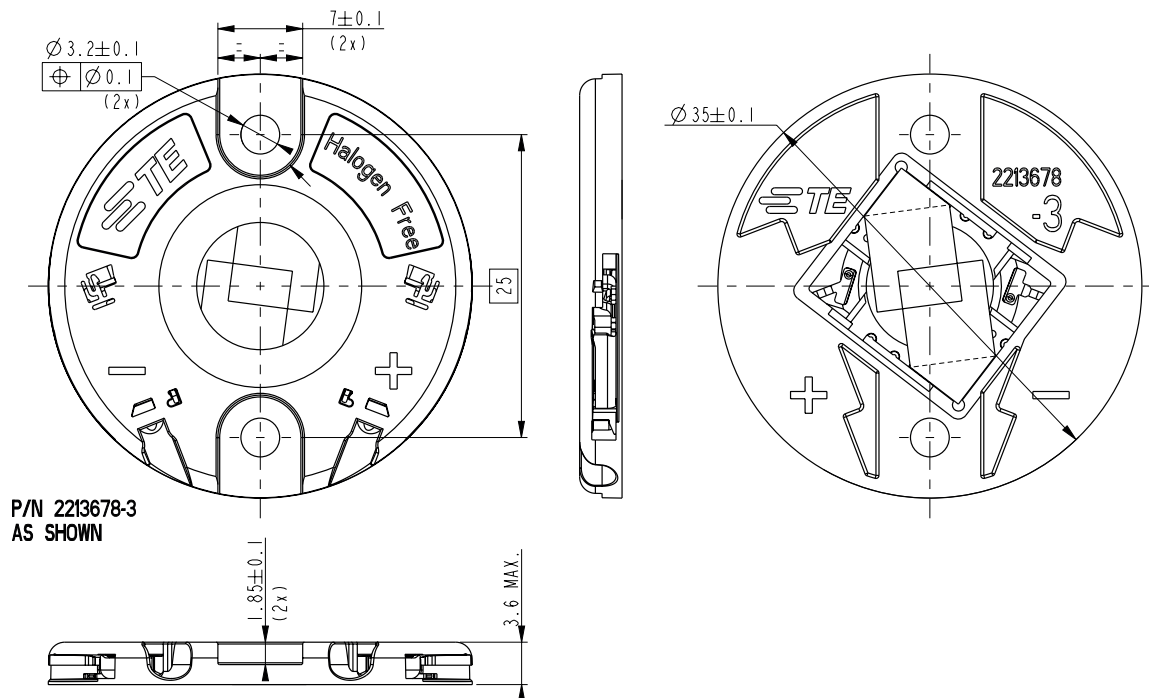

P/N 2213678-3
AS SHOWN

This drawing is subject to change. For latest version, please visit TE.com.

te.com

© 2017 TE Connectivity. All Rights Reserved. TE, TE Connectivity, and the TE connectivity (logo) are trademarks of the TE Connectivity Ltd. family of companies. Other logos, product and Company names mentioned herein may be trademarks of their respective owners.

While TE has made every reasonable effort to ensure the accuracy of the information in this brochure, TE does not guarantee that it is error-free, nor does TE make any other representation, warranty or guarantee that the information is accurate, correct, reliable or current. TE reserves the right to make any adjustments to the information contained herein at any time without notice. TE expressly disclaims all implied warranties regarding the information contained herein, including, but not limited to, any implied warranties of merchantability or fitness for a particular purpose. The dimensions in this catalog are for reference purposes only and are subject to change without notice. Specifications are subject to change without notice. Consult TE for the latest dimensions and design specifications.

1-1773882-6 FS 6/2017

USA: +1 (800) 522-6752
 Canada: +1 (905) 475-6222
 Mexico: +52 (0) 55-1106-0800
 Latin/S. America: +54 (0) 11-4733-2200
 Germany: +49 (0) 6251-133-1999
 UK: +44 (0) 800-267666
 France: +33 (0) 1-3420-8686
 The Netherlands: +31 (0) 73-6246-999
 China: +86 (0) 400-820-6015

Данный компонент на территории Российской Федерации

Вы можете приобрести в компании MosChip.

Для оперативного оформления запроса Вам необходимо перейти по данной ссылке:

<http://moschip.ru/get-element>

Вы можете разместить у нас заказ для любого Вашего проекта, будь то серийное производство или разработка единичного прибора.

В нашем ассортименте представлены ведущие мировые производители активных и пассивных электронных компонентов.

Нашей специализацией является поставка электронной компонентной базы двойного назначения, продукции таких производителей как XILINX, Intel (ex.ALTERA), Vicor, Microchip, Texas Instruments, Analog Devices, Mini-Circuits, Amphenol, Glenair.

Сотрудничество с глобальными дистрибьюторами электронных компонентов, предоставляет возможность заказывать и получать с международных складов практически любой перечень компонентов в оптимальные для Вас сроки.

На всех этапах разработки и производства наши партнеры могут получить квалифицированную поддержку опытных инженеров.

Система менеджмента качества компании отвечает требованиям в соответствии с ГОСТ Р ИСО 9001, ГОСТ РВ 0015-002 и ЭС РД 009

Офис по работе с юридическими лицами:

105318, г.Москва, ул.Щербаковская д.3, офис 1107, 1118, ДЦ «Щербаковский»

Телефон: +7 495 668-12-70 (многоканальный)

Факс: +7 495 668-12-70 (доб.304)

E-mail: info@moschip.ru

Skype отдела продаж:

moschip.ru

moschip.ru_4

moschip.ru_6

moschip.ru_9