

Voltage-Controlled Attenuator Module 100 to 2000 MHz

Rev. V3

Features

- FAST SWITCHING: < 0.2 μ sec, 10 TO 90% (TYP.)
< 1 μ sec, 0 TO 100% (TYP.)
- HIGH DYNAMIC RANGE: 40 dB TO 1000 MHz (TYP.)
- LOW VSWR: 1.4:1 (TYP.)

Description

The G30 attenuator is a discrete hybrid design, which uses thin film manufacturing processes for accurate performance and high reliability.

This design uses three pin diodes to provide a non linear attenuation response across a broadband frequency range. Both TO-8 and Surface Mount packages are hermetically sealed, and MIL-STD-883 environmental screening is available.

Ordering Information

Part Number	Package
G30	TO-8
SMG30	Surface Mount
CG30 **	SMA Connectorized

** The connectorized version is not RoHs compliant.

Product Image

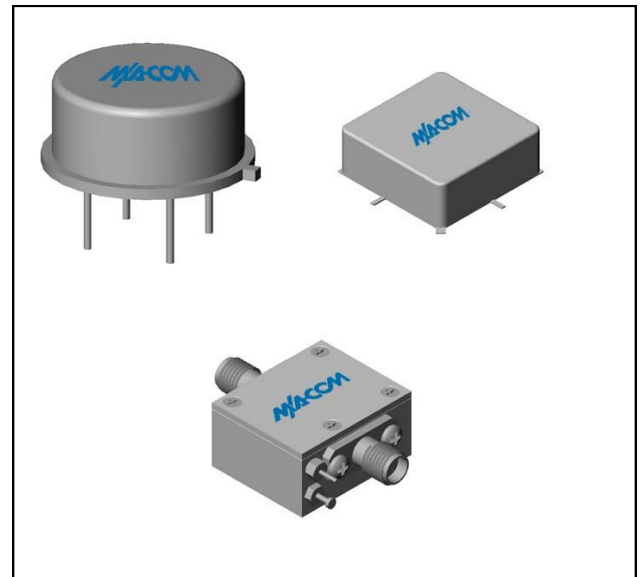

Electrical Specifications: $Z_0 = 50\Omega$, $V_{CC} = +15 V_{DC}$

Parameter	Units	Typical	Guaranteed	
		25°C	0° to 50°C	-54° to +85°C*
Frequency	MHz	5-2200	100-2000	100-2000
Maximum Attenuation Available (min)	100-500 MHz	>50	40	37
	500-1000 MHz	>44	35	32
	1000-2000 MHz	>38	30	27
Insertion Loss ($V_{ctrl} = +15 V$) (max)	100-500 MHz	<2.1	2.8	3.0
	500-1000 MHz	<2.3	3.0	3.2
	1000-2000 MHz	<3.0	3.5	3.8
VSWR (worst case in attenuation range)	0-25 dB Attenuation	1.4:1	2.0:1	2.0:1
	>25 dB Attenuation	<1.7:1	2.2:1	2.2:1
Flatness Over Frequency (max) (Attenuation = min to 15 dB, 100-1000 MHz)	100-1000 MHz	± 0.5	± 1.0	± 1.0
	1000-2000 MHz	± 1.0	± 1.5	± 1.7
Switching Speed (max.)	10% - 90%	<0.2	0.4	0.6
	0% - 100%	<1	2	3
Bias Voltage	Volts	+15	+15	+15
Bias Current (max)	mA	7	10	12
Control Voltage	Volts	0 to +15	0 to +15	0 to +15
Control Current (max)	mA	7	10	10

1 *Over temperature performance limits for part number CG30, guaranteed from 0°C to +50°C only.

Typical Performance Curves at +25°C

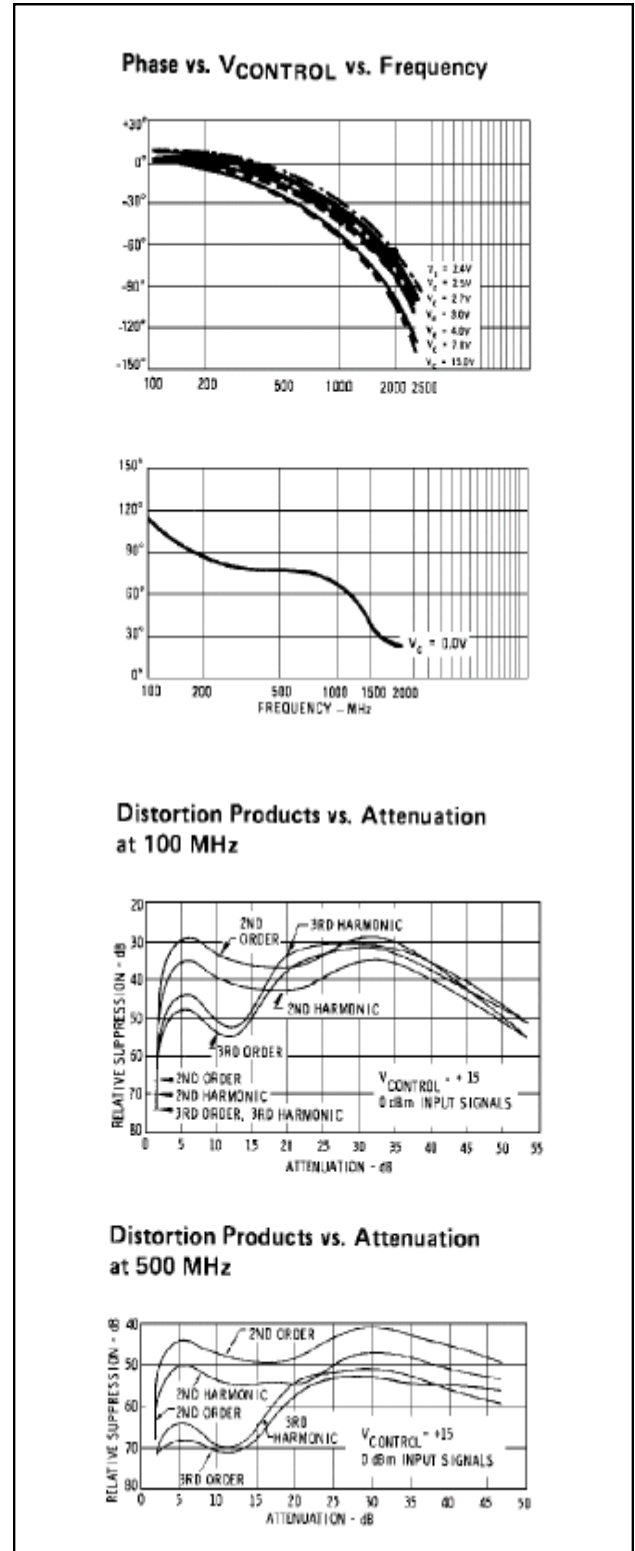
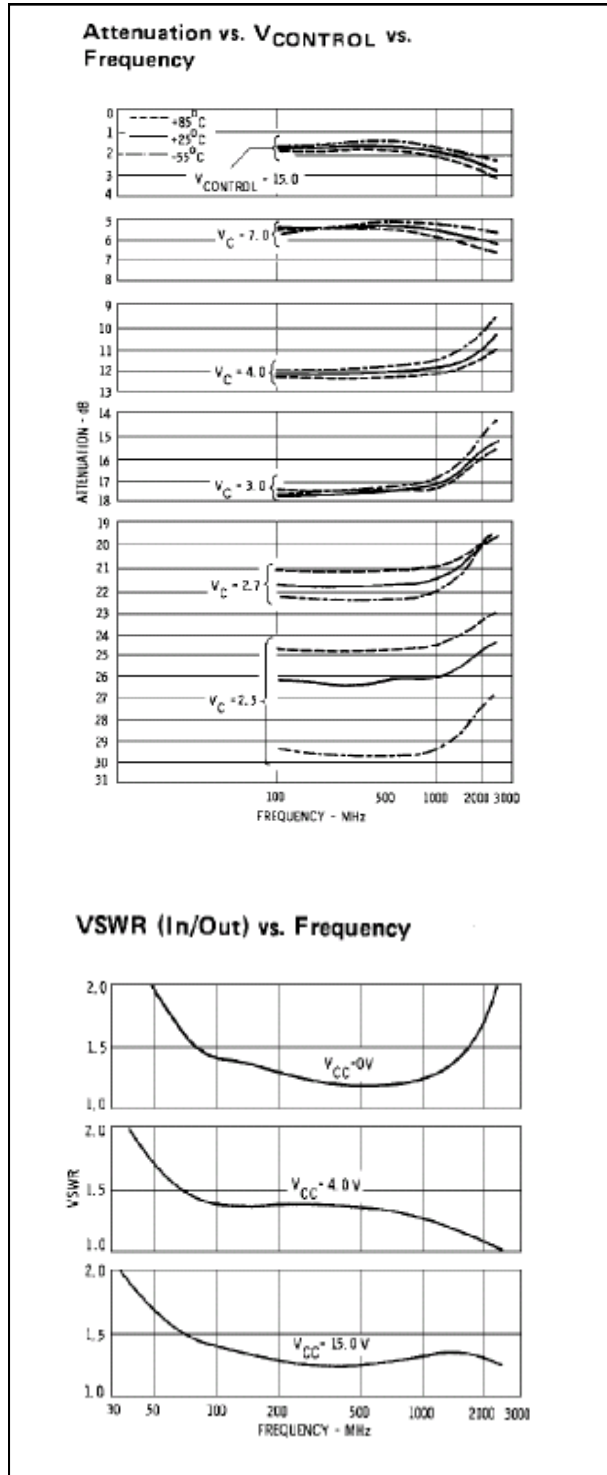

Voltage-Controlled Attenuator Module 100 to 2000 MHz

Rev. V3

Typical Performance Curves at +25°C

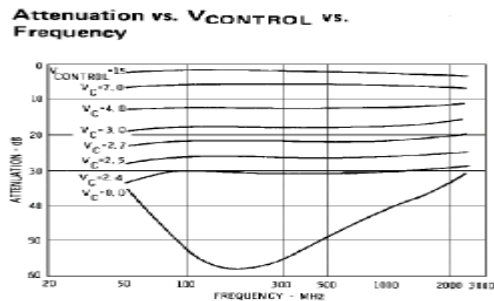
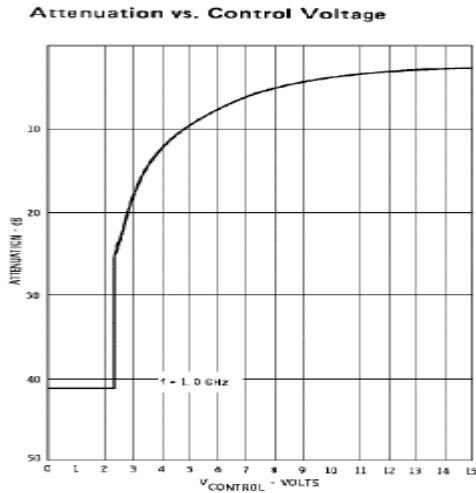

Absolute Maximum Ratings

Parameter	Absolute Maximum
Storage Temperature	-62°C to +125°C
Maximum Case Temperature	125°C
Maximum DC Voltage	+18 V
Maximum DC Bias Voltage	+20 V
Maximum Short Term RF Input power (1 minute max.)	200 mW
Maximum Peak Power (3 μsec max.)	1 W
"S" Series Burn-In Temperature (case)	+125°C

Outline Drawing: TO-8 *

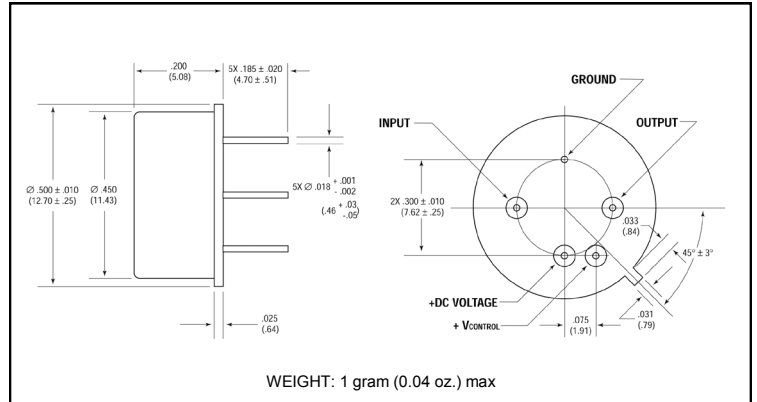

Outline Drawing: Surface Mount *

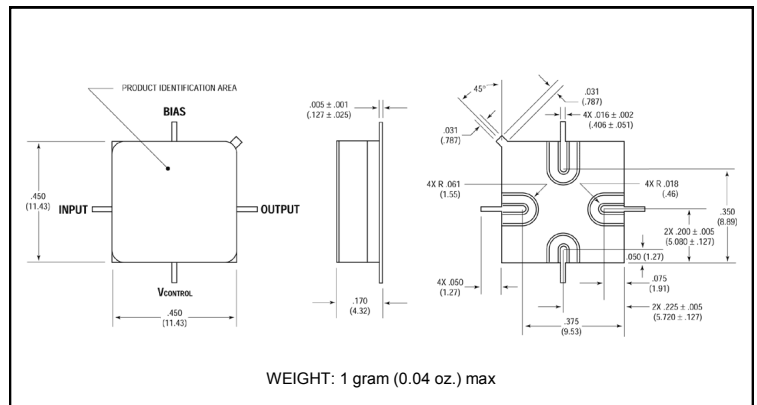

Outline Drawing: SMA Connectorized *

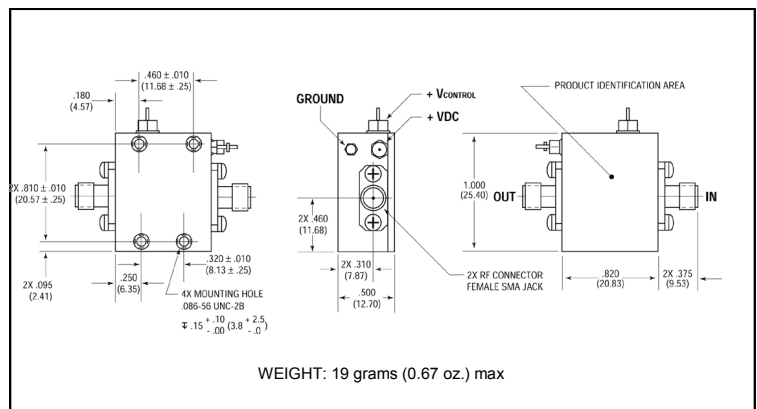

* Dimensions are inches (millimeters) ±0.015 (0.38) unless otherwise specified.

M/A-COM Technology Solutions Inc. All rights reserved.

Information in this document is provided in connection with M/A-COM Technology Solutions Inc ("MACOM") products. These materials are provided by MACOM as a service to its customers and may be used for informational purposes only. Except as provided in MACOM's Terms and Conditions of Sale for such products or in any separate agreement related to this document, MACOM assumes no liability whatsoever. MACOM assumes no responsibility for errors or omissions in these materials. MACOM may make changes to specifications and product descriptions at any time, without notice. MACOM makes no commitment to update the information and shall have no responsibility whatsoever for conflicts or incompatibilities arising from future changes to its specifications and product descriptions. No license, express or implied, by estoppel or otherwise, to any intellectual property rights is granted by this document.

THESE MATERIALS ARE PROVIDED "AS IS" WITHOUT WARRANTY OF ANY KIND, EITHER EXPRESS OR IMPLIED, RELATING TO SALE AND/OR USE OF MACOM PRODUCTS INCLUDING LIABILITY OR WARRANTIES RELATING TO FITNESS FOR A PARTICULAR PURPOSE, CONSEQUENTIAL OR INCIDENTAL DAMAGES, MERCHANTABILITY, OR INFRINGEMENT OF ANY PATENT, COPYRIGHT OR OTHER INTELLECTUAL PROPERTY RIGHT. MACOM FURTHER DOES NOT WARRANT THE ACCURACY OR COMPLETENESS OF THE INFORMATION, TEXT, GRAPHICS OR OTHER ITEMS CONTAINED WITHIN THESE MATERIALS. MACOM SHALL NOT BE LIABLE FOR ANY SPECIAL, INDIRECT, INCIDENTAL, OR CONSEQUENTIAL DAMAGES, INCLUDING WITHOUT LIMITATION, LOST REVENUES OR LOST PROFITS, WHICH MAY RESULT FROM THE USE OF THESE MATERIALS.

MACOM products are not intended for use in medical, lifesaving or life sustaining applications. MACOM customers using or selling MACOM products for use in such applications do so at their own risk and agree to fully indemnify MACOM for any damages resulting from such improper use or sale.

Данный компонент на территории Российской Федерации

Вы можете приобрести в компании MosChip.

Для оперативного оформления запроса Вам необходимо перейти по данной ссылке:

<http://moschip.ru/get-element>

Вы можете разместить у нас заказ для любого Вашего проекта, будь то серийное производство или разработка единичного прибора.

В нашем ассортименте представлены ведущие мировые производители активных и пассивных электронных компонентов.

Нашей специализацией является поставка электронной компонентной базы двойного назначения, продукции таких производителей как XILINX, Intel (ex.ALTERA), Vicor, Microchip, Texas Instruments, Analog Devices, Mini-Circuits, Amphenol, Glenair.

Сотрудничество с глобальными дистрибьюторами электронных компонентов, предоставляет возможность заказывать и получать с международных складов практически любой перечень компонентов в оптимальные для Вас сроки.

На всех этапах разработки и производства наши партнеры могут получить квалифицированную поддержку опытных инженеров.

Система менеджмента качества компании отвечает требованиям в соответствии с ГОСТ Р ИСО 9001, ГОСТ РВ 0015-002 и ЭС РД 009

Офис по работе с юридическими лицами:

105318, г.Москва, ул.Щербаковская д.3, офис 1107, 1118, ДЦ «Щербаковский»

Телефон: +7 495 668-12-70 (многоканальный)

Факс: +7 495 668-12-70 (доб.304)

E-mail: info@moschip.ru

Skype отдела продаж:

moschip.ru

moschip.ru_4

moschip.ru_6

moschip.ru_9