



PHANTOM[®] UHF ANTENNA OUTPERFORMS CONVENTIONAL MOBILE ANTENNAS IN MANY APPLICATIONS

Laird's unique patented Phantom[®] is a tough antenna for outdoor or indoor applications. Measuring only 3.4" tall, the Phantom UHF antenna's revolutionary design features vertical polarization components. The Phantom[®] provides low visibility, wide bandwidth and a low angle radiation pattern that is superior to traditional gain antennas in most applications.

The industry standard NMO mounting socket mates with all Laird magnetic, trunk lid, and hole mounts. A threaded permanent stud mount model is also available for vandal resistant mounting on brackets, panels, ceilings or any other kind of housing.

The Phantom[®] patented technology is beneficial when high performance is desired and extreme ruggedness and low profile is required.

FEATURES

- Phantom[®] outperforms a 3dB whip in many applications
- U.S. Patent Nos. 5,977,931 – 6,292,156 and 7,209,096

MARKETS

- Public safety
- Transportation
- Utility
- Military mobile
- Fixed radio applications

SPECIFICATIONS

ELECTRICAL

VSWR (Measured on 2' x 2' GP)	< 1.5:1 @ 10 MHz < 2.0:1 @ 20 MHz
Peak Gain	3 dBi
Maximum Power	100 W
Nominal Impedance	50 Ω
Polarization	Vertical
Pattern	Omnidirectional
Half-Power Beamwidth (Elevation° x Azimuth°)	146° x 360°
Coaxial Cable Length & Type	None
Terminations	NMO
Noise Suppressor	BlackHawk NS1535 1-35 VOLT, 15 Amp Noise Suppressor (Sold Separately)

Americas: +1.847.839.6907
IAS-AmericasEastSales@lairdtech.com

Europe: +44.1628.858941
IAS-EUSales@lairdtech.com

Asia: +86.21.5855.0827.127
IAS-AsiaSales@lairdtech.com

www.lairdtech.com

FORM FACTOR DRAWING

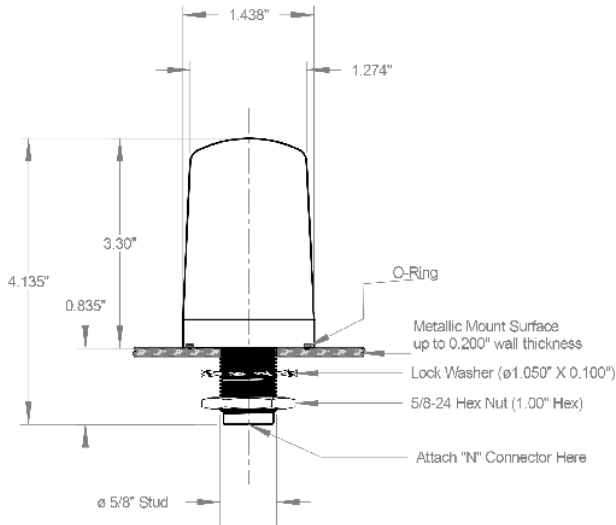

SPECIFICATIONS

MECHANICAL	
Height (initially)	3½" *
Diameter	1.438"
Weight	0.21 lbs.
Rated Wind Velocity	125mph (210 kph)
Rated Wind Velocity (with 0.5" radial ice)	85mph (137 kph)
Lateral Thrust @ 125mph Wind Velocity	57 lbs. (26kg)
Wind Resistance in Sq. Feet	0.0356 Sq. ft.
Material	ABS
Mounting Information	NMO or Permanent Mountable

* Add .835" for Permanent Mount option

Permanent Mounting Option:

Please order by antenna model and insert letter "P" to indicate permanent mounting option (TRA4503P).

MODEL AND ORDERING INFORMATION

MODEL	DESCRIPTION
TRA3003	300-305 MHz 3 dBi Phantom® ¾ NMO, White Radome
TRAB3003	300-305 MHz 3 dBi Phantom® ¾ NMO, Black Radome
TRA3803	380-400 MHz 3 dBi Phantom® ¾ NMO, White Radome
TRAB3803	380-400 MHz 3 dBi Phantom® ¾ NMO, Black Radome
TRA4063	406-425 MHz 3 dBi Phantom® ¾ NMO, White Radome
TRAB4063	406-425 MHz 3 dBi Phantom® ¾ NMO, Black Radome
TRA4103	410-430 MHz 3 dBi Phantom® ¾ NMO, White Radome
TRAB4103	410-430 MHz 3 dBi Phantom® ¾ NMO, Black Radome
TRA4303	430-450 MHz 3 dBi Phantom® ¾ NMO, White Radome
TRAB4303	430-450 MHz 3 dBi Phantom® ¾ NMO, Black Radome
TRA4503	450-470 MHz 3 dBi Phantom® ¾ NMO, White Radome
TRAB4503	450-470 MHz 3 dBi Phantom® ¾ NMO, Black Radome
TRA4703	470-490 MHz 3 dBi Phantom® ¾ NMO, White Radome
TRAB4703	470-490 MHz 3 dBi Phantom® ¾ NMO, Black Radome
TRA4903	490-512 MHz 3 dBi Phantom® ¾ NMO, White Radome
TRAB4903	490-512 MHz 3 dBi Phantom® ¾ NMO, Black Radome
Sealtube3	Heat shrink tubing 3"x1" DIA Elite install (use for jaw protector on installation wrench)

ANT-DS-PHANTOM UHF 0615

Any information furnished by Laird, Inc. and its agents is believed to be accurate and reliable. All specifications are subject to change without notice. Responsibility for the use and application of Laird materials rests with the end user. Laird makes no warranties as to the fitness, merchantability, suitability or non-infringement of any Laird materials or products for any specific or general uses. Laird shall not be liable for incidental or consequential damages of any kind. All Laird products are sold pursuant to the Laird Terms and Conditions of sale in effect from time to time, a copy of which will be furnished upon request. © Copyright 2015 Laird, Inc. All Rights Reserved. Laird, Laird Technologies, the Laird Technologies Logo, and other marks are trade marks or registered trade marks of Laird, Inc. or an affiliate company thereof. Other product or service names may be the property of third parties. Nothing herein provides a license under any Laird Technologies or any third party intellectual property rights.

Данный компонент на территории Российской Федерации

Вы можете приобрести в компании MosChip.

Для оперативного оформления запроса Вам необходимо перейти по данной ссылке:

<http://moschip.ru/get-element>

Вы можете разместить у нас заказ для любого Вашего проекта, будь то серийное производство или разработка единичного прибора.

В нашем ассортименте представлены ведущие мировые производители активных и пассивных электронных компонентов.

Нашей специализацией является поставка электронной компонентной базы двойного назначения, продукции таких производителей как XILINX, Intel (ex.ALTERA), Vicor, Microchip, Texas Instruments, Analog Devices, Mini-Circuits, Amphenol, Glenair.

Сотрудничество с глобальными дистрибьюторами электронных компонентов, предоставляет возможность заказывать и получать с международных складов практически любой перечень компонентов в оптимальные для Вас сроки.

На всех этапах разработки и производства наши партнеры могут получить квалифицированную поддержку опытных инженеров.

Система менеджмента качества компании отвечает требованиям в соответствии с ГОСТ Р ИСО 9001, ГОСТ РВ 0015-002 и ЭС РД 009

Офис по работе с юридическими лицами:

105318, г.Москва, ул.Щербаковская д.3, офис 1107, 1118, ДЦ «Щербаковский»

Телефон: +7 495 668-12-70 (многоканальный)

Факс: +7 495 668-12-70 (доб.304)

E-mail: info@moschip.ru

Skype отдела продаж:

moschip.ru

moschip.ru_4

moschip.ru_6

moschip.ru_9