



Photocoupler

Product Data Sheet

6N135 / 6N136 series

Spec No.: DS70-2008-0032

Effective Date: 12/15/2009

Revision: -

LITE-ON DCC

RELEASE

BNS-OD-FC001/A4

6N135, 6N136 Single Channel, High Speed Optocouplers



Jan.2009

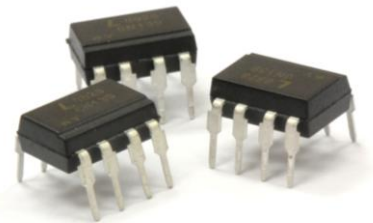

Description

The 6N135/6 consists of a high efficient AlGaAs Light Emitting Diode and a high speed optical detector. This design provides excellent AC and DC isolation between the input and output sides of the Optocoupler. Connection for the bias of the photodiode improves the speed that of a conventional phototransistor coupler by reducing the base-collector capacitances. The internal shield ensures high common mode transient immunity. A guaranteed common mode transient immunity is up to $1KV/\mu sec$.

Features

- High speed – 1MBd typical
- Available in Dual-in-line, Wide lead spacing, Surface mounting package.
- Storable output.
- UL, CSA approval

Functional Diagram

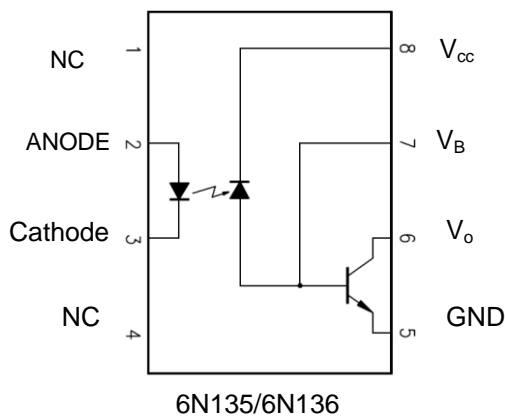

Truth Table (Positive Logic)

LED	OUT
ON	L
OFF	H

A 0.1 μ F bypass Capacitor must be connected between Pin8 and Pin5

Application

- High Voltage Isolation
- Isolation in line receivers
- Feedback element in switching mode power supplier
- Power transistor isolation in motor drives
- Interface between Microprocessor system, computer and their peripheral
- Replace pulse transformers.
- Replace slower optocoupler isolators.

Ordering Information

Part	Option	Minimum CMR		CTR	Remarks
		dV/dt (V/ μ s)	V _{CM} (V)		
6N135	M	1000	10	7	Single Channel, DIP-8
	S				Single Channel, Wide Lead Spacing
6N136	M	1000	10	19	Single Channel, SMD-8
	S				Single Channel, DIP-8
					Single Channel, Wide Lead Spacing
					Single Channel, SMD-8

Package Dimensions

8-pin DIP Package (6N135 / 6N136)

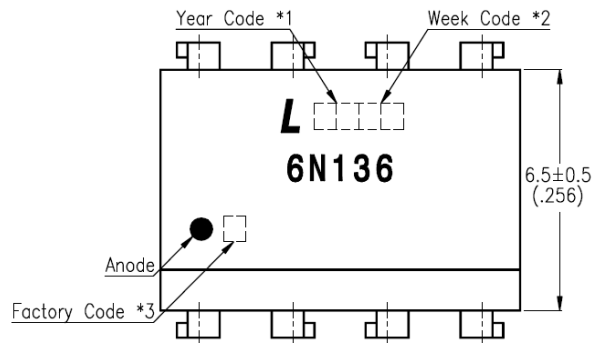
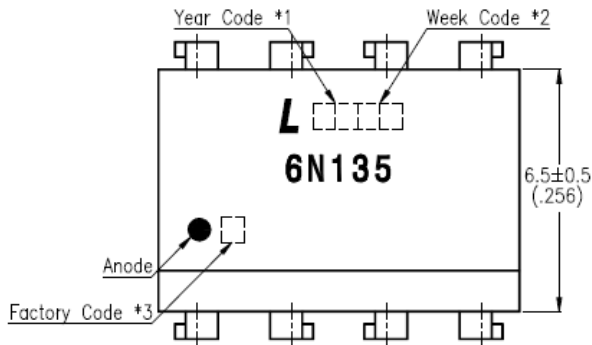

- *1. Year date code.
 - *2. 2-digit work week.
 - *3. Factory identification mark
(Z : Taiwan, Y : Thailand).
- Dimensions are in Millimeters and (Inches).

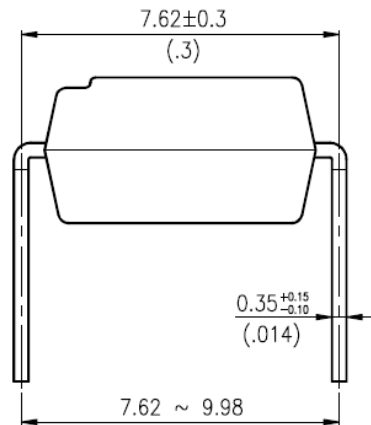
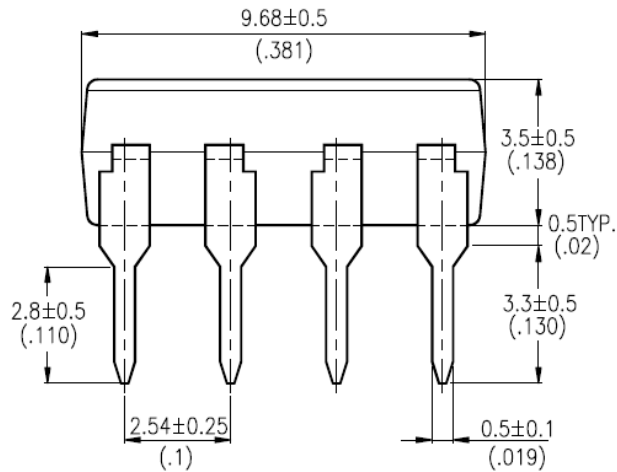

Package Dimensions

8-pin DIP Wide Lead Spacing Package (6N135M / 6N136M)

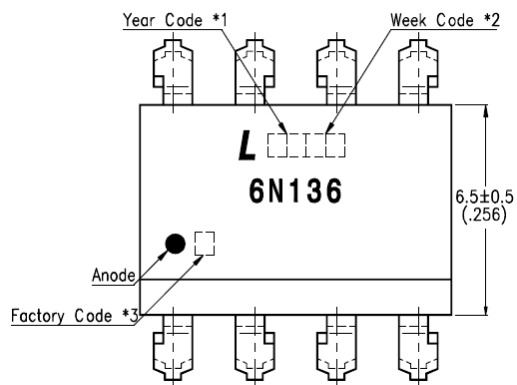
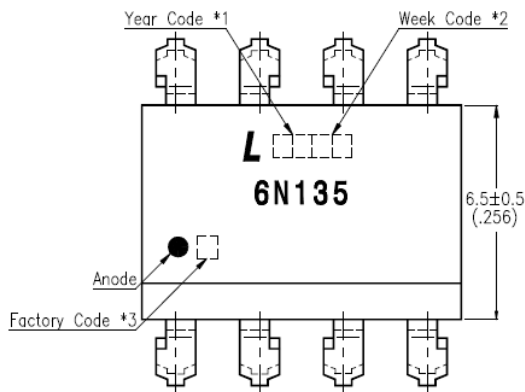

- *1. Year date code.
- *2. 2-digit work week.
- *3. Factory identification mark
(Z : Taiwan, Y : Thailand).

Dimensions are in Millimeters and (Inches).

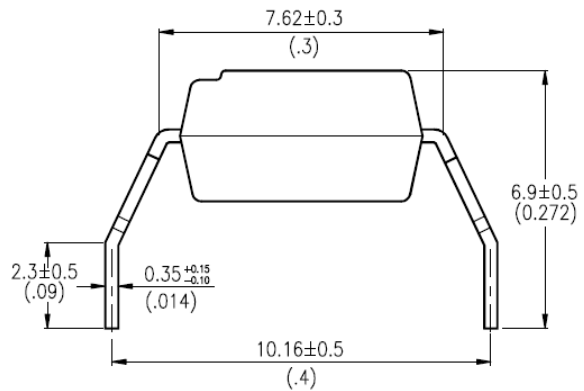
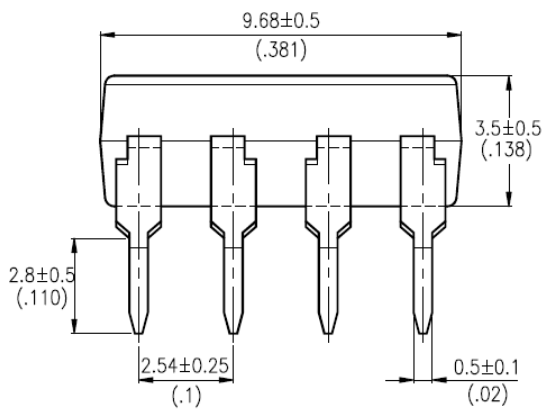

Package Dimensions

8-pin DIP Surface Mount Package (6N135S / 6N136S)

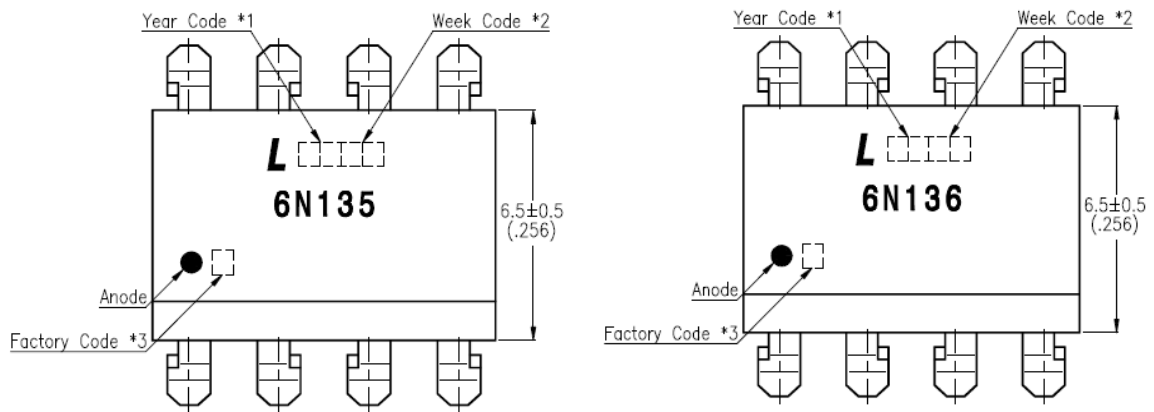

- *1. Year date code.
 - *2. 2-digit work week.
 - *3. Factory identification mark
(Z : Taiwan, Y : Thailand).
- Dimensions are in Millimeters and (Inches).

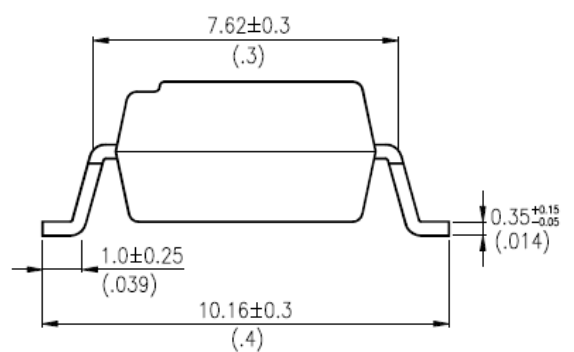
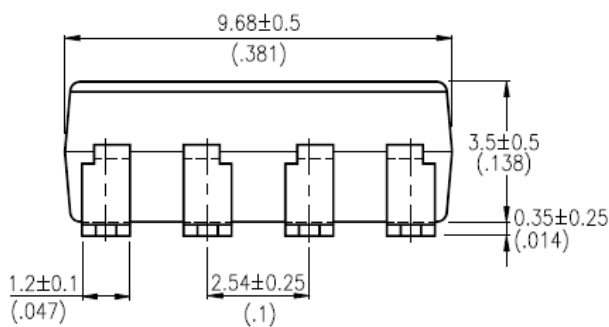

Taping Dimensions

6N135S/136S-TA

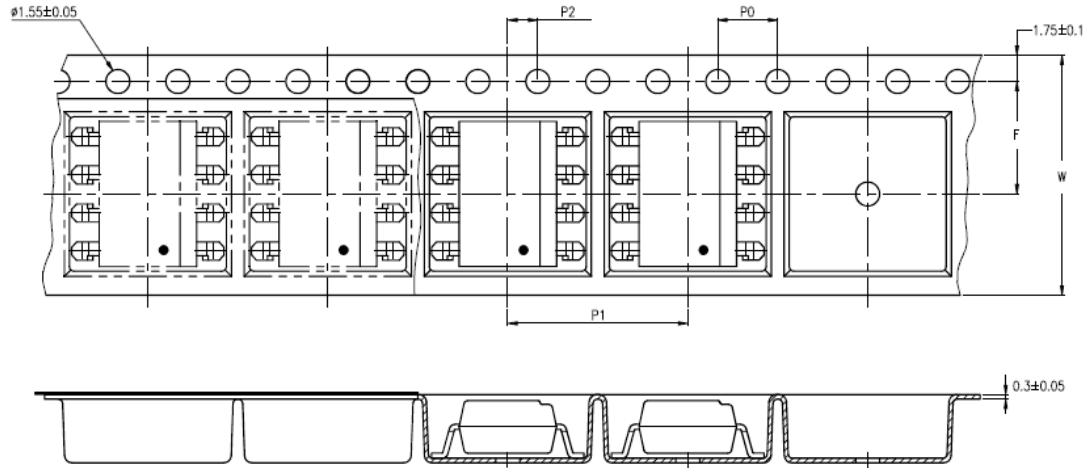

6N135S/136S-TA1

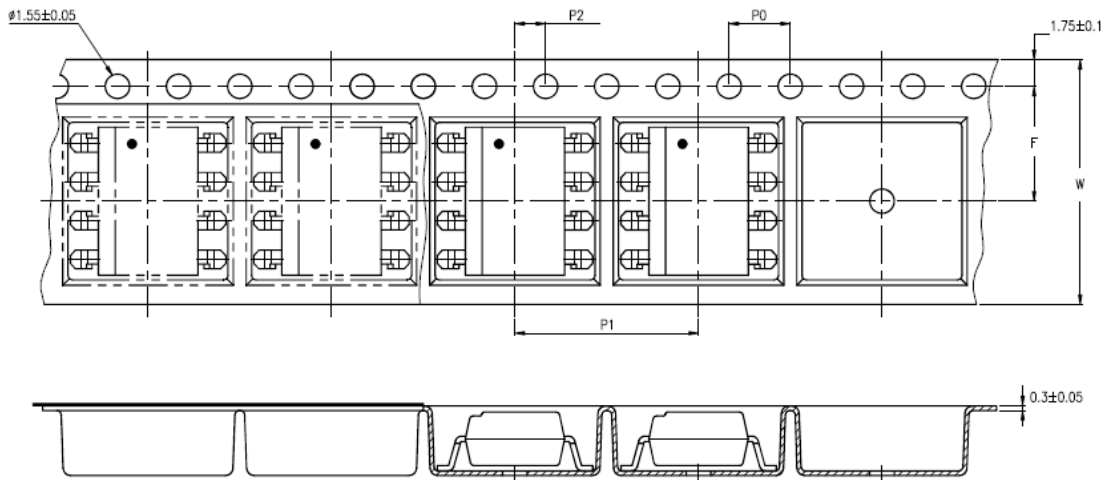

Description	Symbol	Dimensions in millimeters (inches)
Tape wide	W	16 ± 0.3 (.63)
Pitch of sprocket holes	P0	4 ± 0.1 (.15)
Distance of compartment	F	7.5 ± 0.1 (.295)
Distance of compartment to compartment	P1	2 ± 0.1 (.079)

Recommended Lead Free Reflow Profile

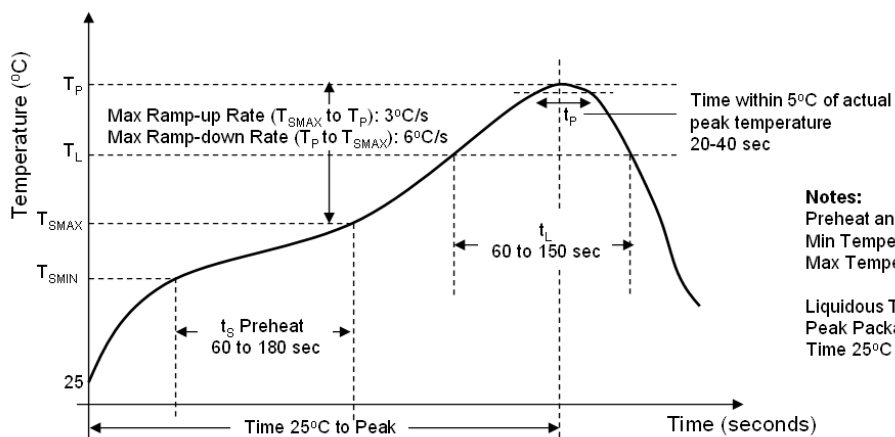

Notes:
Preheat and Soak:
Min Temperature (T_{SMIN}) = 150°C
Max Temperature (T_{SMAX}) = 200°C

Liquidous Temperature (T_L) = 217°C
Peak Package Body Temperature = 260°C
Time 25°C to Peak Temperature = 8 minutes max.

Absolute Maximum Ratings*1

Parameter	Symbol	Min	Max	Units	Note
Storage Temperature	T_{ST}	-55	125	°C	
Operating Temperature	T_A	-40	85	°C	
Isolation Voltage	V_{ISO}	5000		V_{RMS}	
Supply Voltage	V_{CC}		15	V	
Lead Solder Temperature * 2			260	°C	2
Input					
Average Forward Input Current	I_F		25	mA	
Reverse Input Voltage	V_R		5	V	
Input Power Dissipation	P_I		45	mW	
Output					
Output Collector Current	I_O		8	mA	
Output Collector Voltage	V_O	-0.5	20	V	
Output Collector Power Dissipation	P_O		100	mW	

1. Ambient temperature = 25°C, unless otherwise specified. Stresses exceeding the absolute maximum ratings can cause permanent damage to the device. Exposure to absolute maximum ratings for long periods of time can adversely affect reliability.

2. 260°C for 10 seconds. Refer to Lead Free Reflow Profile.

Electrical Specifications

Parameters	Test Condition	Symbol	Device	Min	Typ	Max	Units
Input							
Input Forward Voltage	$I_F=16\text{mA}$, $T_A=25^\circ\text{C}$	V_F	6N135		1.4	1.7	V
Input Reverse Voltage	$I_R=10\mu\text{A}$	BV_R	6N136	5			V
Detector							
Current transfer ratio	$I_F=16\text{mA}$; $V_{CC}=4.5\text{V}$; $T_A=25^\circ\text{C}$; $V_o=0.4\text{V}$	CTR	6N135	7	18	50	%
			6N136	19	24	50	
Logic low output voltage output voltage	$I_F=16\text{mA}$; $V_{CC}=4.5\text{V}$; $I_o=1.1\text{mA}$; $T_A=25^\circ\text{C}$	V_{OL}	6N135		0.18	0.4	V
	$I_F=16\text{mA}$; $V_{CC}=4.5\text{V}$; $I_o=3\text{mA}$; $T_A=25^\circ\text{C}$		6N136		0.25	0.4	
Logic high output current	$I_F=0\text{mA}$, $V_o=V_{CC}=5.5\text{V}$ $T_A=25^\circ\text{C}$	I_{OH}	6N135			0.5	μA
	$I_F=0\text{mA}$, $V_o=V_{CC}=15\text{V}$ $T_A=25^\circ\text{C}$		6N136			1	
Logic low supply current	$I_F=16\text{mA}$, $V_o=\text{open}$ ($V_{CC}=15\text{V}$)	I_{ccl}	6N135 6N136		400		μA
Logic high supply current	$I_F=0\text{mA}$, $V_o=\text{open}$; $T_A=25^\circ\text{C}$ ($V_{CC}=15\text{V}$)	I_{cch}	6N135 6N136			1	μA

*All Typical at $T_A=25^\circ\text{C}$

Property of Lite-on Only

Switching Specifications

$T_A=0\sim 70^{\circ}\text{C}$, $V_{CC}=5\text{V}$, unless otherwise specified.

Parameter	Test Condition	Symbol	Device	Min	Typ	Max	Units
Propagation Delay Time to Low Output Level	$T_A=25^{\circ}\text{C}$ ($R_L=4.1\text{K}\Omega$, $I_F=16\text{mA}$)	t_{PHL}	6N135		0.09	1.5	μs
	$T_A=25^{\circ}\text{C}$ ($R_L=1.9\text{K}\Omega$, $I_F=16\text{mA}$)		6N136		0.1	0.8	μs
Propagation Delay Time to High Output Level	$T_A=25^{\circ}\text{C}$ ($R_L=4.1\text{K}\Omega$, $I_F=16\text{mA}$)	t_{PLH}	6N135		0.8	1.5	μs
	$T_A=25^{\circ}\text{C}$ ($R_L=1.9\text{K}\Omega$, $I_F=16\text{mA}$)		6N136		0.4	0.8	μs
Logic High Common Mode Transient Immunity	$I_F=0\text{mA}$; $V_{\text{CM}}=10\text{Vp-p}$; $R_L=4.1\text{K}\Omega$; $T_A=25^{\circ}\text{C}$	$ CM_H $	6N135	1			$\text{KV}/\mu\text{s}$
	$I_F=0\text{mA}$; $V_{\text{CM}}=10\text{Vp-p}$; $R_L=1.9\text{K}\Omega$; $T_A=25^{\circ}\text{C}$		6N136	1			$\text{KV}/\mu\text{s}$
Logic Low Common Mode Transient Immunity	$I_F=0\text{mA}$; $V_{\text{CM}}=10\text{Vp-p}$; $R_L=4.1\text{K}\Omega$; $T_A=25^{\circ}\text{C}$	$ CM_L $	6N135	1			$\text{KV}/\mu\text{s}$
	$I_F=0\text{mA}$; $V_{\text{CM}}=10\text{Vp-p}$; $R_L=1.9\text{K}\Omega$; $T_A=25^{\circ}\text{C}$		6N136	1			$\text{KV}/\mu\text{s}$

*All Typical at $T_A=25^{\circ}\text{C}$

Isolation Characteristics

Parameter	Test Condition	Symbol	Min	Typ	Max	Units
Input-Output Insulation Leakage Current	45% RH, t = 5s, $V_{I-O} = 3kV$ DC, $T_A = 25^{\circ}C$	I_{I-O}			1.0	μA
Withstand Insulation Test Voltage	$RH \leq 50\%$, t = 1min, $T_A = 25^{\circ}C$	V_{ISO}	5000			V_{RMS}
Input-Output Resistance	$V_{I-O} = 500V$ DC	R_{I-O}		10^{12}		Ω

*All Typical at $T_A = 25^{\circ}C$

Notes

1. A $0.1\mu F$ or bigger bypass capacitor for V_{CC} is needed as shown in Fig.1
2. Current Transfer Ratio is defined as the ratio of output collector current I_o , to the forward LED input current I_F , times 100.
3. The $1.9K\Omega$ load represents 1TTL unit load of 1.6mA and the $5.6K\Omega$ pull-up resistor.
4. The $4.1K\Omega$ load represents 1LSTTL unit load of 0.36mA and the $6.1K\Omega$ pull-up resistor.

Switching Time Test Circuit

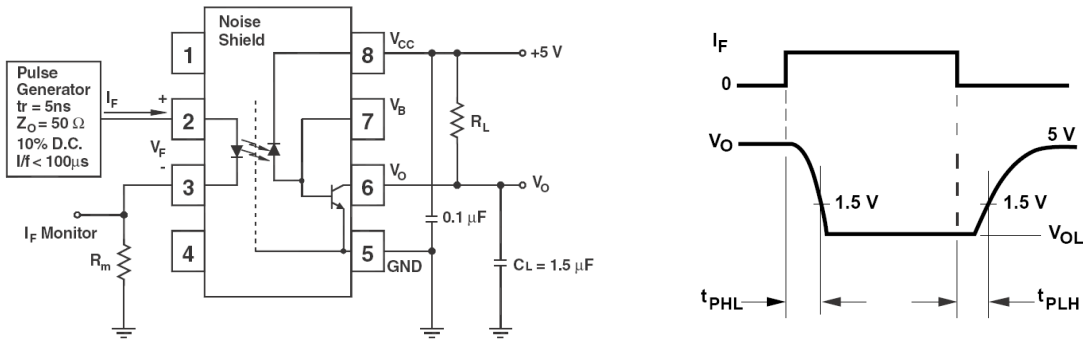

Figure 1: Single Channel Test Circuit for t_{PHL} and t_{PLH}

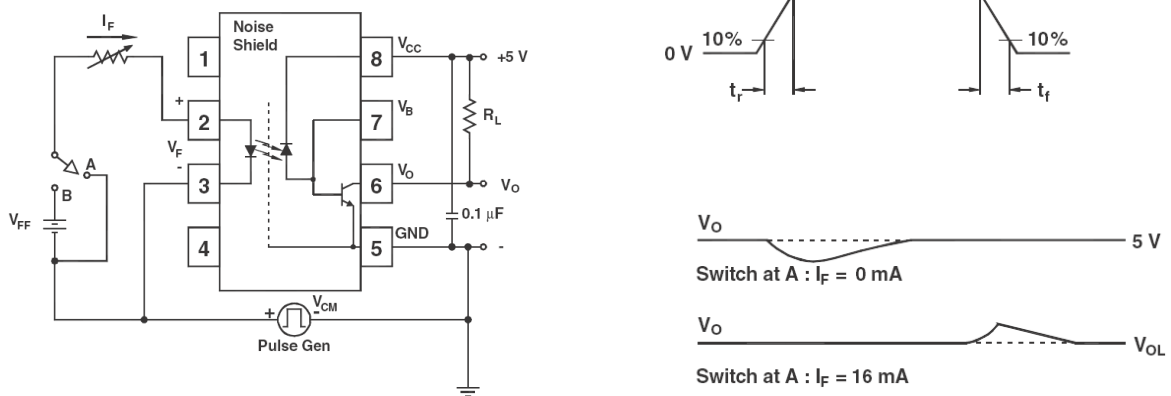

Figure 2: Single Channel Test Circuit for Common Mode Transient Immunity

Characteristics Curves

Figure 3: DC and pulsed transfer characteristics

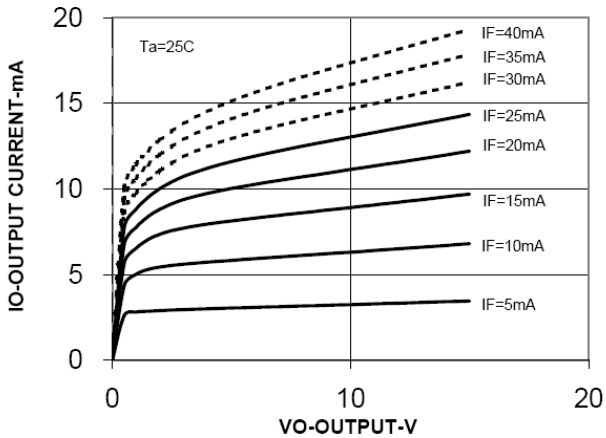

Figure 6: Current transfer ratio vs. input

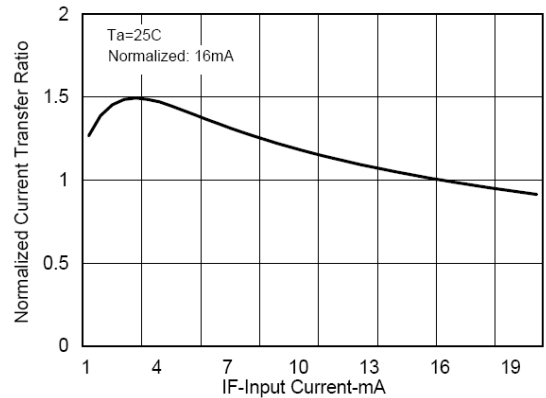

Figure 4: Input current vs. forward voltage

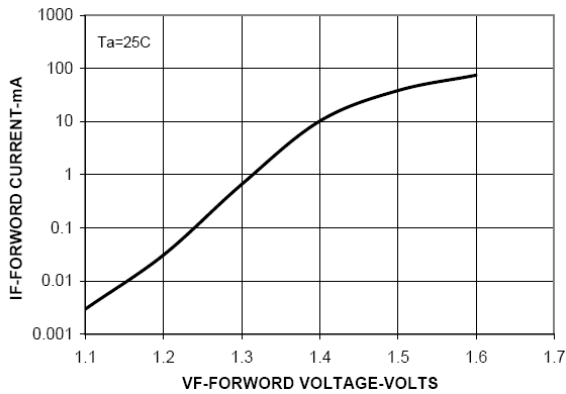

Figure 7: Current transfer ratio vs. temperature

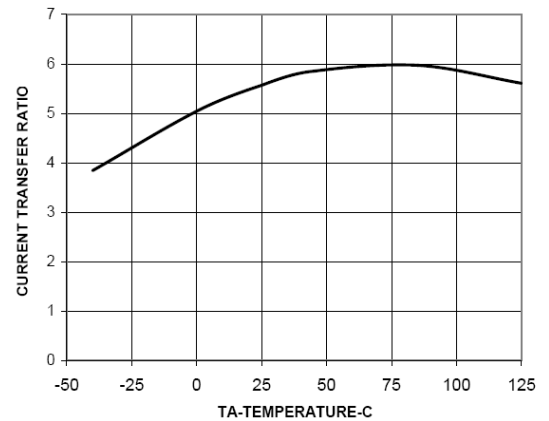

Figure 5: Logic high output current vs. temperature

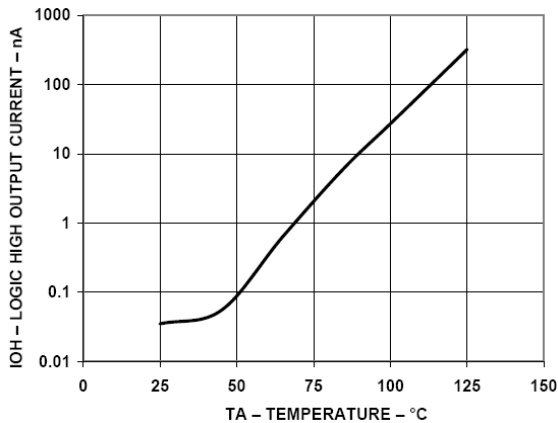
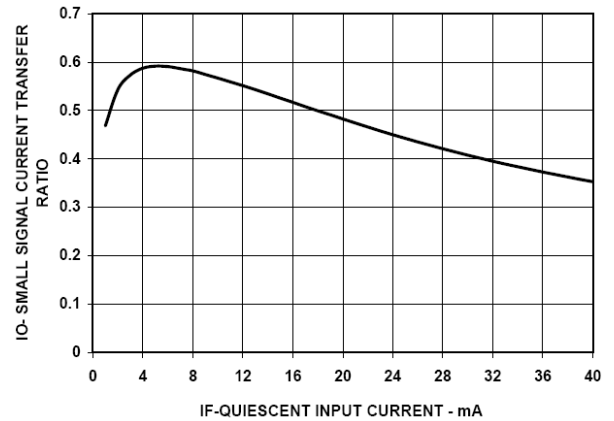

Figure 8: Small-signal current transfer ratio vs. quiescent current



Property of Lite-on Only

Characteristics Curves

Figure 9: Propagation delay time vs. temperature

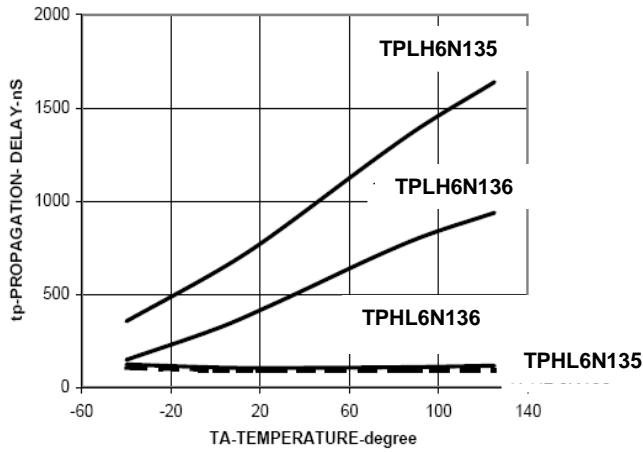
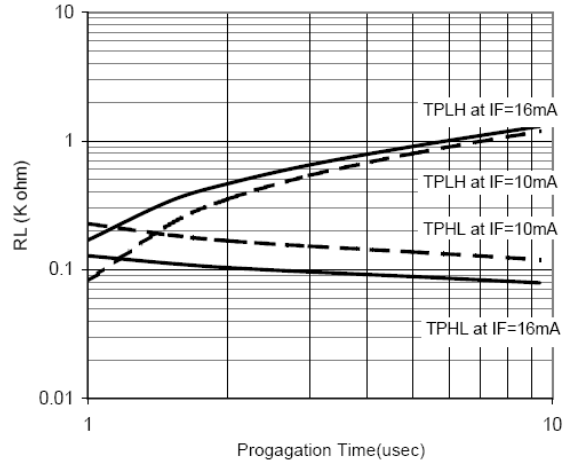

Figure 10: Propagation delay time vs. load resistance



Notice

Specifications of the products displayed herein are subject to change without notice.

The products shown in this publication are designed for the general use in electronic applications such as office automation equipment, communications devices, audio/visual equipment, electrical instrumentation and application. For equipment/devices where high reliability or safety is required, such as space applications, nuclear power control equipment, medical equipment, etc, please contact our sales representatives.

Mouser Electronics

Authorized Distributor

Click to View Pricing, Inventory, Delivery & Lifecycle Information:

[Lite-On:](#)

[6N135S-TA1](#) [6N135M](#) [6N135S](#) [6N136M](#) [6N136](#) [6N136S-TA1](#) [6N136S](#) [6N135](#)

Данный компонент на территории Российской Федерации

Вы можете приобрести в компании MosChip.

Для оперативного оформления запроса Вам необходимо перейти по данной ссылке:

<http://moschip.ru/get-element>

Вы можете разместить у нас заказ для любого Вашего проекта, будь то серийное производство или разработка единичного прибора.

В нашем ассортименте представлены ведущие мировые производители активных и пассивных электронных компонентов.

Нашей специализацией является поставка электронной компонентной базы двойного назначения, продукции таких производителей как XILINX, Intel (ex.ALTERA), Vicor, Microchip, Texas Instruments, Analog Devices, Mini-Circuits, Amphenol, Glenair.

Сотрудничество с глобальными дистрибьюторами электронных компонентов, предоставляет возможность заказывать и получать с международных складов практически любой перечень компонентов в оптимальные для Вас сроки.

На всех этапах разработки и производства наши партнеры могут получить квалифицированную поддержку опытных инженеров.

Система менеджмента качества компании отвечает требованиям в соответствии с ГОСТ Р ИСО 9001, ГОСТ РВ 0015-002 и ЭС РД 009

Офис по работе с юридическими лицами:

105318, г.Москва, ул.Щербаковская д.3, офис 1107, 1118, ДЦ «Щербаковский»

Телефон: +7 495 668-12-70 (многоканальный)

Факс: +7 495 668-12-70 (доб.304)

E-mail: info@moschip.ru

Skype отдела продаж:

moschip.ru

moschip.ru_4

moschip.ru_6

moschip.ru_9