

N8700 Series System DC Power Supplies

N8731A-42A (3.3 kW), N8754A-62A (5 kW)

Family of Affordable Basic System DC Power Supplies

The Keysight Technologies, Inc. N8700 series system DC power supplies give you just the right performance — at just the right price — in a compact (2 U) package. This family of affordable 3300 W and 5000 W single-output programmable DC power supplies consists of 21 models for simple DC power applications.

They provide stable output power, built-in voltage and current measurement, and output voltage and current from 8 V to 600 V and 5.5 A to 400 A.

These economical supplies offer many system-ready features like multiple standard I/O interfaces to simplify and accelerate test-system development for R&D, design validation, and manufacturing engineers in the aerospace/defense, automotive, component and communications industries.

Small, high-density package saves you rack space

The N8700 provides up to 5200 W in a small space-saving 2 U-high, 19-inch-wide package. Its air vents are in the front and rear (not on the top or bottom), so you can stack other instruments directly above or below it to save valuable rack space.

Features

- 21 Models: 3300 W and 5000 W output power
- Up to 600 V and up to 400 A
- Small, high density 2 U package
- Built-in voltage and current measurement
- Full protection from over-voltage and over-current
- Flexible AC input voltage options
- LAN, USB, and GPIB interfaces standard



Easy front-panel operation

You can quickly and easily operate the power supply with its rotary knobs and buttons. Using the front-panel controls, you can make coarse or fine adjustments of output voltage and current, protection settings, and set power-on states (last setting memory or factory default setting). The output voltage and current are displayed simultaneously, and LED indicators show power supply status and operating modes. You can lock the front panel controls to protect against accidental power-supply parameter changes.

Extensive device protection

To safeguard your device from damage, the N8700 Series power supplies provide over-temperature, over-current and over-voltage protection (OVP) to shut down the power supply output when a fault condition occurs. They also offer an under-voltage limit (UVL) that prevents adjustment of the output voltage below a certain limit. The combination of UVL and OVP capabilities lets you create a protection window for sensitive load circuitry.

Simplify system connections

The N8700 Series power supplies comes standard with GPIB, Ethernet/LAN, and USB 2.0 interfaces giving you the flexibility to use your I/O interface of choice today and safeguard your test setup for the future. The N8700 is fully compliant with the LXI Class C specification.

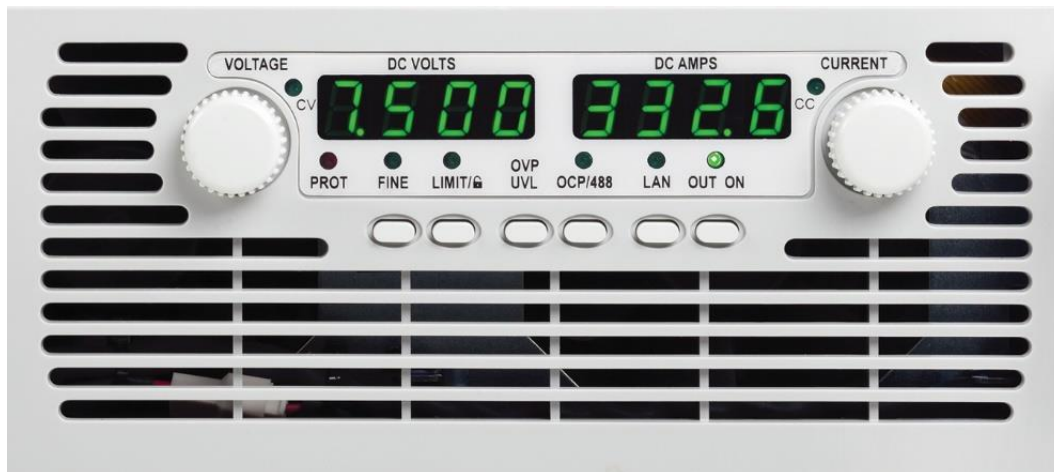

Figure 1. Front panel control knobs and buttons make the N8700 easy to use in a system and on the bench



Figure 2. The N8700's standard LAN (LXI C), USB 2.0 and GPIB interfaces enable simple system connections

Remote access and control

The built-in Web server provides remote access and control of the instrument via a standard browser such as Microsoft Internet Explorer or Mozilla Firefox. This control goes above and beyond the LXI specification, giving users the ability to monitor and control the instrument from anywhere. Using the Web browser, you can set up, monitor and operate the N8700 remotely.

Easy system integration and configuration

To simplify system development, the N8700 comes standard with IVI-COM drivers. The N8700 supports the easy-to-use SCPI (Standard Commands for Programmable Instruments).

Flexible configuration: connect multiple units in parallel or series

Should you need greater output power, the N8700 series power supplies give you the flexibility to connect in parallel up to four identical units (same model number) for greater output current or connect two identical units (same model number) in series for greater output voltage (see output terminal isolation information).

Analog programming and monitoring

The output voltage and current can be programmed from zero to full scale by either an analog voltage 0 to 5 V or 0 to 10 V or by resistance of 0 to 5 k Ω or 0 to 10 k Ω .

Flexible AC input voltage options

The N8700 models offer flexible AC input voltage options. Every N8700 model can be purchased with either a 208 V 3-phase or 400 V 3-phase voltage input option. The 3.3 kW models have the additional option of a 230 V single-phase AC input voltage. Choose the one that best fits your operating environment. They also provide power factor correction.

Please choose carefully the AC input voltage option for your N8700 power supply. The AC input voltage cannot be changed without returning the unit to Keysight and placing a new order.

Rack mounting

The rack mount ears and handles are provided standard with every unit. In addition, the N5740A rack mount slide kit makes it easy to integrate an N8700 into a test rack by providing all the necessary hardware to rack mount an N8700 series power supply in only 2 U of rack space. The N5740A rack mount slide kit is the same kit used with the N5700 series.

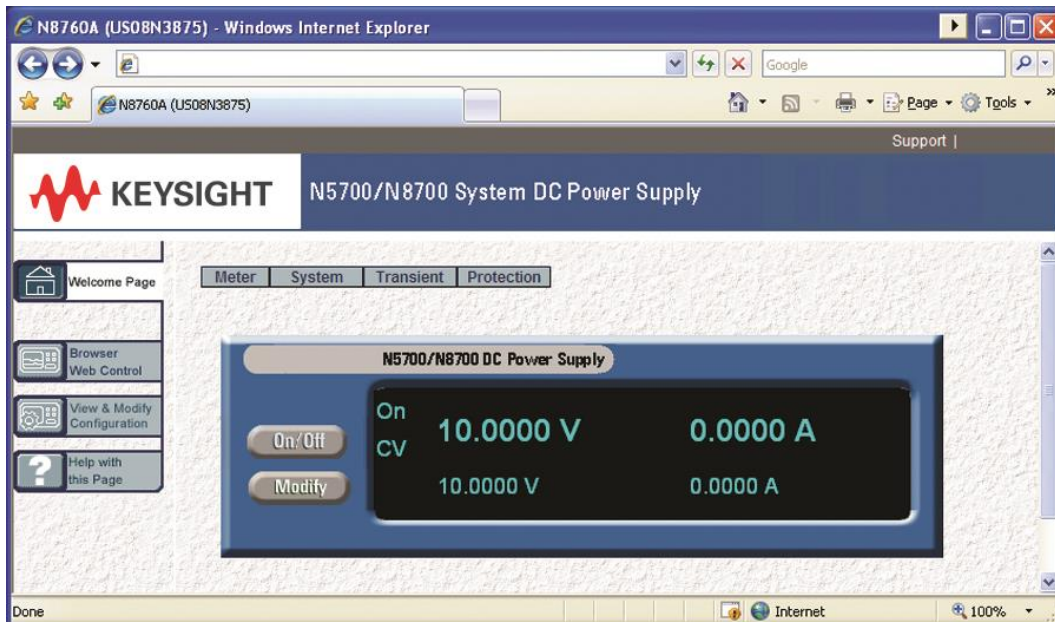

Figure 3. N8700 series web graphical user interface for remote access and control of the power supply

Table 1. Performance specifications, N8731A – N8736A

	N8731A	N8732A	N8733A	N8734A	N8735A	N8736A
DC output ratings						
Voltage ¹	8 V	10 V	15 V	20 V	30 V	40 V
Current ²	400 A	330 A	220 A	165 A	110 A	85 A
Power	3200 W	3300 W	3300 W	3300 W	3300 W	3400 W
Output ripple and noise						
CV _{p-p} ³	60 mV	60 mV	60 mV	60 mV	60 mV	60 mV
CV _{rms} ⁴	8 mV	8 mV	8 mV	8 mV	8 mV	8 mV
Load effect						
CV load regulation ⁵	6.2 mV	6.5 mV	7.25 mV	8 mV	9.5 mV	11 mV
CC load regulation ⁶	85 mA	71 mA	49 mA	38 mA	27 mA	22 mA
Source effect						
CV line regulation ⁷	2.8 mV	3 mV	3.5 mV	4 mV	5 mV	6 mV
CC line regulation ⁷	42 mA	35 mA	24 mA	18.5 mA	13 mA	10.5 mA
Programming accuracy						
Voltage ¹ 0.05% +	4 mV	5 mV	7.5 mV	10 mV	15 mV	20 mV
Current ^{2,8} 0.1% +	800 mA	660 mA	440 mA	330 mA	220 mA	170 mA
Measurement accuracy						
Voltage 0.1% +	8 mV	10 mV	15 mV	20 mV	30 mV	40 mV
Current ⁸ 0.1% +	1200 mA	990 mA	660 mA	495 mA	330 mA	255 mA
Load transient recovery time						
Time ⁹	<1 ms	<1 ms	<1 ms	<1 ms	<1 ms	<1 ms

¹ Minimum voltage is guaranteed to maximum 0.2% of rated output voltage.

² Minimum current is guaranteed to maximum 0.4% of rated output current.

³ 20 MHz

⁴ 5 Hz - 1 MHz

⁵ From no-load to full-load, constant input voltage. Maximum drop in remote sense.

⁶ For load voltage change equal to the unit voltage rating, constant input voltage

⁷ Single-phase and 3-Phase 208 V models: 170–265 VAC, constant load. 3-Phase 400 V models: 342–460 VAC, constant load.

⁸ The constant current programming readback and monitoring accuracy does not include the warm-up and load regulation thermal drift.

⁹ Time for output voltage to recover within 0.5% of its rated output for a load change 10 - 90% of rated output current, local sense.

Table 2. Performance specifications, N8737A – N8742A

	N8737A	N8738A	N8739A	N8740A	N8741A	N8742A
DC output ratings						
Voltage ¹	60 V	80 V	100 V	150 V	300 V	600 V
Current ²	55 A	42 A	33 A	22 A	11 A	5.5 A
Power	3300 W	3360 W	3300 W	3300 W	3300 W	3300 W
Output ripple and noise						
CV _{p-p} ³	60 mV	80 mV	100 mV	100 mV	300 mV	500 mV
CV _{rms} ⁴	8 mV	25 mV	25 mV	25 mV	100 mV	120 mV
Load effect						
CV load regulation ⁵	14 mV	17 mV	20 mV	27.5 mV	50 mV	95 mV
CC load regulation ⁶	16 mA	13.4 mA	11.6 mA	9.4 mA	7.2 mA	6.1 mA
Source effect						
CV line regulation ⁷	8 mV	10 mV	12 mV	17 mV	32 mV	62 mV
CC line regulation ⁷	7.5 mA	6.2 mA	5.3 mA	4.2 mA	3.1 mA	2.6 mA
Programming accuracy						
Voltage 0.05% +	30 mV	40 mV	50 mV	75 mV	150 mV	300 mV
Current 0.1% +	110 mA	84 mA	66 mA	44 mA	22 mA	11 mA
Measurement accuracy						
Voltage 0.1% + ¹	60 mV	80 mV	100 mV	150 mV	300 mV	600 mV
Current 0.1% + ⁸	165 mA	126 mA	99 mA	66 mA	33 mA	16.5 mA
Load transient recovery time						
Time ⁹	<1 ms	<1 ms	<1 ms	<2 ms	<2 ms	<2 ms

Table 3. Supplemental Characteristics

	N8731A	N8732A	N8733A	N8734A	N8735A	N8736A
Output response time						
Up-prog response time ¹⁰	80 ms	80 ms	80 ms	80 ms	80 ms	80 ms
Down-prog response time Full-load ¹⁰	20 ms	100 ms	100 ms	100 ms	160 ms	160 ms
Down-prog response time No-load ¹¹	500 ms	600 ms	700 ms	800 ms	900 ms	1000 ms
Command response time (add this to the output response time to obtain the total programming time)						
	100 ms (typical)	100 ms (typical)	100 ms (typical)	100 ms (typical)	100 ms (typical)	100 ms (typical)
Remote sense compensation						
	2 V	2 V	2 V	2 V	5 V	5 V
Over-voltage protection						
Range	0.5-10 V	0.5-12 V	1-18 V	1-24 V	2-36 V	2-44 V
Output ripple and noise						
CC rms ¹²	1300 mA	1200 mA	880 mA	660 mA	300 mA	200 mA
Programming resolution/measurement resolution						
Voltage	0.96 mV	1.2 mV	1.8 mV	2.4 mV	3.6 mV	4.8 mV
Current	48 mA	39.6 mA	26.4 mA	19.8 mA	13.2 mA	10.2 mA
Front panel display accuracy (4 digits; ± 1 count)						
Voltage	40 mV	50 mV	75 mV	100 mV	150 mV	200 mV
Current	2000 mA	1650 mA	1100 mA	825 mA	550 mA	425 mA
Temperature stability (over 8 hours, after a 30 minute warm-up, with constant line, load, and temperature)						
Voltage	4 mV	5 mV	7.5 mV	10 mV	15 mV	20 mV
Current	200 mA	165 mA	110 mA	82.5 mA	55 mA	42.5 mA
Temperature coefficient (after a 30 minute warm-up)						
Voltage (from rated output voltage)	100 PPM/°C	100 PPM/°C	100 PPM/°C	100 PPM/°C	100 PPM/°C	100 PPM/°C
Current (from rated output current)	200 PPM/°C	200 PPM/°C	200 PPM/°C	200 PPM/°C	200 PPM/°C	200 PPM/°C

¹⁰ From 10% to 90% or 90% to 10% of rated output voltage, with rated, resistive load.

¹¹ From 90% to 10% of rated output voltage.

¹² For 8 V - 15 V models the ripple is measured from 2 V to rated output voltage and rated output current. For other models, the ripple is measured at 10 - 100% of rated output voltage and rated output current.

Table 4. Supplemental Characteristics

	N8737A	N8738A	N8739A	N8740A	N8741A	N8742A
Output response time						
Up-prog response time ¹⁰	150 ms	150 ms	150 ms	150 ms	150 ms	250 ms
Down-prog response time Full-load ¹⁰	160 ms	300 ms	300 ms	300 ms	300 ms	500 ms
Down-prog response time No-load ¹¹	1100 ms	1200 ms	1500 ms	2000 ms	3500 ms	4000 ms
Command response time (add this to the output response time to obtain the total programming time)						
	100 ms (typical)	100 ms (typical)	100 ms (typical)	100 ms (typical)	100 ms (typical)	100 ms (typical)
Remote sense compensation						
	5 V	5 V	5 V	5 V	5 V	5 V
Over-voltage protection						
Range	5-66 V	5-88 V	5-110 V	5-165 V	5-330 V	5-660 V
Output ripple and noise						
CC rms ¹²	100 mA	80 mA	70 mA	60 mA	20 mA	10 mA
Programming resolution/measurement resolution						
Voltage	7.2 mV	9.6 mV	12 mV	18 mV	36 mV	72 mV
Current	6.6 mA	5 mA	4 mA	2.6 mA	1.3 mA	0.66 mA
Front panel display accuracy (4 digits; ± 1 count)						
Voltage	300 mV	400 mV	500 mV	750 mV	1500 mV	3000 mV
Current	275 mA	210 mA	165 mA	110 mA	55 mA	27.5 mA
Temperature stability (over 8 hours, after a 30 minute warm-up, with constant line, load, and temperature)						
Voltage	30 mV	40 mV	50 mV	75 mV	150 mV	300 mV
Current	27.5 mA	21 mA	16.5 mA	11 mA	5.5 mA	2.8 mA
Temperature coefficient (after a 30 minute warm-up)						
Voltage (from rated output voltage)	100 PPM/°C	100 PPM/°C	100 PPM/°C	100 PPM/°C	100 PPM/°C	100 PPM/°C
Current (from rated output current)	200 PPM/°C	200 PPM/°C	200 PPM/°C	200 PPM/°C	200 PPM/°C	200 PPM/°C

Table 5. Performance Specifications

	N8754A	N8755A	N8756A	N8757A	N8758A
DC output ratings					
Voltage ¹	20 V	30 V	40 V	60 V	80 V
Current ²	250 A	170 A	125 A	85 A	65 A
Power	5000 W	5100 W	5000 W	5100 W	5200 W
Output ripple and noise					
CV _{p-p} ³	75 mV	75 mV	75 mV	75 mV	100 mV
CV _{rms} ⁴	10 mV	10 mV	10 mV	10 mV	15 mV
Load effect					
CV load regulation ⁵	8 mV	9.5 mV	11 mV	14 mV	17 mV
CC load regulation ⁶	250 mA	170 mA	125 mA	85 mA	65 mA
Source effect					
CV line regulation ⁷	2 mV	3 mV	4 mV	6 mV	8 mV
CC line regulation ⁷	125 mA	85 mA	62.5 mA	42.5 mA	32.5 mA
Programming accuracy					
Voltage ¹ 0.025% +	15 mV	22.5 mV	30 mV	45 mV	60 mV
Current ^{2,8} 0.1% +	750 mA	510 mA	375 mA	255 mA	195 mA
Measurement accuracy					
Voltage 0.025% +	25 mV	37.5 mV	50 mV	75 mV	100 mV
Current ^{2,8} 0.1% +	750 mA	510 mA	375 mA	255 mA	195 mA
Load transient recovery time					
Time ⁹	<1 ms	<1 ms	<1 ms	<1 ms	<1 ms

Table 6. Performance Specifications

	N8759A	N8760A	N8761A	N8762A
DC output ratings				
Voltage ¹	100 V	150 V	300 V	600 V
Current ²	50 A	34 A	17 A	8.5 A
Power	5000 W	5100 W	5100 W	5100 W
Output ripple and noise				
CV _{p-p} ³	100 mV	120 mV	300 mV	500 mV
CV _{rms} ⁴	15 mV	25 mV	60 mV	120 mV
Load effect				
CV load regulation ⁵	20 mV	27.5 mV	50 mV	95 mV
CC load regulation ⁶	50 mA	34 mA	17 mA	8.5 mA
Source effect				
CV line regulation ⁷	10 mV	15 mV	30 mV	60 mV
CC line regulation ⁷	25 mA	17 mA	8.5 mA	4.3 mA
Programming accuracy				
Voltage ¹ 0.025% +	75 mV	112.5 mV	225 mV	450 mV
Current ^{2, 8} 0.1% +	150 mA	102 mA	51 mA	25.5 mA
Measurement accuracy				
Voltage 0.025% +	125 mV	187.5 mV	375 mV	750 mV
Current ⁸ 0.1% +	150 mA	102 mA	51 mA	25.5 mA
Load transient recovery time				
Time ^{Error! Bookmark not defined.9}	<1 ms	<2 ms	<2 ms	<2 ms

Table 7. Supplemental Characteristics

	N8754A	N8755A	N8756A	N8757A	N8758A
Output response time					
Up-prog response time ¹⁰	30 ms	30 ms	30 ms	50 ms	50 ms
Down-prog response time Full-load ¹⁰	50 ms	80 ms	80 ms	80 ms	100 ms
Down-prog response time No-load ¹¹	700 ms	800 ms	900 ms	1000 ms	1200 ms
Command response time (add this to the output response time to obtain the total programming time)					
	100 ms (typical)	100 ms (typical)	100 ms (typical)	100 ms (typical)	100 ms (typical)
Remote sense compensation					
	2 V	5 V	5 V	5 V	5 V
Over-voltage protection					
Range	1-24 V	2-36 V	2-44 V	5-66 V	5-88 V
Output ripple and noise					
CC rms ¹²	1000 mA	460 mA	300 mA	150 mA	120 mA
Programming resolution/measurement resolution					
Voltage	2.4 mV	3.6 mV	4.8 mV	7.2 mV	9.6 mV
Current	30 mA	20.4 mA	15 mA	10.2 mA	7.8 mA
Front panel display accuracy (4 digits; ± 1 count)					
Voltage	100 mV	150 mV	200 mV	300 mV	400 mV
Current	1250 mA	850 mA	625 mA	425 mA	325 mA
Temperature stability (over 8 hours, after a 30 minute warm-up, with constant line, load, and temperature)					
Voltage	10 mV	15 mV	20 mV	30 mV	40 mV
Current	125 mA	85 mA	62.5 mA	42.5 mA	32.5 mA
Temperature coefficient					
Voltage (from rated output voltage)	100 PPM/°C	100 PPM/°C	100 PPM/°C	100 PPM/°C	100 PPM/°C
Current (from rated output current)	100 PPM/°C	100 PPM/°C	100 PPM/°C	100 PPM/°C	100 PPM/°C

Table 8. Supplemental Characteristics

	N8759A	N8760A	N8761A	N8762A
Output response time				
Up-prog response time ¹⁰	50 ms	50 ms	50 ms	100 ms
Down-prog response time Full-load ¹⁰	100 ms	100 ms	100 ms	200 ms
Down-prog response time No-load ¹¹	1500 ms	2000 ms	2500 ms	3000 ms
Command response time (add this to the output response time to obtain the total programming time)				
	100 ms (typical)	100 ms (typical)	100 ms (typical)	100 ms (typical)
Remote sense compensation				
	5 V	5 V	5 V	5 V
Over-voltage protection				
Range	5-110 V	5-165 V	5-330 V	5-660 V
Output ripple and noise				
CC rms ¹²	100 mA	90 mA	30 mA	15 mA
Programming resolution/Measurement resolution				
Voltage	12 mV	18 mV	36 mV	72 mV
Current	6 mA	4.1 mA	2 mA	1 mA
Front panel display accuracy (4 digits; ± 1 count)				
Voltage	500 mV	750 mV	1500 mV	3000 mV
Current	250 mA	170 mA	85 mA	42.5 mA
Temperature stability (over 8 hours, after a 30 minute warm-up, with constant line, load, and temperature)				
Voltage	50 mV	75 mV	150 mV	300 mV
Current	25 mA	17 mA	8.5 mA	4.3 mA
Temperature coefficient (after a 30 minute warm-up)				
Voltage (from rated output voltage)	100 PPM/°C	100 PPM/°C	100 PPM/°C	100 PPM/°C
Current (from rated output current)	100 PPM/°C	100 PPM/°C	100 PPM/°C	100 PPM/°C

Table 9. Supplemental Characteristics

Analog programming and monitoring	All Models (unless otherwise specified)
V _{out} voltage programming	0-100%, 0-5 V or 0-10 V, user selectable. Accuracy and linearity: ±0.5% of rated V _{out} .
I _{out} voltage programming ¹³	0-100%, 0-5 V or 0-10 V, user selectable. Accuracy and linearity: ±1% of rated I _{out} .
V _{out} resistor programming	0-100%, 0-5/10 Kohm full scale, user selectable. Accuracy and linearity: ±1% of rated V _{out} .
I _{out} resistor programming ¹³	0-100%, 0-5/10 Kohm full scale, user selectable. Accuracy and linearity: ±1.5% of rated I _{out} .
On/Off control (rear panel)	Controlled by voltage: 0-0.6 V/2-15 V, or dry contact, user selectable logic.
Output current monitor ¹³	0-5 V or 0-10 V, user selectable, Accuracy: ±1%.
Output voltage monitor	0-5 V or 0-10 V, user selectable, Accuracy: ±1%.
Power supply OK signal	TTL high (4-5 V) = OK; 0 V = Fail; 500 ohm series resistance.
CV/CC Indicator	3.3 kW: CV = TTL high (4-5 V) (source current: 10 mA); CC = TTL low (0-0.6 V) (sink current = 10 mA)
Enable/disable	Dry contact. Open: off, Short: on. Max. voltage at terminal = 6 V
Series and parallel capability	
Parallel operation	Up to 4 identical units (same model number) can be connected in master/slave mode with single-wire current balancing
Series operation	Up to 2 identical units (same model number) can be connected using external protection diodes (see Output Terminal Isolation)
Savable states	
In volatile memory	16 (in memory locations 0-15)
Interface capabilities	
GPIB	SCPI - 1993, IEEE 488.2 compliant interface
LXI Compliance	Class C (only applies to units with the LXI label on the front panel)
USB 2.0	Requires Keysight I/O Library version M.01.01 and up, or 14.0 and up
10/100 LAN	Requires Keysight I/O Library version L.01.01 and up, or 14.0 and up

¹³ The constant current programming readback and monitoring accuracy does not include the warm-up and load regulation thermal drift.

Analog programming and monitoring		All Models (unless otherwise specified)
Environmental conditions		
Environment	Indoor use, installation category II (AC input), pollution degree 2	
Operating temperature	0°C to 40°C @ 100% load	
Storage temperature	–20°C to 70°C	
Operating humidity	30% to 90% relative humidity (no condensation)	
Storage humidity	10% to 95% relative humidity (no condensation)	
Altitude	<ul style="list-style-type: none"> • Up to 3000 meters. • Above 2000 m, derate the output current by 2%/100 m and derate the maximum ambient temperature by 1°C/100 m. 	
Built-in Web server	Requires Internet Explorer 5+ or Netscape 6.2+	

Table 10. Supplemental Characteristics

Dimensions	All Models (unless otherwise specified)
(excluding connectors and handles)	Height: 88 mm (3.46 in); Width: 423 mm (16.65 in); Depth: 442.5 mm (17.42 in)
Weight	
	3.3 kW: 13 kg (28.6 lbs.); 5 kW: 16 kg (35.2 lbs.)
Regulatory compliance	
EMC	<ul style="list-style-type: none"> Complies with the European EMC directive 89/336/EEC for Class A test and measurement products. Complies with the Australian standard and carries the C-Tick mark. This ISM device complies with Canadian ICES-001. Cet appareil ISM est conforme à la norme NMB-001 du Canada. Electrostatic discharges >1 kV near the I/O connectors may cause the unit to reset and require operator intervention.
Safety	<ul style="list-style-type: none"> Complies with the European Low Voltage Directive 73/23/EEC and carries the CE-marking. Complies with the US and Canadian safety standards for test and measurement products. Any LEDs used in this product are Class 1 LEDs as per IEC 825-1
Acoustic noise declaration	
	<ul style="list-style-type: none"> Statements provided to comply with requirements of the German Sound Emission Directive, from 18 January 1991: Sound Pressure Lp <70 dB(A), *At Operator Position, *Normal Operation, *According to EN 27779 (Type Test). Schalldruckpegel Lp <70 dB(A) *Am Arbeitsplatz, *Normaler Betrieb, *Nach EN 27779 (Typprüfung).
Output terminal isolation	
8 V to 60 V units	<ul style="list-style-type: none"> No output terminal may be more than ± 60 VDC from any other terminal or chassis ground.
80 V to 600 V units	<ul style="list-style-type: none"> No positive output terminal may be more than ± 600 VDC from any other terminal or chassis ground. No negative output terminal may be more than ± 400 VDC from any other terminal or chassis ground.

Table 11. Supplemental Characteristics

AC Input	All Models (unless otherwise specified)	
Nominal input	230 VAC single-phase option ¹⁴	190 - 240 VAC; 50/60 Hz
	208 VAC 3-phase option	190 - 240 VAC; 50/60 Hz
	400 VAC 3-phase option	380 - 415 VAC; 50/60 Hz
Input current	230 VAC single-phase option ¹⁴	23 - 24 A Max @ 100% load
	208 VAC 3-phase option	3.3 kW models: 13.6 - 14.5 A Max @ 100% load 5 kW models: 21-22 A max @ 100% load
	400 VAC 3-phase option	3.3 kW models: 6.8 - 7.2 A Max @ 100% load 5 kW models: 10.5 - 12 A Max @ 100% load
Input range	230 VAC single-phase option ¹⁴	170 - 265 VAC; 47 - 63 Hz
	208 VAC 3-phase option	170 - 265 VAC; 47 - 63 Hz
	400 VAC 3-phase option	342 - 460 VAC; 47 - 63 Hz
Input VA	3.3 kW models	4000 VA
	5 kW models	5800 VA
Power factor	230 VAC single-phase option ¹⁴	0.99 at nominal input and rated output power
	208 & 400 VAC 3-phase options	<ul style="list-style-type: none"> • 3.3 kW models: 0.95 at nominal input and rated output power • 5 kW models: 0.94 at nominal input and rated output power
Efficiency	3.3 kW models	82% - 88%
	5 kW models	83% - 88%
Inrush current	230 VAC single-phase option ¹⁴	< 50 A
	208 VAC 3-phase option	< 50 A
	400 VAC 3-phase option	< 20 A

¹⁴ The constant current programming readback and monitoring accuracy does not include the warm-up and load regulation thermal drift.

Outline Diagram

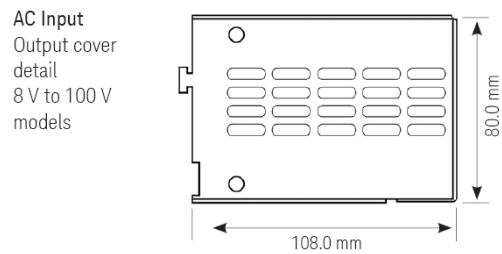
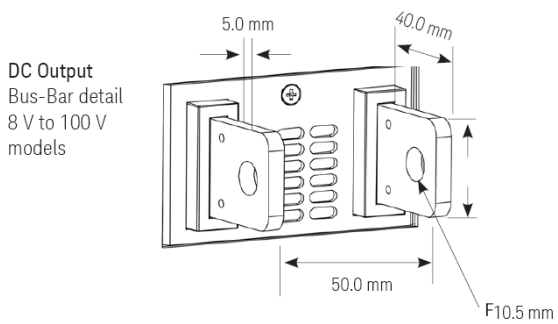
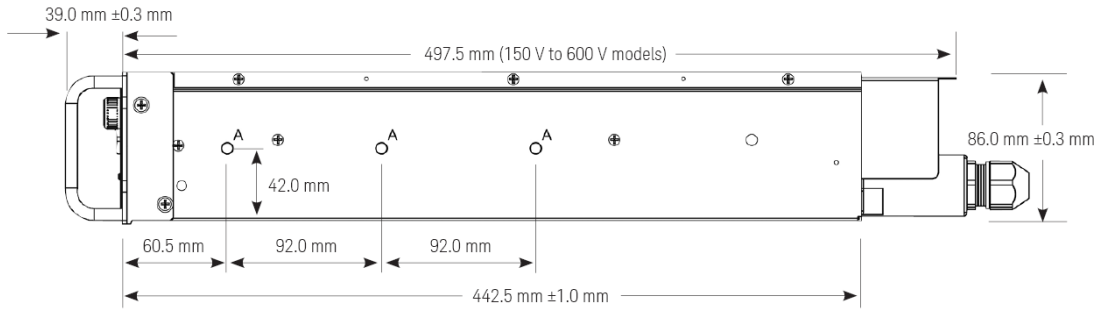
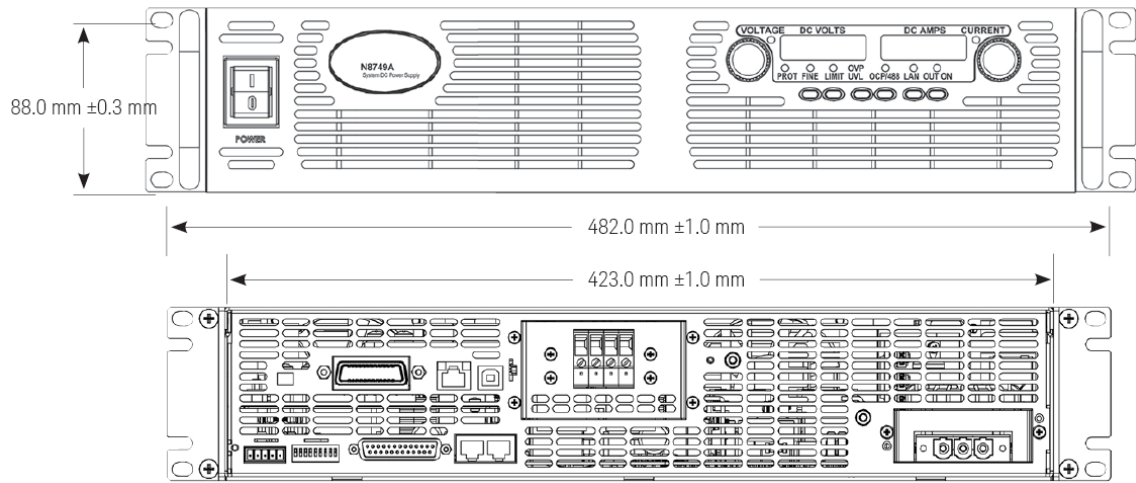

Front and Rear Panel Detail

Front panel (All models)

Air flows through the front and out the rear.

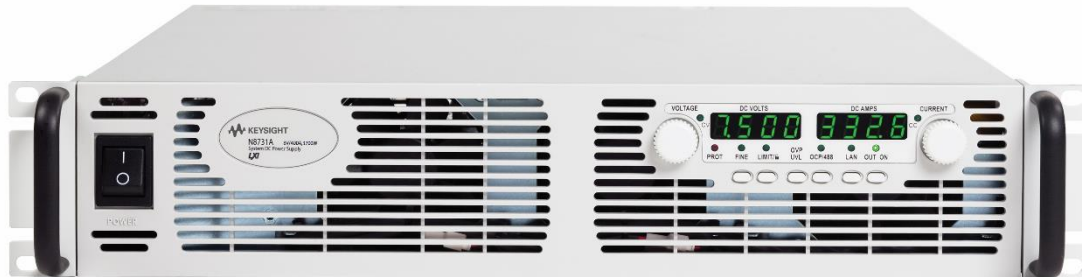

Rear panel with busbars

8 V to 100 V models (shown with 230 V single-phase AC input voltage option, available on 3.3 kW models only)



Rear panel with wire clamp connectors

150 V to 600 V models (shown with 400 V 3-phase AC option, available on all models)



Ordering Information

Keysight N8700 Series

Model	Voltage (V)	Current (A)	Max Power (W)	Series
N8731A	8 V	400 A	3200 W	3.3 kW
N8732A	10 V	330 A	3300 W	3.3 kW
N8733A	15 V	220 A	3300 W	3.3 kW
N8734A	20 V	165 A	3300 W	3.3 kW
N8735A	30 V	110 A	3300 W	3.3 kW
N8736A	40 V	85 A	3400 W	3.3 kW
N8737A	60 V	55 A	3300 W	3.3 kW
N8738A	80 V	42 A	3360 W	3.3 kW
N8739A	100 V	33 A	3300 W	3.3 kW
N8740A	150 V	22 A	3300 W	3.3 kW
N8741A	300 V	11 A	3300 W	3.3 kW
N8742A	600 V	5.5 A	3300 W	3.3 kW
N8754A	20 V	250 A	5000 W	5 kW
N8755A	30 V	170 A	5100 W	5 kW
N8756A	40 V	125 A	5000 W	5 kW
N8757A	60 V	85 A	5100 W	5 kW
N8758A	80 V	65 A	5200 W	5 kW
N8759A	100 V	50 A	5000 W	5 kW
N8760A	150 V	34 A	5100 W	5 kW
N8761A	300 V	17 A	5100 W	5 kW
N8762A	600 V	8.5 A	5100 W	5 kW

Options

All Models (unless otherwise specified)	
Opt 861	Unterminated line cord for 208 V 3-phase AC input voltage (Option 208)
Opt 862	Unterminated line cord for 400 V 3-phase AC input voltage (Option 400)
Opt 831 ¹⁴	Unterminated line cord for 230 V single-phase AC input voltage (Option 230)
Opt 832 ¹⁴	Unterminated, harmonized line cord for Europe for 230 V single-phase AC input voltage (Option 230)
Opt 208	190-240 V, 3-phase AC, 50/60 Hz input (use with line cord Opt 861)
Opt 400	380-415 V, 3-phase AC, 50/60 Hz input (use with line cord Opt 862)
Opt 230 ¹⁴ <small>Error! Bookmark not defined.</small>	190-240 V, single-phase AC, 50/60 Hz input (use with line cord Opt 831 or 832)

Accessories

N5740A	Rack mount slide kit (required for rack mounting; standard system rack-mounting hardware will not work)
--------	---

Learn more at: www.keysight.com

For more information on Keysight Technologies' products, applications or services, please contact your local Keysight office. The complete list is available at: www.keysight.com/find/contactus



Данный компонент на территории Российской Федерации

Вы можете приобрести в компании MosChip.

Для оперативного оформления запроса Вам необходимо перейти по данной ссылке:

<http://moschip.ru/get-element>

Вы можете разместить у нас заказ для любого Вашего проекта, будь то серийное производство или разработка единичного прибора.

В нашем ассортименте представлены ведущие мировые производители активных и пассивных электронных компонентов.

Нашей специализацией является поставка электронной компонентной базы двойного назначения, продукции таких производителей как XILINX, Intel (ex.ALTERA), Vicor, Microchip, Texas Instruments, Analog Devices, Mini-Circuits, Amphenol, Glenair.

Сотрудничество с глобальными дистрибьюторами электронных компонентов, предоставляет возможность заказывать и получать с международных складов практически любой перечень компонентов в оптимальные для Вас сроки.

На всех этапах разработки и производства наши партнеры могут получить квалифицированную поддержку опытных инженеров.

Система менеджмента качества компании отвечает требованиям в соответствии с ГОСТ Р ИСО 9001, ГОСТ РВ 0015-002 и ЭС РД 009

Офис по работе с юридическими лицами:

105318, г.Москва, ул.Щербаковская д.3, офис 1107, 1118, ДЦ «Щербаковский»

Телефон: +7 495 668-12-70 (многоканальный)

Факс: +7 495 668-12-70 (доб.304)

E-mail: info@moschip.ru

Skype отдела продаж:

moschip.ru

moschip.ru_4

moschip.ru_6

moschip.ru_9