

VSC3304

VITESSE®

8.5 Gbps 4 × 4 Crosspoint Switch



BLOCK DIAGRAM:

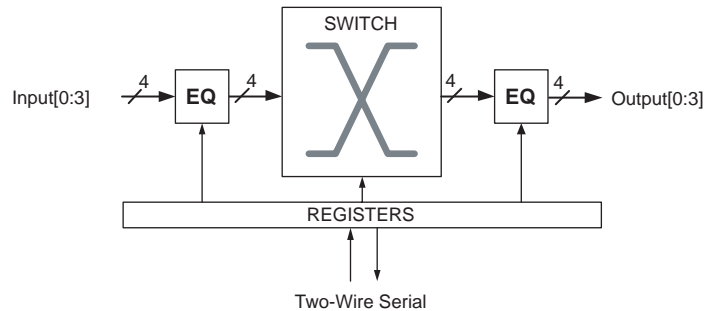

FEATURES:

- ▶ 8.5 Gbps non-return-to-zero (NRZ) data bandwidth
- ▶ Fully non-blocking and multicasting switch core with per-pin signal inversion capability
- ▶ Multiple time-constant programmable input and output equalization
- ▶ Wide equalization adjustment range
- ▶ Fully asynchronous operation with <1 ns latency
- ▶ Reconfigurable Input/Output (I/O) capability
- ▶ LOS detection and forwarding
- ▶ Small 7 mm × 7 mm BGA with 1.0 mm pin pitch

BENEFITS:

- ▶ Transparent support for virtually all data rates and protocols
- ▶ Allows complete flexibility in routing and distributing signals
- ▶ Compensates for multiple impairments in a signal path
- ▶ Supports all types of interconnect media: PCB, backplanes, and cable
- ▶ No adjustments based on data rate or reference clock required
- ▶ Customize the I/O to the application
- ▶ OOB forwarding for protocols like SAS and SATA
- ▶ Convenient size and pin spacing for signal routing flexibility

APPLICATIONS:

- ▶ Wideband signal switching and clean-up
- ▶ Line driver or receiver
- ▶ Backplane signal fanout, driver, or receiver
- ▶ Copper cable driver or receiver
- ▶ PCB signal enhancement
- ▶ High-speed signal conditioner

VSC3304

8.5 Gbps 4 × 4 Crosspoint Switch

GENERAL DESCRIPTION:



The VSC3304 is a 4-port 8.5 Gbps asynchronous switch with advanced signal equalization designed for high-speed serial backplanes and cable interconnect applications. VSC3304 switches allow multicast, loopback, and reconfigurable Input/Output (I/O) capability, allowing for great flexibility in allocating and routing signals in a broad range of applications. The VSC3304 includes dual time-constant equalization, which significantly reduces jitter associated with driving multigigabit signals across backplanes and cables.

Using a fully asynchronous architecture allows any data rate or protocol on any channel without the need for an external reference clock. This gives the VSC3304 wire-like interoperability in virtually any application that uses binary signaling.

The VSC3304 can also be used as a buffer that simplifies and enhances the design of high-speed signal paths by providing signal equalization at both inputs and outputs to reduce or reverse signal degradation due to transmission line effects.

VSC3304 ports may be configured as either inputs or outputs without restriction. This design provides the flexibility of using the device as a standard 4 × 4 crosspoint, or any ratio from 1 × 7 to 7 × 1. This unique feature allows full I/O utilization in any application that translates to a significant reduction in chip count.

Featuring programmable input signal equalization and output pre-emphasis, each with multiple time constants, the VSC3304 is also ideal for countering signal degradation over a wide variety of transmission media types and lengths.

Typical power consumption for the device is 160 mW per active channel, and unused channels may be de-activated to save the power associated with those ports. The output drivers for the VSC3304 also feature a wide supply voltage range, from 1.8 V to 3.3 V, that allows flexibility in matching the output swing to the application requirements.

The VSC3304 has a loss of signal (LOS) detector with programmable thresholds on every input port. LOS forwarding can be enabled for each of the outputs, which will cause the outputs to be squelched in response to a LOS detect at the corresponding input, thereby propagating signal envelopes through the switch.

VSC3304 programming is through a standard two-wire serial interface. The interface address can be hardwired through static pins or through a proprietary two-pin interface that allows for address assignment after power-up.

For more information about signal integrity solutions, visit the Vitesse Web site at www.vitesse.com/SI.

BACKPLANE APPLICATION:

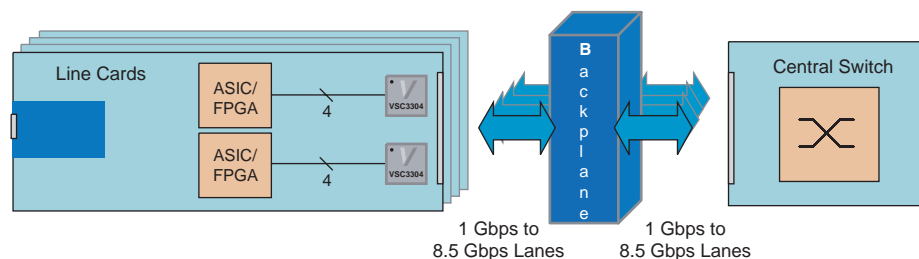

SPECIFICATIONS:

- ▶ 8.5 Gbps non-return-to-zero (NRZ) per-channel data rate
- ▶ 2.5 V core; 1.8 V, 2.5 V, and 3.3 V high-speed I/O
- ▶ 1.2 W at 3.3 V, or 0.9 W at 2.5 V, or 0.7 W at 1.8 V

Trademarks™

Vitesse, ASIC-Friendly, FibreTimer, TimeStream, Snoop Loop, Super FEC, FOCUSConnect, Meigs-II, Meigs-IIIe, Lansing, Campbell-I, Barrington, PaceMaker, HOVCAT48, HOVCAT48e, HOVCAT192, HOVCAT192e, Micro PHY, FOCUS32, FOCUS16, IQ2200, NexSAS, VersaCAT, GigaStream, HawX, SparX, StaX, VstaX, SimpliPHY, VeriPHY, ActiPHY, XFP PRO, SFP PRO, Smart-LINK, OctalMAC, EQ Technology are trademarks in the United States and/or other jurisdictions of Vitesse Semiconductor Corporation. All other trademarks or registered trademarks mentioned herein are the property of their respective holders.

Copyright © 2006–2007

Vitesse Semiconductor Corporation ("Vitesse") retains the right to make changes to its products or specifications to improve performance, reliability or manufacturability. All information in this document, including descriptions of features, functions, performance, technical specifications and availability, is subject to change without notice at any time. While the information furnished herein is held to be accurate and reliable, no responsibility will be assumed by Vitesse for its use. Furthermore, the information contained herein does not convey to the purchaser of microelectronic devices any license under the patent right of any manufacturer.

741 Calle Plano
Camarillo, CA 93012, USA
Tel: +1 805.388.3700
Fax: +1 805.987.5896
www.vitesse.com
sales@vitesse.com

Данный компонент на территории Российской Федерации

Вы можете приобрести в компании MosChip.

Для оперативного оформления запроса Вам необходимо перейти по данной ссылке:

<http://moschip.ru/get-element>

Вы можете разместить у нас заказ для любого Вашего проекта, будь то серийное производство или разработка единичного прибора.

В нашем ассортименте представлены ведущие мировые производители активных и пассивных электронных компонентов.

Нашей специализацией является поставка электронной компонентной базы двойного назначения, продукции таких производителей как XILINX, Intel (ex.ALTERA), Vicor, Microchip, Texas Instruments, Analog Devices, Mini-Circuits, Amphenol, Glenair.

Сотрудничество с глобальными дистрибьюторами электронных компонентов, предоставляет возможность заказывать и получать с международных складов практически любой перечень компонентов в оптимальные для Вас сроки.

На всех этапах разработки и производства наши партнеры могут получить квалифицированную поддержку опытных инженеров.

Система менеджмента качества компании отвечает требованиям в соответствии с ГОСТ Р ИСО 9001, ГОСТ РВ 0015-002 и ЭС РД 009

Офис по работе с юридическими лицами:

105318, г.Москва, ул.Щербаковская д.3, офис 1107, 1118, ДЦ «Щербаковский»

Телефон: +7 495 668-12-70 (многоканальный)

Факс: +7 495 668-12-70 (доб.304)

E-mail: info@moschip.ru

Skype отдела продаж:

moschip.ru

moschip.ru_4

moschip.ru_6

moschip.ru_9