

HEXFET® Power MOSFET

| | | |
|---|------------|-----------|
| V_{DS} | 200 | V |
| $R_{DS(on) max}$ (@ $V_{GS} = 10V$) | 55 | mΩ |
| Q_g (typical) | 36 | nC |
| R_G (typical) | 1.9 | Ω |
| I_D (@ $T_{c(Bottom)} = 25°C$) | 34 | A |

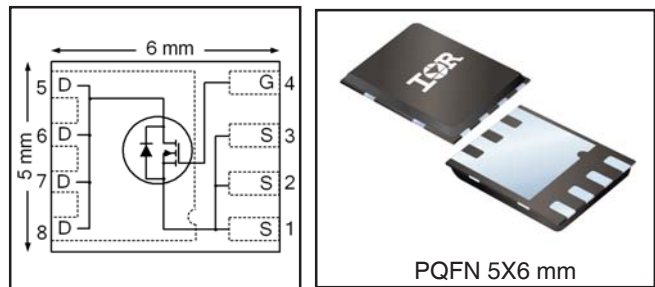

Applications

- Secondary Side Synchronous Rectification
- Inverters for DC Motors
- DC-DC Brick Applications
- Boost Converters

Features and Benefits

Features

| |
|--|
| Low $R_{DS(on)}$ |
| Low Thermal Resistance to PCB ($\leq 0.8°C/W$) |
| 100% R_g tested |
| Low Profile (≤ 0.9 mm) |
| Industry-Standard Pinout |
| Compatible with Existing Surface Mount Techniques |
| RoHS Compliant Containing no Lead, no Bromide and no Halogen |
| MSL1, Industrial Qualification |

results in
 ⇒

Benefits

| |
|-----------------------------------|
| Lower Conduction Losses |
| Enable better thermal dissipation |
| Increased Reliability |
| Increased Power Density |
| Multi-Vendor Compatibility |
| Easier Manufacturing |
| Environmentally Friendlier |
| Increased Reliability |

| Orderable part number | Package Type | Standard Pack | | Note |
|-----------------------|----------------|---------------|----------|-----------------|
| | | Form | Quantity | |
| IRFH5020TRPbF | PQFN 5mm x 6mm | Tape and Reel | 4000 | |
| IRFH5020TR2PbF | PQFN 5mm x 6mm | Tape and Reel | 400 | EOL notice #259 |

Absolute Maximum Ratings

| | Parameter | Max. | Units |
|-------------------------------|--|--------------|-------|
| V_{DS} | Drain-to-Source Voltage | 200 | V |
| V_{GS} | Gate-to-Source Voltage | ± 20 | |
| $I_D @ T_A = 25°C$ | Continuous Drain Current, $V_{GS} @ 10V$ | 5.1 | A |
| $I_D @ T_A = 70°C$ | Continuous Drain Current, $V_{GS} @ 10V$ | 4.1 | |
| $I_D @ T_{C(Bottom)} = 25°C$ | Continuous Drain Current, $V_{GS} @ 10V$ | 34 | |
| $I_D @ T_{C(Bottom)} = 100°C$ | Continuous Drain Current, $V_{GS} @ 10V$ | 21 | |
| $I_D @ T_{C(Top)} = 25°C$ | Continuous Drain Current, $V_{GS} @ 10V$ | 7.8 | |
| $I_D @ T_{C(Top)} = 100°C$ | Continuous Drain Current, $V_{GS} @ 10V$ | 4.9 | |
| I_{DM} | Pulsed Drain Current ① | 63 | |
| $P_D @ T_A = 25°C$ | Power Dissipation ② | 3.6 | W |
| $P_D @ T_{C(Top)} = 25°C$ | Power Dissipation ④ | 8.3 | |
| | Linear Derating Factor ④ | 0.07 | W/°C |
| T_J | Operating Junction and | -55 to + 150 | °C |
| T_{STG} | Storage Temperature Range | | |

Notes ① through ⑤ are on page 9

Static @ T_J = 25°C (unless otherwise specified)

| | Parameter | Min. | Typ. | Max. | Units | Conditions |
|-------------------------------------|---|------|------|------|-------|---|
| BV _{DSS} | Drain-to-Source Breakdown Voltage | 200 | — | — | V | V _{GS} = 0V, I _D = 250μA |
| ΔBV _{DSS} /ΔT _J | Breakdown Voltage Temp. Coefficient | — | 0.22 | — | V/°C | Reference to 25°C, I _D = 1mA |
| R _{DS(on)} | Static Drain-to-Source On-Resistance | — | 47 | 55 | mΩ | V _{GS} = 10V, I _D = 7.5A ③ |
| V _{GS(th)} | Gate Threshold Voltage | 3.0 | — | 5.0 | V | V _{DS} = V _{GS} , I _D = 150μA |
| ΔV _{GS(th)} | Gate Threshold Voltage Coefficient | — | -12 | — | mV/°C | |
| I _{DSS} | Drain-to-Source Leakage Current | — | — | 20 | μA | V _{DS} = 200V, V _{GS} = 0V |
| | | — | — | 1.0 | mA | V _{DS} = 200V, V _{GS} = 0V, T _J = 125°C |
| I _{GSS} | Gate-to-Source Forward Leakage | — | — | 100 | nA | V _{GS} = 20V |
| | Gate-to-Source Reverse Leakage | — | — | -100 | nA | V _{GS} = -20V |
| gfs | Forward Transconductance | 18 | — | — | S | V _{DS} = 50V, I _D = 7.5A |
| Q _g | Total Gate Charge | — | 36 | 54 | nC | V _{DS} = 100V V _{GS} = 10V I _D = 7.5A See Fig.17 & 18 |
| Q _{gs1} | Pre-V _{th} Gate-to-Source Charge | — | 8.6 | — | | |
| Q _{gs2} | Post-V _{th} Gate-to-Source Charge | — | 2.1 | — | | |
| Q _{gd} | Gate-to-Drain Charge | — | 11 | — | | |
| Q _{godr} | Gate Charge Overdrive | — | 14 | — | | |
| Q _{sw} | Switch Charge (Q _{gs2} + Q _{gd}) | — | 13 | — | | |
| Q _{oss} | Output Charge | — | 13 | — | nC | V _{DS} = 16V, V _{GS} = 0V |
| R _G | Gate Resistance | — | 1.9 | — | Ω | |
| t _{d(on)} | Turn-On Delay Time | — | 9.3 | — | ns | V _{DD} = 100V, V _{GS} = 10V I _D = 7.5A R _G = 1.8Ω See Fig.15 |
| t _r | Rise Time | — | 7.7 | — | | |
| t _{d(off)} | Turn-Off Delay Time | — | 21 | — | | |
| t _f | Fall Time | — | 6.0 | — | | |
| C _{iss} | Input Capacitance | — | 2290 | — | pF | V _{GS} = 0V V _{DS} = 100V f = 1.0MHz |
| C _{oss} | Output Capacitance | — | 120 | — | | |
| C _{rss} | Reverse Transfer Capacitance | — | 33 | — | | |

Avalanche Characteristics

| | Parameter | Typ. | Max. | Units |
|-----------------|---------------------------------|------|------|-------|
| E _{AS} | Single Pulse Avalanche Energy ② | — | 320 | mJ |
| I _{AR} | Avalanche Current ① | — | 7.5 | A |

Diode Characteristics

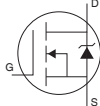
| | Parameter | Min. | Typ. | Max. | Units | Conditions |
|-----------------|--|---|------|------|-------|--|
| I _S | Continuous Source Current (Body Diode) | — | — | 7.5 | A | MOSFET symbol showing the integral reverse p-n junction diode.  |
| I _{SM} | Pulsed Source Current (Body Diode) ① | — | — | 63 | | |
| V _{SD} | Diode Forward Voltage | — | — | 1.3 | V | T _J = 25°C, I _S = 7.5A, V _{GS} = 0V ③ |
| t _{rr} | Reverse Recovery Time | — | 45 | 68 | ns | T _J = 25°C, I _F = 7.5A, V _{DD} = 100V |
| Q _{rr} | Reverse Recovery Charge | — | 459 | 689 | nC | di/dt = 500A/μs ③ |
| t _{on} | Forward Turn-On Time | Time is dominated by parasitic Inductance | | | | |

Thermal Resistance

| | Parameter | Typ. | Max. | Units |
|---------------------------|-----------------------|------|------|-------|
| R _{θJC} (Bottom) | Junction-to-Case | 0.5 | 0.8 | °C/W |
| R _{θJC} (Top) | Junction-to-Case ④ | — | 15 | |
| R _{θJA} | Junction-to-Ambient ⑤ | — | 35 | |
| R _{θJA} (<10s) | Junction-to-Ambient ⑤ | — | 21 | |

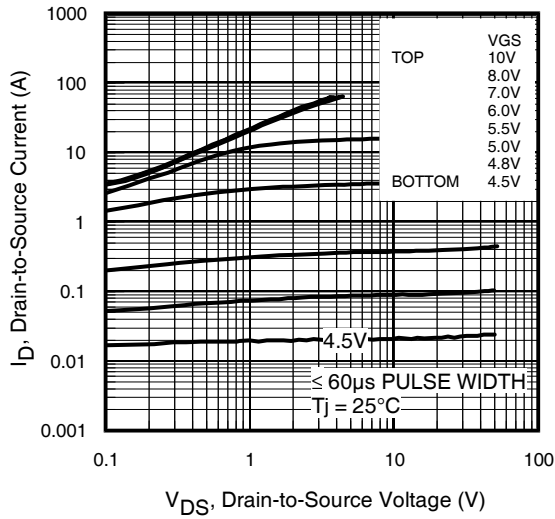
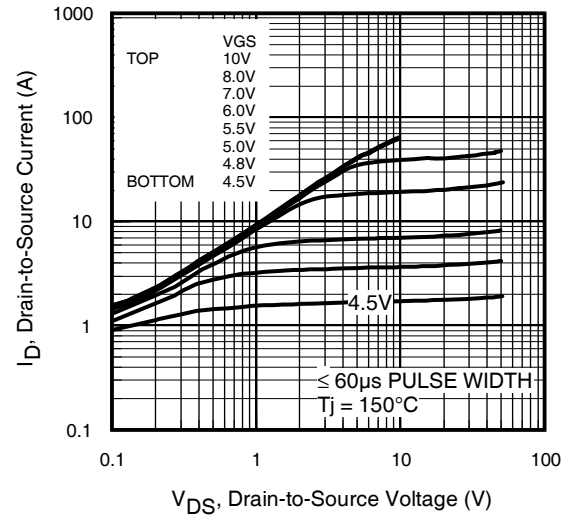
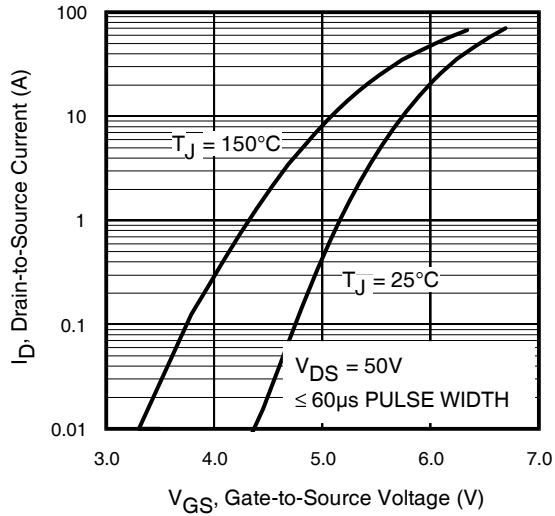
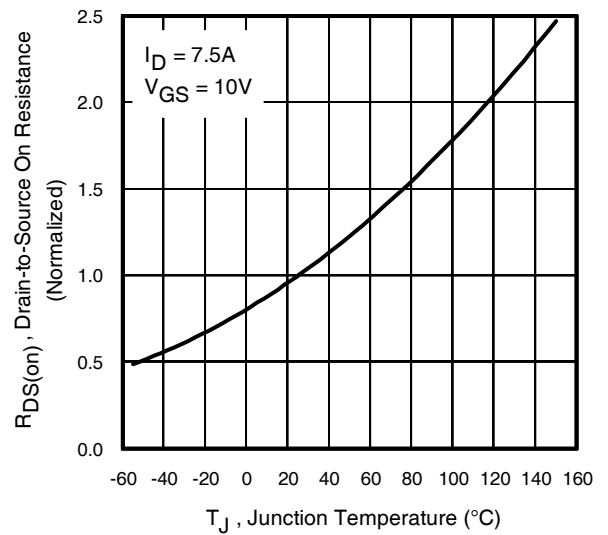
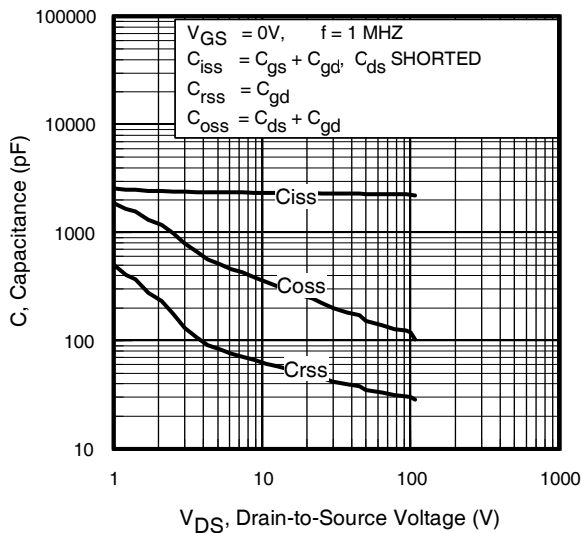
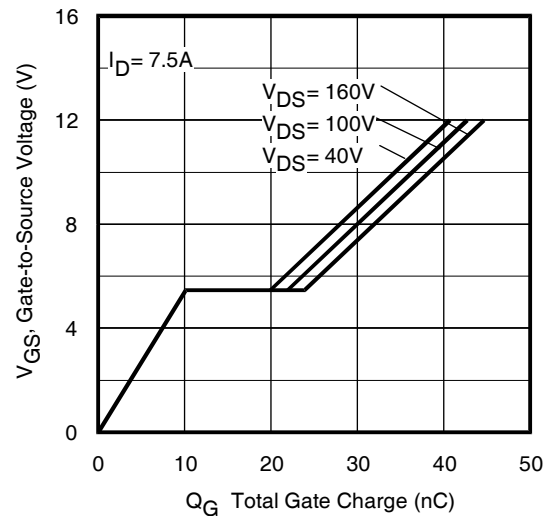
Fig 1. Typical Output Characteristics

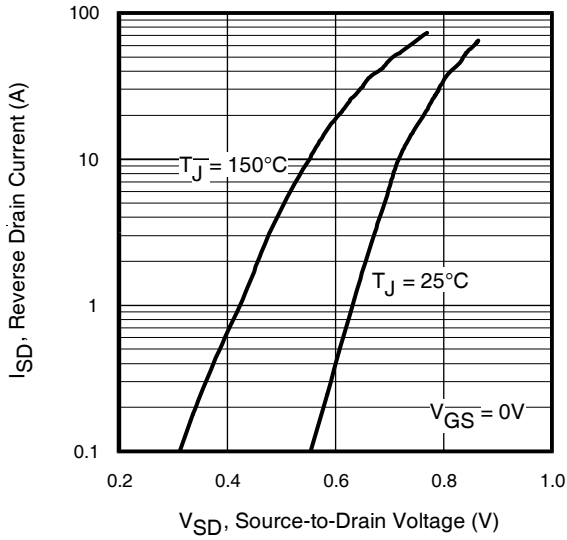
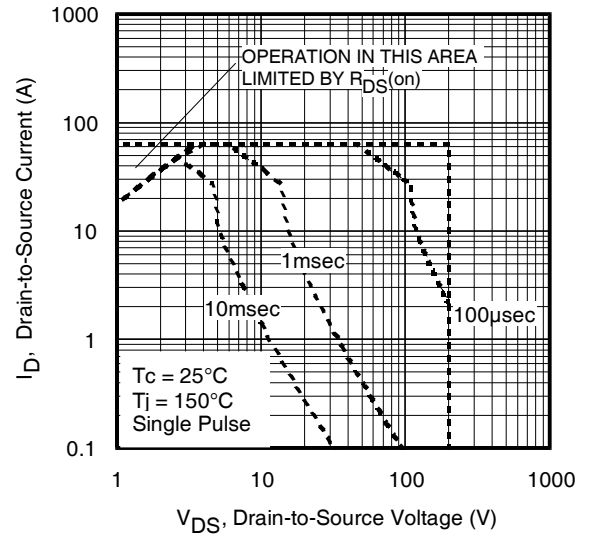
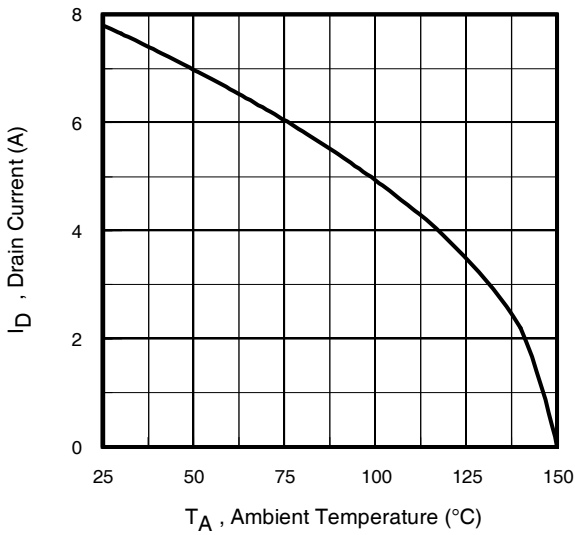
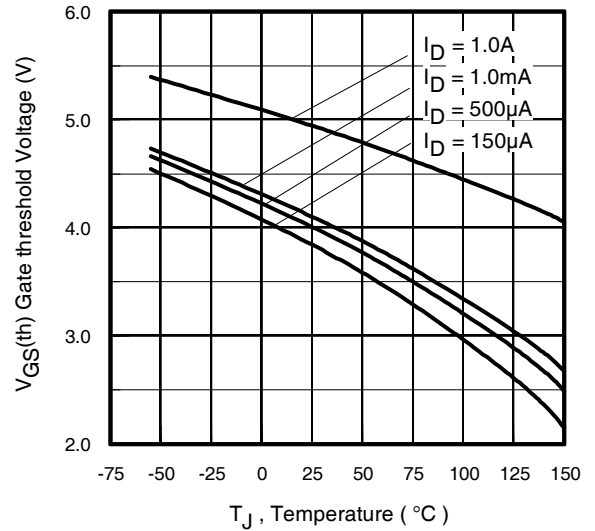
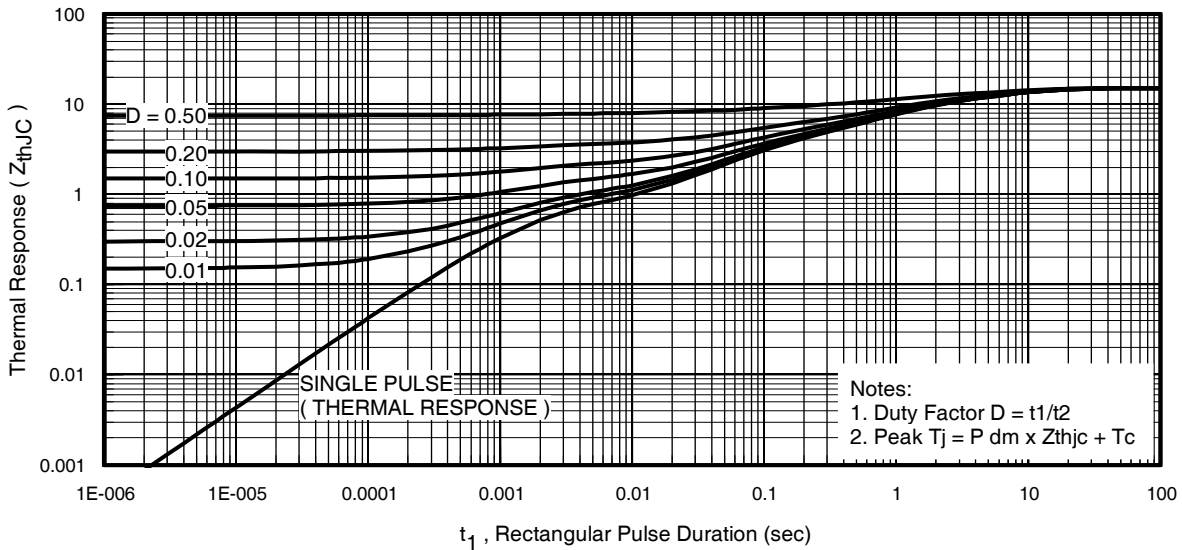
Fig 2. Typical Output Characteristics

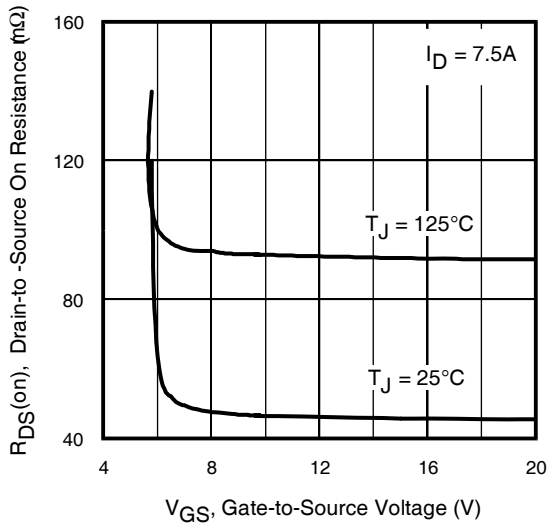
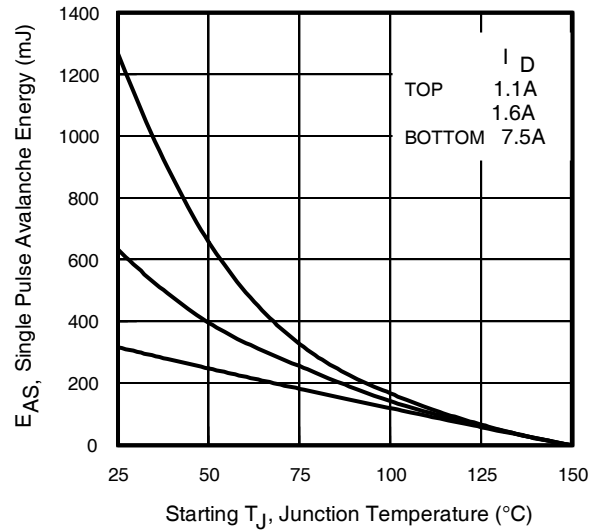
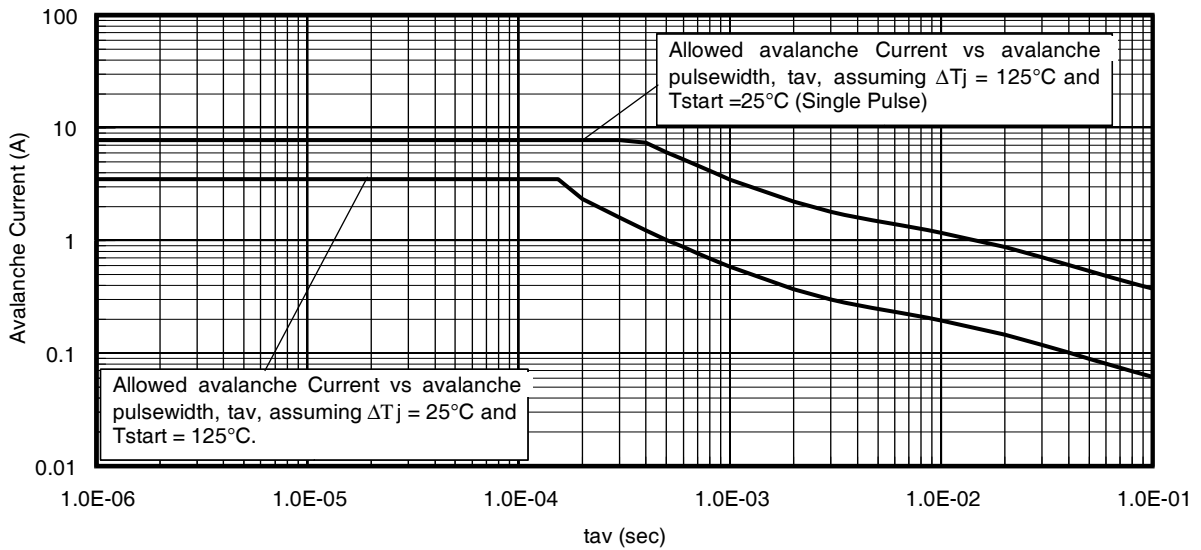
Fig 3. Typical Transfer Characteristics

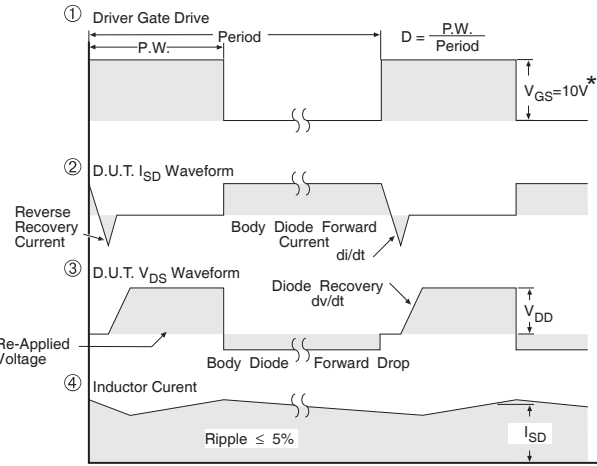
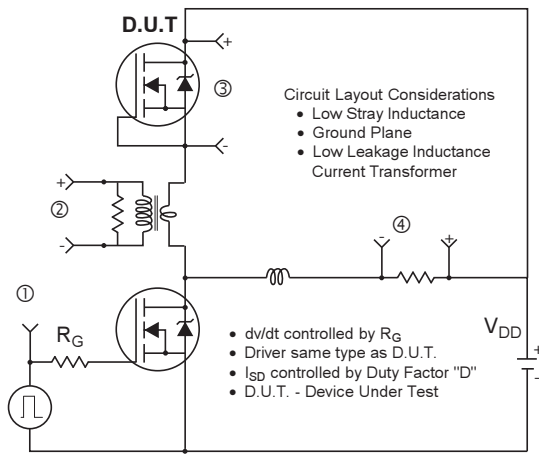
Fig 4. Normalized On-Resistance Vs. Temperature

Fig 5. Typical Capacitance Vs. Drain-to-Source Voltage

Fig 6. Typical Gate Charge Vs. Gate-to-Source Voltage

Fig 7. Typical Source-Drain Diode Forward Voltage

Fig 8. Maximum Safe Operating Area

Fig 9. Maximum Drain Current Vs. Case (Top) Temperature

Fig 10. Threshold Voltage Vs. Temperature

Fig 11. Maximum Effective Transient Thermal Impedance, Junction-to-Case (Top)

Fig 12. On-Resistance vs. Gate Voltage

Fig 13. Maximum Avalanche Energy vs. Drain Current

Fig 14. Typical Avalanche Current vs. Pulsewidth



* $V_{GS} = 5V$ for Logic Level Devices

Fig 15. Peak Diode Recovery dv/dt Test Circuit for N-Channel HEXFET[®] Power MOSFETs

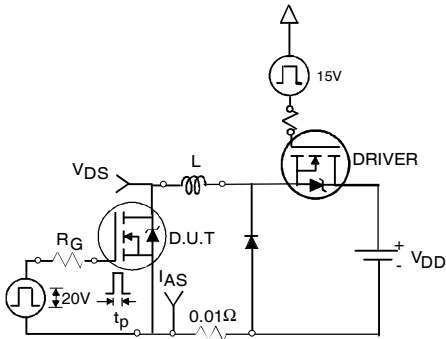

Fig 16a. Unclamped Inductive Test Circuit

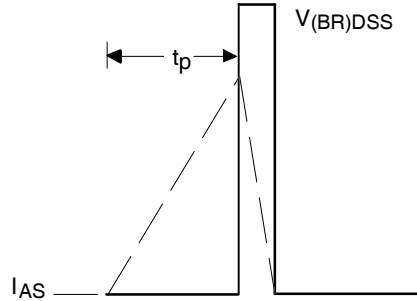

Fig 16b. Unclamped Inductive Waveforms

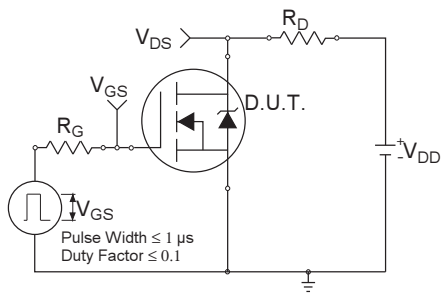

Fig 17a. Switching Time Test Circuit

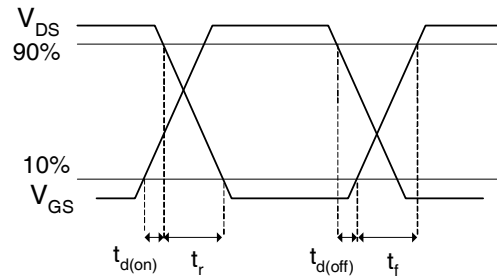

Fig 17b. Switching Time Waveforms

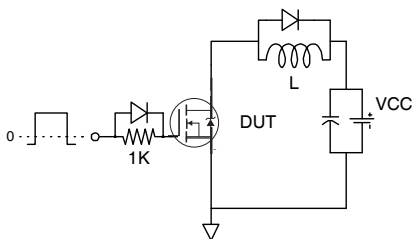

Fig 18a. Gate Charge Test Circuit

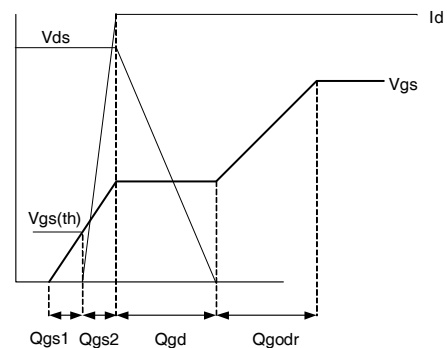
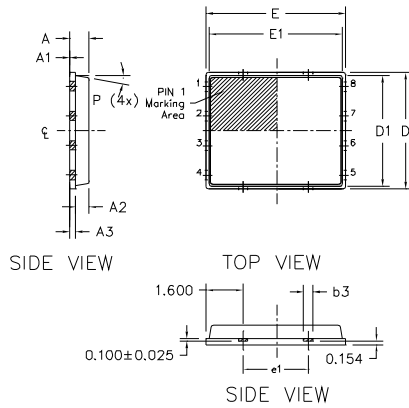

Fig 18b. Gate Charge Waveform

PQFN 5x6 Outline "B" Package Details



| DIM SYMBOL | MILLIMETERS | | INCH | |
|---------------|-------------|-------|------------|--------|
| | MIN | MAX | MIN | MAX |
| A | 0.800 | 0.900 | 0.0315 | 0.0543 |
| A1 | 0.000 | 0.050 | 0.0000 | 0.0020 |
| A3 | 0.200 REF | | 0.0079 REF | |
| b | 0.350 | 0.470 | 0.0138 | 0.0185 |
| b1 | 0.025 | 0.125 | 0.0010 | 0.0049 |
| b2 | 0.210 | 0.410 | 0.0083 | 0.0161 |
| b3 | 0.150 | 0.450 | 0.0059 | 0.0177 |
| D | 5.000 BSC | | 0.1969 BSC | |
| D1 | 4.750 BSC | | 0.1870 BSC | |
| D2 | 4.100 | 4.300 | 0.1614 | 0.1693 |
| E | 6.000 BSC | | 0.2362 BSC | |
| E1 | 5.750 BSC | | 0.2264 BSC | |
| E2 | 3.380 | 3.780 | 0.1331 | 0.1488 |
| e | 1.270 REF | | 0.0500 REF | |
| e1 | 2.800 REF | | 0.1102 REF | |
| K | 1.200 | 1.420 | 0.0472 | 0.0559 |
| L | 0.710 | 0.900 | 0.0280 | 0.0354 |
| P | 0° | 12° | 0° | 12° |
| R | 0.200 REF | | 0.0079 REF | |
| R2 | 0.150 | 0.200 | 0.0059 | 0.0079 |

- Note:**
1. Dimensions and tolerancing confirm to ASME Y14.5M-1994
 2. Dimension L represents terminal full back from package edge up to 0.1mm is acceptable
 3. Coplanarity applies to the expose Heat Slug as well as the terminal
 4. Radius on terminal is Optional

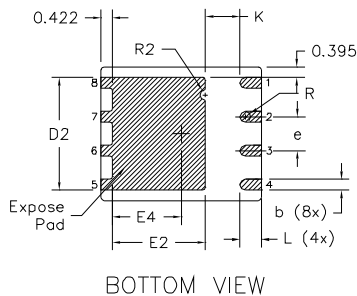

PQFN 5x6 Outline "G" Package Details

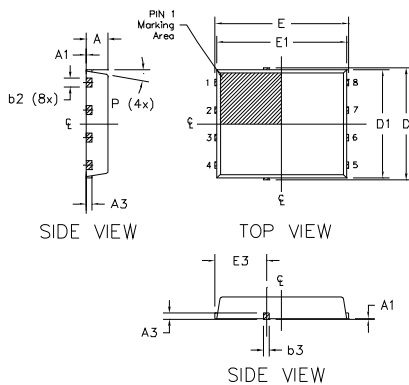

| DIM SYMBOL | MILLIMETERS | | INCH | |
|---------------|-------------|--------|------------|--------|
| | MIN. | MAX. | MIN. | MAX. |
| A | 0.950 | 1.050 | 0.0374 | 0.0413 |
| A1 | 0.000 | 0.050 | 0.0000 | 0.0020 |
| A3 | 0.254 REF | | 0.0100 REF | |
| b | 0.310 | 0.510 | 0.0122 | 0.0201 |
| b1 | 0.025 | 0.125 | 0.0010 | 0.0049 |
| b2 | 0.210 | 0.410 | 0.0083 | 0.0161 |
| b3 | 0.180 | 0.450 | 0.0071 | 0.0177 |
| D | 5.150 BSC | | 0.2028 BSC | |
| D1 | 5.000 BSC | | 0.1969 BSC | |
| D2 | 3.700 | 3.900 | 0.1457 | 0.1535 |
| E | 6.150 BSC | | 0.2421 BSC | |
| E1 | 6.000 BSC | | 0.2362 BSC | |
| E2 | 3.560 | 3.760 | 0.1402 | 0.1488 |
| E3 | 2.270 | 2.470 | 0.0894 | 0.0972 |
| e | 1.27 REF | | 0.050 REF | |
| K | 0.830 | 1.400 | 0.0327 | 0.0551 |
| L | 0.510 | 0.710 | 0.0201 | 0.0280 |
| L1 | 0.510 | 0.710 | 0.0201 | 0.0280 |
| P | 10 deg | 12 deg | 0 deg | 12 deg |

- Note:**
1. Dimensions and tolerancing confirm to ASME Y14.5M-1994
 2. Dimension L represents terminal full back from package edge up to 0.1mm is acceptable
 3. Coplanarity applies to the expose Heat Slug as well as the terminal
 4. Radius on terminal is Optional

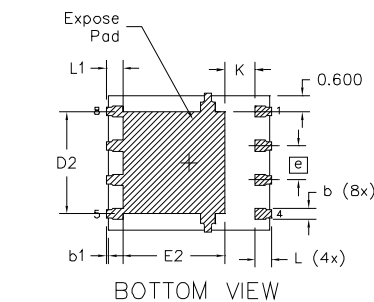

For more information on board mounting, including footprint and stencil recommendation, please refer to application note AN-1136:

<http://www.irf.com/technical-info/appnotes/an-1136.pdf>

For more information on package inspection techniques, please refer to application note AN-1154:

<http://www.irf.com/technical-info/appnotes/an-1154.pdf>

Note: For the most current drawing please refer to IR website at: <http://www.irf.com/package/>

PQFN 5x6 Part Marking

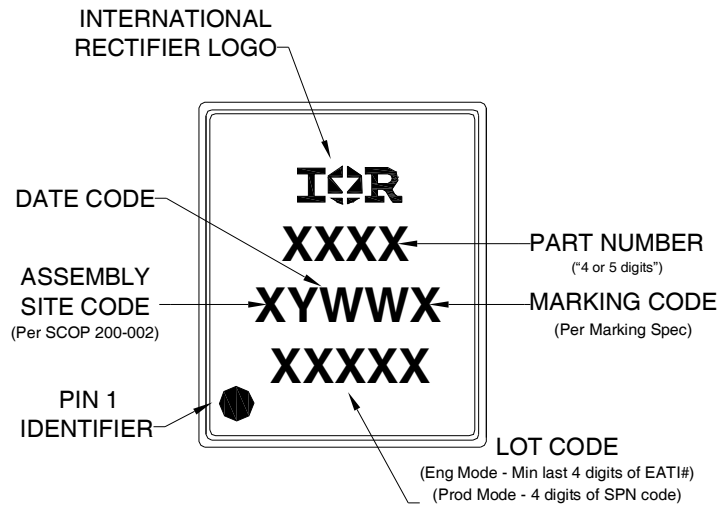

PQFN 5x6 Tape and Reel

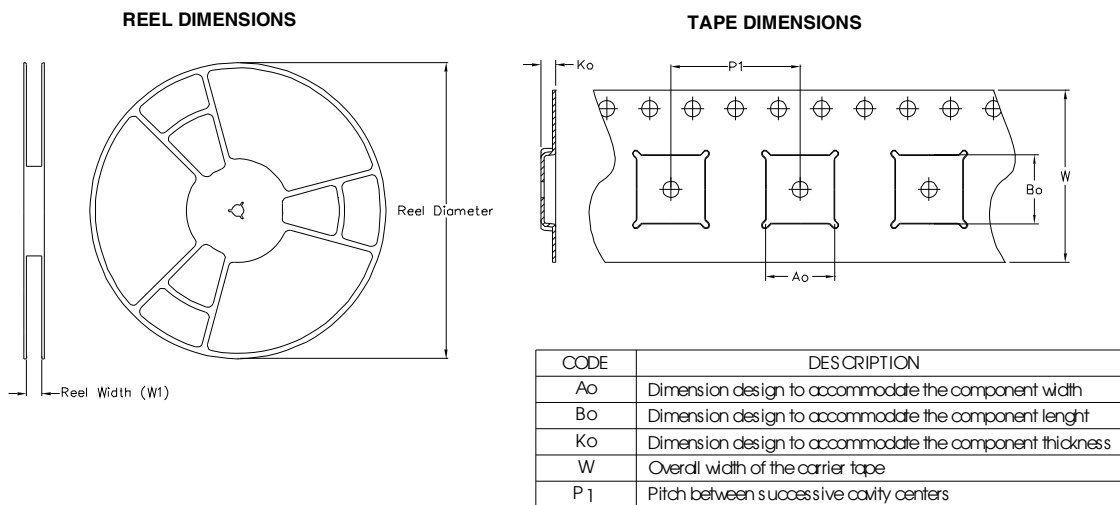

QUADRANT ASSIGNMENTS FOR PIN 1 ORIENTATION IN TAPE

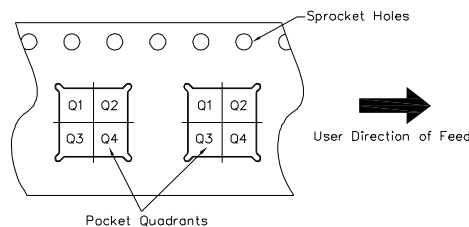

Note: All dimension are nominal

| Package Type | Reel Diameter (Inch) | QTY | Reel Width W1 (mm) | Ao (mm) | Bo (mm) | Ko (mm) | P1 (mm) | W (mm) | Pin 1 Quadrant |
|--------------|----------------------|------|--------------------|---------|---------|---------|---------|--------|----------------|
| 5 X 6 PQFN | 13 | 4000 | 12.4 | 6.300 | 5.300 | 1.20 | 8.00 | 12 | Q1 |

Note: For the most current drawing please refer to IR website at: <http://www.irf.com/package/>

Qualification information[†]

| | | |
|----------------------------|---|--|
| Qualification level | Industrial ^{††} (per JEDEC JESD47F ^{†††} guidelines) | |
| Moisture Sensitivity Level | PQFN 5mm x 6mm | MSL1 (per JEDEC J-STD-020D ^{†††}) |
| RoHS compliant | Yes | |

† Qualification standards can be found at International Rectifier's web site
<http://www.irf.com/product-info/reliability>

†† Higher qualification ratings may be available should the user have such requirements.
 Please contact your International Rectifier sales representative for further information:
<http://www.irf.com/whoto-call/salesrep/>

††† Applicable version of JEDEC standard at the time of product release.

Notes:

- ① Repetitive rating; pulse width limited by max. junction temperature.
- ② Starting $T_J = 25^\circ\text{C}$, $L = 11.3\text{mH}$, $R_G = 25\Omega$, $I_{AS} = 7.5\text{A}$.
- ③ Pulse width $\leq 400\mu\text{s}$; duty cycle $\leq 2\%$.
- ④ R_θ is measured at T_J of approximately 90°C .
- ⑤ When mounted on 1 inch square 2 oz copper pad on 1.5x1.5 in. board of FR-4 material.

Revision History

| Date | Comment |
|-----------|---|
| 4/14/2014 | <ul style="list-style-type: none"> • Updated ordering information to reflect the End-Of-Life (EOL) of the mini-reel option (EOL notice #259) on page 1 • Corrected typo on Breakdown Voltage Temp. Coefficient from "0.02V/C" to "0.22V/C" on page 2. • Updated Package outline on page 7. • Updated data sheet with the new IR corporate template. |
| 5/5/2014 | <ul style="list-style-type: none"> • Updated T_{rr} Typ/Max from "46/69ns" to "45/68ns" on page 2. • Updated Q_{rr} Typ/Max from "97/150nC" to "459/689nC" on page 2. |
| 4/28/2015 | <ul style="list-style-type: none"> • Updated package outline for "option B" and added package outline for "option G" on page 7 • Updated tape and reel on page 8. |
| 5/19/2015 | <ul style="list-style-type: none"> • Updated package outline for "option G" on page 7. • Updated "IFX logo" on page 1 and page 9. |

Данный компонент на территории Российской Федерации

Вы можете приобрести в компании MosChip.

Для оперативного оформления запроса Вам необходимо перейти по данной ссылке:

<http://moschip.ru/get-element>

Вы можете разместить у нас заказ для любого Вашего проекта, будь то серийное производство или разработка единичного прибора.

В нашем ассортименте представлены ведущие мировые производители активных и пассивных электронных компонентов.

Нашей специализацией является поставка электронной компонентной базы двойного назначения, продукции таких производителей как XILINX, Intel (ex.ALTERA), Vicor, Microchip, Texas Instruments, Analog Devices, Mini-Circuits, Amphenol, Glenair.

Сотрудничество с глобальными дистрибьюторами электронных компонентов, предоставляет возможность заказывать и получать с международных складов практически любой перечень компонентов в оптимальные для Вас сроки.

На всех этапах разработки и производства наши партнеры могут получить квалифицированную поддержку опытных инженеров.

Система менеджмента качества компании отвечает требованиям в соответствии с ГОСТ Р ИСО 9001, ГОСТ РВ 0015-002 и ЭС РД 009

Офис по работе с юридическими лицами:

105318, г.Москва, ул.Щербаковская д.3, офис 1107, 1118, ДЦ «Щербаковский»

Телефон: +7 495 668-12-70 (многоканальный)

Факс: +7 495 668-12-70 (доб.304)

E-mail: info@moschip.ru

Skype отдела продаж:

moschip.ru

moschip.ru_4

moschip.ru_6

moschip.ru_9