

Spezifikation für Freigabe / specification for release

Kunde / customer :

Artikelnummer / part number : **7448225007**

Bezeichnung : **STROMKOMP. DROSSEL WE-CMB HC**

description : **COMMON MODE CHOKE WE-CMB HC**



DATUM / DATE : 2009-01-20

A Mechanische Abmessungen / dimensions:

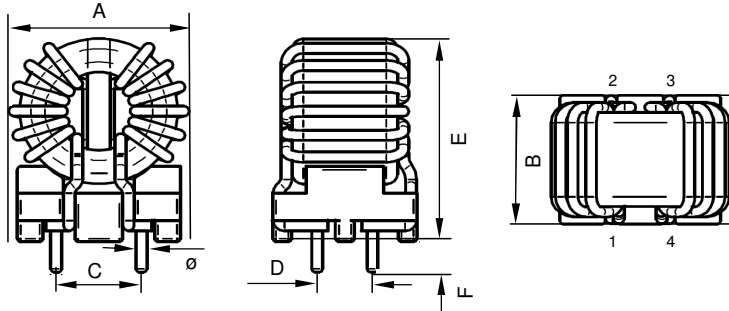

	S	
A	18,5 max	mm
B	14,5 max	mm
C	7,7 ± 0,5	mm
D	5,0 ± 0,5	mm
E	22,0 max.	mm
F	3,5 ± 0,5	mm
ø	1,0 typ.	mm

B Elektrische Eigenschaften / electrical properties:

Eigenschaften / properties	Testbedingungen / test conditions		Wert / value	Einheit / unit	tol.
Leerlauf-Induktivität / inductance	100 kHz / 0,1 mA / 20 °C	L _O	700	μH	±30%
DC-Widerstand / DC-resistance	@ 20 °C	R _{DC}	13,0	mΩ	±10%
Nennstrom / rated current	@ 70 °C	I _N	5,00	A	max.
Nennspannung / rated voltage	50 Hz	U _N	250	V	max.

C Schaltbild / schematic:

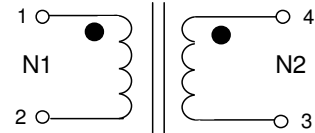

D Prüfgeräte / test equipment:

WAYNE KERR WK3260B/WK3265 für/for L₀ und/and R_{DC}

HP 34401 A für/for IN

E Testbedingungen / test conditions:

Luftfeuchtigkeit / humidity:	33%
Umgebungstemperatur / temperature:	+20 °C
Prüfspannung / testing voltage	1500 V, 50 Hz
	5mA, 2 sec.

F Werkstoffe & Zulassungen / material & approvals:

Sockel / base:	UL94V-0
Draht / wire:	Class F
Kleber / glue:	UL94V-2
Abstandhalter / spacer:	UL94V-0

G Eigenschaften / general specifications:

Klimabeständigkeit/ climatic class:	40/125/21
Betriebstemp. / operating temperature:	-40 °C - + 125 °C
Übertemperatur / temperature rise:	< 55 K
It is recommended that the temperature of the part does not exceed 125 °C under worst case operating conditions.	

Freigabe erteilt / general release:

Kunde / customer

Datum / date

Unterschrift / signature

Würth Elektronik

Geprüft / checked

Kontrolliert / approved

BKo	Version 1	09-01-30
Name	Änderung / modification	Datum / date

This electronic component has been designed and developed for usage in general electronic equipment. Before incorporating this component into any equipment where higher safety and reliability is especially required or if there is the possibility of direct damage or injury to human body, for example in the range of aerospace, aviation, nuclear control, submarine, transportation, (automotive control, train control, ship control), transportation signal, disaster prevention, medical, public information network etc, Würth Elektronik eiSos GmbH must be informed before the design-in stage. In addition, sufficient reliability evaluation checks for safety must be performed on every electronic component which is used in electrical circuits that require high safety and reliability functions or performance.

Würth Elektronik eiSos GmbH & Co. KG

D-74638 Waldenburg · Max-Eyth-Strasse 1 - 3 · Germany · Telefon (+49) (0) 7942 - 945 - 0 · Telefax (+49) (0) 7942 - 945 - 400
http://www.we-online.com

Spezifikation für Freigabe / specification for release

Kunde / customer :
 Artikelnummer / part number : **7448225007**
 Bezeichnung : **STROMKOMP. DROSSEL WE-CMB HC**
 description : **COMMON MODE CHOKE WE-CMB HC**



DATUM / DATE : 2009-01-20

H Einfügdämpfung / insertion loss:

typischer Dämpfungsverlauf / typical attenuation curve

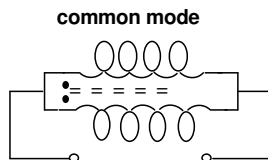
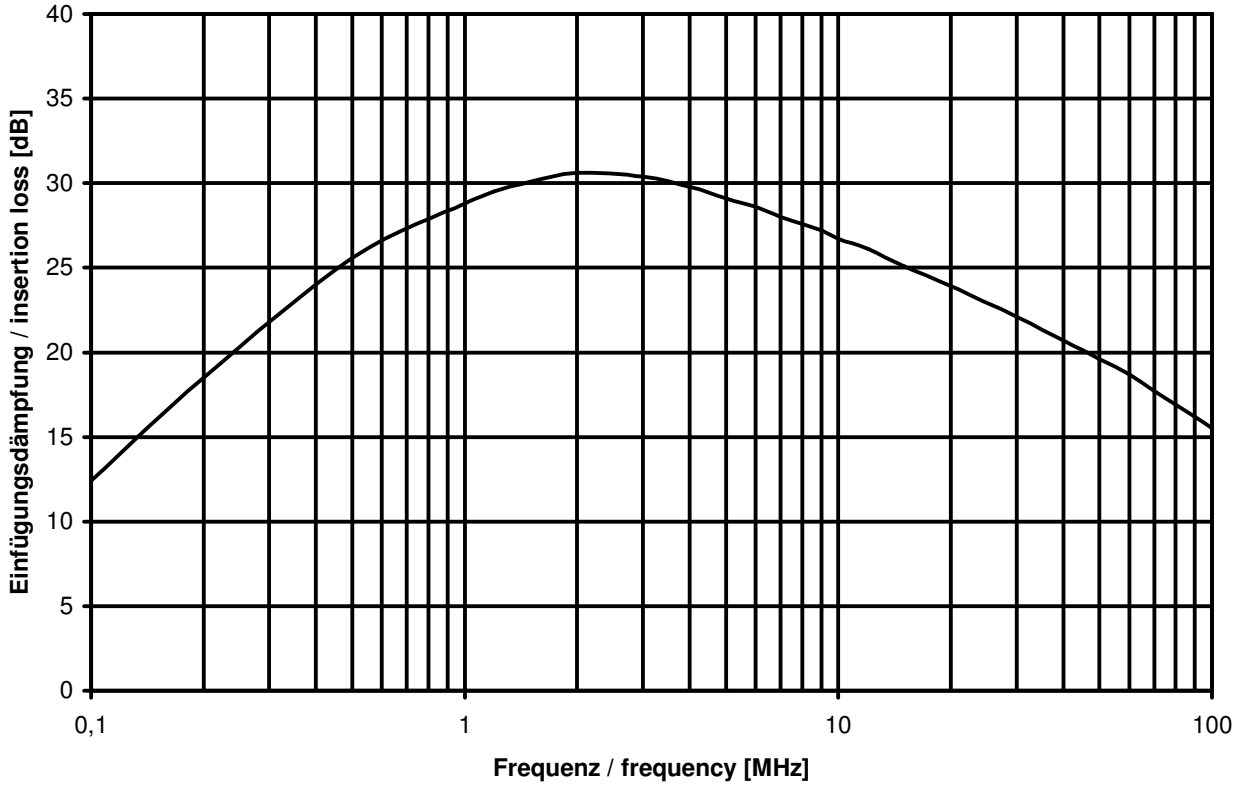

Datum / date							
Geprüft / checked							
Kontrolliert / approved							
	<table border="1" style="width: 100%; border-collapse: collapse;"> <tr> <td style="width: 33%;">BKo</td> <td style="width: 33%;">Version 1</td> <td style="width: 33%;">09-01-30</td> </tr> <tr> <td style="width: 33%;">Name</td> <td style="width: 33%;">Änderung / modification</td> <td style="width: 33%;">Datum / date</td> </tr> </table>	BKo	Version 1	09-01-30	Name	Änderung / modification	Datum / date
BKo	Version 1	09-01-30					
Name	Änderung / modification	Datum / date					

This electronic component has been designed and developed for usage in general electronic equipment. Before incorporating this component into any equipment where higher safety and reliability is especially required or if there is the possibility of direct damage or injury to human body, for example in the range of aerospace, aviation, nuclear control, submarine, transportation, (automotive control, train control, ship control), transportation signal, disaster prevention, medical, public information network etc, Würth Elektronik eiSos GmbH must be informed before the design-in stage. In addition, sufficient reliability evaluation checks for safety must be performed on every electronic component which is used in electrical circuits that require high safety and reliability functions or performance.

Würth Elektronik eiSos GmbH & Co. KG

D-74638 Waldenburg · Max-Eyth-Strasse 1 - 3 · Germany · Telefon (+49) (0) 7942 - 945 - 0 · Telefax (+49) (0) 7942 - 945 - 400
<http://www.we-online.com>

Данный компонент на территории Российской Федерации

Вы можете приобрести в компании MosChip.

Для оперативного оформления запроса Вам необходимо перейти по данной ссылке:

<http://moschip.ru/get-element>

Вы можете разместить у нас заказ для любого Вашего проекта, будь то серийное производство или разработка единичного прибора.

В нашем ассортименте представлены ведущие мировые производители активных и пассивных электронных компонентов.

Нашей специализацией является поставка электронной компонентной базы двойного назначения, продукции таких производителей как XILINX, Intel (ex.ALTERA), Vicor, Microchip, Texas Instruments, Analog Devices, Mini-Circuits, Amphenol, Glenair.

Сотрудничество с глобальными дистрибьюторами электронных компонентов, предоставляет возможность заказывать и получать с международных складов практически любой перечень компонентов в оптимальные для Вас сроки.

На всех этапах разработки и производства наши партнеры могут получить квалифицированную поддержку опытных инженеров.

Система менеджмента качества компании отвечает требованиям в соответствии с ГОСТ Р ИСО 9001, ГОСТ РВ 0015-002 и ЭС РД 009

Офис по работе с юридическими лицами:

105318, г.Москва, ул.Щербаковская д.3, офис 1107, 1118, ДЦ «Щербаковский»

Телефон: +7 495 668-12-70 (многоканальный)

Факс: +7 495 668-12-70 (доб.304)

E-mail: info@moschip.ru

Skype отдела продаж:

moschip.ru

moschip.ru_4

moschip.ru_6

moschip.ru_9