

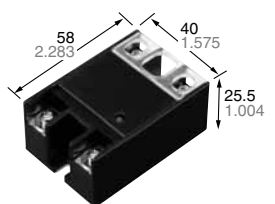

**Small Screw Terminal SSR  
Ideal for DC Control**

**AQ-A (DC output type)  
Solid State Relays**



mm inch

**RoHS compliant**

### FEATURES

- 1. Compact Size**  
W 40 × L 58 × H 25.5 mm  
W 1.575 × L 2.283 × H 1.004 inch
- 2. With terminal cover for safety (output side only).**  
\* Cover on input side available as option.
- 3. Mounting pitch 47.5 mm 1.870 inch**
- 4. Internal diode protects element on output side**
- 5. With LED indication for operation status verification**

### TYPICAL APPLICATIONS

- Photovoltaic power generation system
- Storage battery system
- For control of all types of business equipment and industrial use DC heaters/motors, etc.

## ORDERING INFORMATION

**AQAD**

Output current

1: 10 A

5: 30 A

Load voltage, Type

5: 100 V DC, Screw terminal

7: 600 V DC, Screw terminal

Control voltage

1: 4 to 32 V DC

Functions

DL: Internal diode and LED indication

\* When the load voltage is AC type, please refer to "AQ-A RELAYS (AC only)".

## TYPES

### 1. AQ-A Solid State Relays (DC only)

Type	Load current	Load voltage	Control voltage	Part No.
DC output	30 A	100 V DC	4 to 32 V DC	AQAD551DL
	10 A	600 V DC		AQAD171DL

Standard Packing; carton: 2 pcs., case: 60 pcs.

### 2. Accessories

Type	Part No.
Standard heat sink	AQP-HS-J25A
Slim heat sink (45 mm 1.772inch wide) (Mountable on a DIN rail)	AQP-HS-SJ20A
DIN rail mounting plate	AQP-DPJ
Terminal cover	AQA801
Mounting rail	AT8-DLA1
Fastening plate	AT8-DLE

# AQ-A (DC only) Solid State Relays

## RATING

### 1. Ratings (Measurement condition: at 20°C 68°F, Input ripple: 1% or less)

Item		Part No.	AQAD551DL	AQAD171DL	Remarks
Input side	Control voltage		4 to 32 V DC		
	Input current		Max. 20 mA		
	Drop-out voltage		Min. 1 V		
Output side	Max. load current (DC)		30 A	10 A	
	Peak load current		90 A (V <sub>L</sub> = 60 V DC)	20 A (V <sub>L</sub> = 600 V DC)	100 ms (1 shot)
	Max. load voltage (DC)		100 V	600 V	
	"OFF-state" leakage current		Max. 100 μA		V <sub>L</sub> = Max.
	"ON" resistance		Max. 20 mΩ	Max. 200 mΩ	at Max. carrying current
	Max. power dissipation		20 W		

### 2. Characteristics (Measurement condition: at 20°C 68°F, Input ripple: 1% or less)

Item		Part No.	AQAD551DL	AQAD171DL	Condition
Operate time			Max. 10 ms	Max. 5 ms	V <sub>IN</sub> = 4 V, I <sub>L</sub> = 1 A, V <sub>L</sub> = 10 V Resistance load
Release time			Max. 3 ms	Max. 1 ms	V <sub>IN</sub> = 4 V, I <sub>L</sub> = 1 A, V <sub>L</sub> = 10 V Resistance load
Insulation resistance			100 MΩ between input and output		at 500 V DC
Breakdown voltage			4,000 Vrms between input and output 2,500 Vrms between input, output and case		for 1 minute
Vibration resistance			10 to 55 Hz double amplitude of 1.5 mm .059 inch		X, Y, Z axes
Shock resistance			Min. 980 m/s <sup>2</sup>		X, Y, Z axes
Ambient temperature	Operating		-20 to +80°C -4 to +176°F		(Non-icing at low temperatures)
	Storage		-20 to +85°C -4 to +185°F		(Non-icing at low temperatures)
Max. operating frequency			0.5 cps		V <sub>IN</sub> = 4 V, duty = 50%, I <sub>L</sub> = Max., V <sub>L</sub> = Max.

Note: V<sub>IN</sub> is input voltage, I<sub>L</sub> is load current, and V<sub>L</sub> is load voltage.

## REFERENCE DATA

1. Load current vs. ambient temperature characteristics  
Use load current within range specified in the figure below.

Tested condition

### With external heat sink

When using heat sink (AQP-HS-J25A) or (AQP-HS-SJ20A)

1) If attached to a heat sink, use a heat conductive compound (Ex. Momentive Performance Materials Inc. YG6111 or TSK5303) of similar coating to improve cooling.

### Without external heat sink

If the mounting surface is not metallic and a heat sink is not used, expose the bottom surface and plate surface to improve heat dissipation.

(1) 30 A type (AQAD551DL)

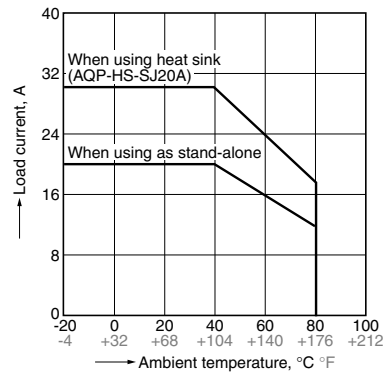

(2) 10 A type (AQAD171DL)

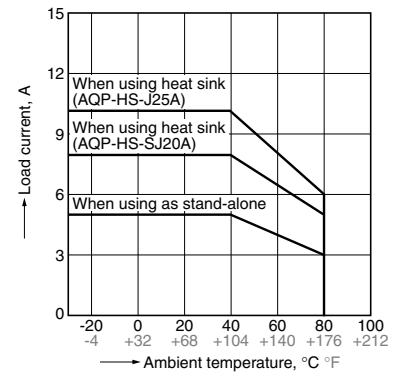

2. Max. operating frequency vs. load voltage × load current characteristics

(1) 30 A type (AQAD551DL)

Ambient temperature: 20°C 68°F

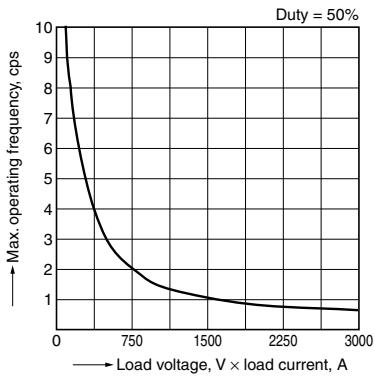

(2) 10 A type (AQAD171DL)

Ambient temperature: 20°C 68°F

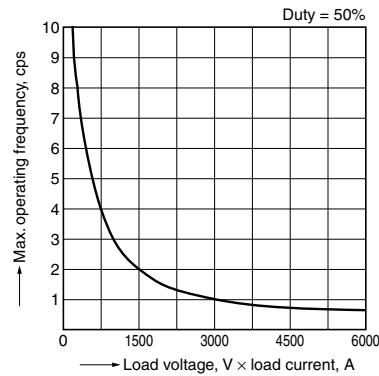

3. Input current vs. input voltage characteristics

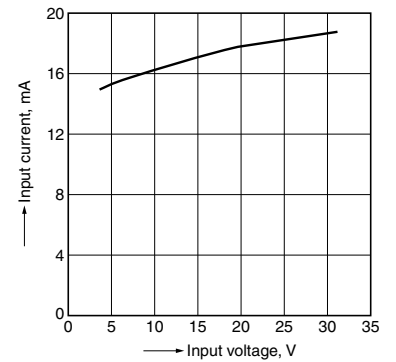

## DIMENSIONS (mm inch)

CAD



The CAD data of the products with a **CAD** mark can be downloaded from: <https://industrial.panasonic.com/ac/e/>

### External dimensions

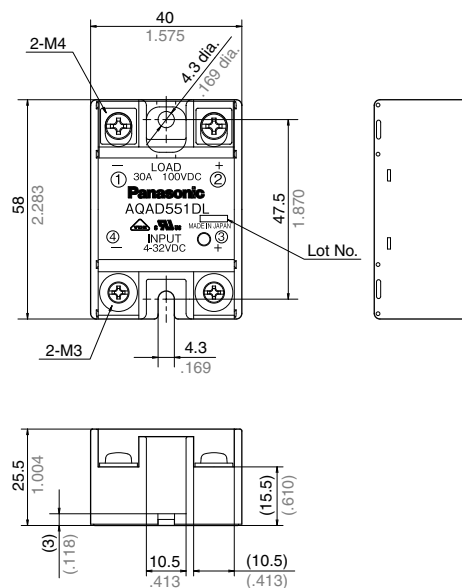

### Mounting dimensions

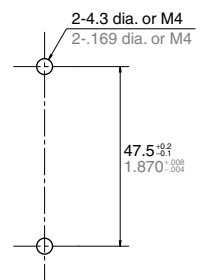

General tolerance:  $\pm 1.0 \pm .039$

# AQ-A (DC only) Solid State Relays

## ACCESSORIES (mm inch)

The CAD data of the products with a **CAD** mark can be downloaded from: <https://industrial.panasonic.com/ac/e/>

### AQP-HS-SJ20A Slim Heat Sink

**CAD**



#### External dimensions

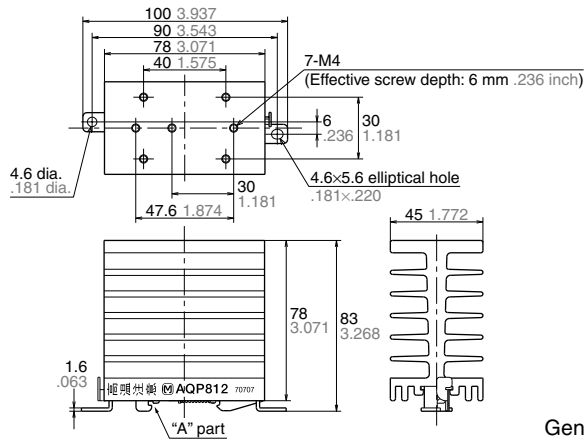

#### Mounting dimensions

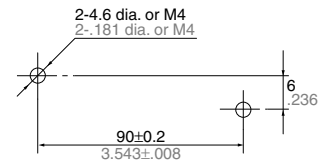

General tolerance:  $\pm 1.0 \pm .039$

Note: When using on a DIN rail, please install so that the "A" part is on top.

### AQP-HS-J25A Standard Heat Sink

**CAD**



#### External dimensions

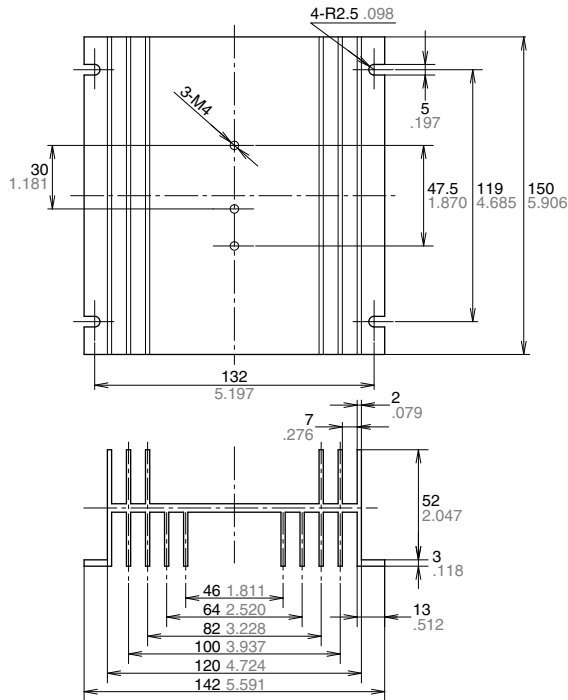

#### Mounting dimensions

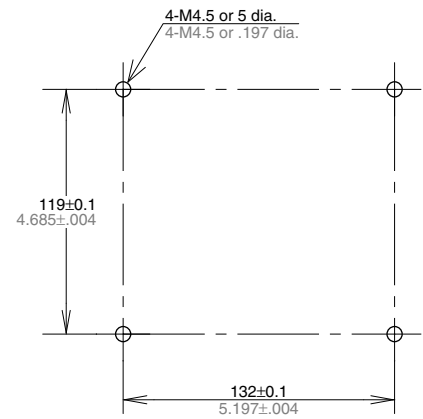

General tolerance:  $\pm 1.0 \pm .039$

**AQP-DPJ DIN Rail Mounting Plate**

**CAD**

External dimensions

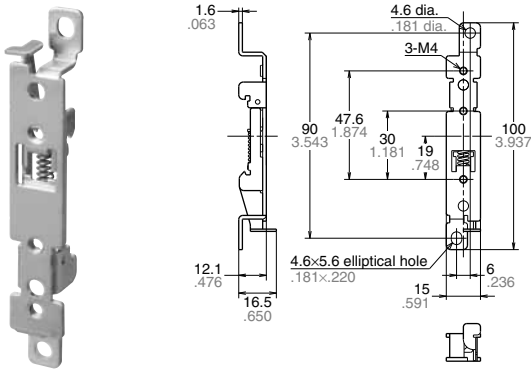

General tolerance:  $\pm 1.0 \pm .039$

**AT8-DLA1 Mounting Rail**

**CAD**

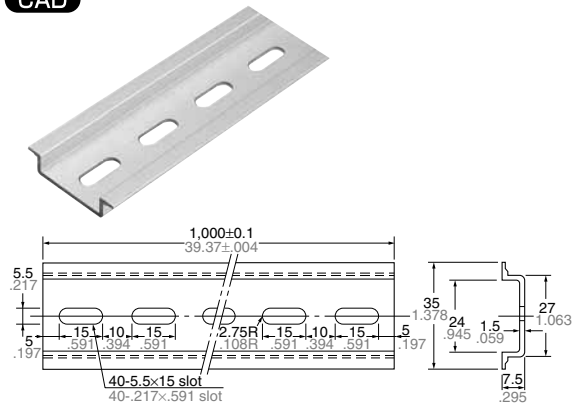

**AT8-DLE Fastening plate**

**CAD**

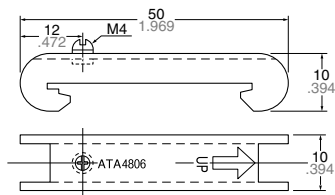

**AQA801 Terminal cover**

**CAD**

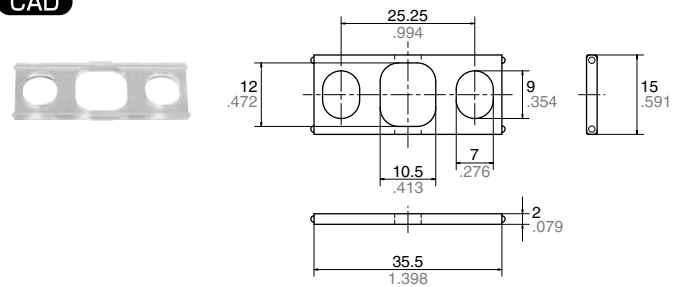

Use this product as a protective terminal cover for AQ-A/SSR. It can be used for either the input or output side.

General tolerance:  $\pm 1.0 \pm .039$

**SCHEMATIC AND WIRING DIAGRAMS**

Schematic	Output configuration	Load	Wiring diagram
	1 Form A	DC	

---

Please contact .....

**Panasonic Corporation**

Electromechanical Control Business Division

■ 1006, Oaza Kadoma, Kadoma-shi, Osaka 571-8506, Japan  
[industrial.panasonic.com/ac/e/](http://industrial.panasonic.com/ac/e/)

**Panasonic**<sup>®</sup>

©Panasonic Corporation 2018

# Mouser Electronics

Authorized Distributor

Click to View Pricing, Inventory, Delivery & Lifecycle Information:

Panasonic:

[AQAD551DL](#) [AQAD171DL](#)

## Данный компонент на территории Российской Федерации

### Вы можете приобрести в компании MosChip.

Для оперативного оформления запроса Вам необходимо перейти по данной ссылке:

<http://moschip.ru/get-element>

Вы можете разместить у нас заказ для любого Вашего проекта, будь то серийное производство или разработка единичного прибора.

В нашем ассортименте представлены ведущие мировые производители активных и пассивных электронных компонентов.

Нашей специализацией является поставка электронной компонентной базы двойного назначения, продукции таких производителей как XILINX, Intel (ex.ALTERA), Vicor, Microchip, Texas Instruments, Analog Devices, Mini-Circuits, Amphenol, Glenair.

Сотрудничество с глобальными дистрибьюторами электронных компонентов, предоставляет возможность заказывать и получать с международных складов практически любой перечень компонентов в оптимальные для Вас сроки.

На всех этапах разработки и производства наши партнеры могут получить квалифицированную поддержку опытных инженеров.

Система менеджмента качества компании отвечает требованиям в соответствии с ГОСТ Р ИСО 9001, ГОСТ РВ 0015-002 и ЭС РД 009

### Офис по работе с юридическими лицами:

105318, г.Москва, ул.Щербаковская д.3, офис 1107, 1118, ДЦ «Щербаковский»

Телефон: +7 495 668-12-70 (многоканальный)

Факс: +7 495 668-12-70 (доб.304)

E-mail: [info@moschip.ru](mailto:info@moschip.ru)

Skype отдела продаж:

moschip.ru

moschip.ru\_4

moschip.ru\_6

moschip.ru\_9