

24-BIT SERIAL TO PARALLEL CONVERTER

■ GENERAL DESCRIPTION

The **NJU3719A** is a 24-bit serial to parallel converter especially applying to MPU output expander. It can operate from 2.4V to 5.5V.

The effective output assignment of MPU is available as the connection between **NJU3719A** and MPU using only 4 lines.

The serial data synchronizing with 5MHz or more clock can be input to the serial data input terminal and the data are output from parallel output buffer through serial in parallel out shift register and parallel data latches.

The hysteresis input circuit realizes wide noise margin and the high drive-ability output buffer (25mA) can drive LED directly.

■ PACKAGE OUTLINE



NJU3719AV

■ FEATURES

- 24-Bit Serial In Parallel Out
- Hysteresis Input 0.5V typ at 5V
- Operating Voltage 2.4 to 5.5V
- Maximum Operating Frequency 5MHz
- Output Current 25mA at 5V, 5mA at 3V
- C-MOS Technology
- Package Outline SSOP32

■ PIN CONFIGURATION

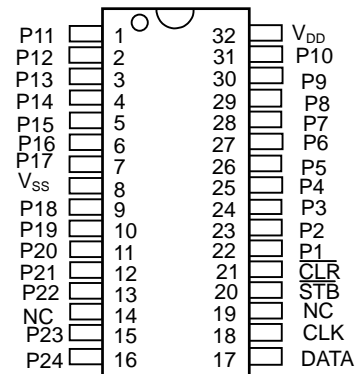

NJU3719AV

■ BLOCK DIAGRAM

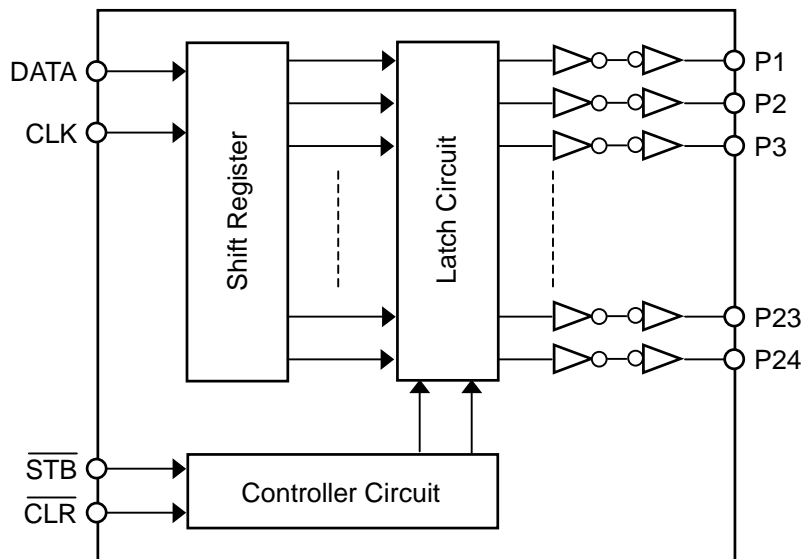

■ TERMINAL DESCRIPTION

| No. | SYMBOL | I/O | FUNCTION |
|-----|-------------------------|-----|---|
| 1 | P11 | O | Parallel Conversion Data Output Terminals |
| 2 | P12 | O | |
| 3 | P13 | O | |
| 4 | P14 | O | |
| 5 | P15 | O | |
| 6 | P16 | O | |
| 7 | P17 | O | |
| 8 | V _{SS} | - | GND |
| 9 | P18 | O | Parallel Conversion Data Output Terminals |
| 10 | P19 | O | |
| 11 | P20 | O | |
| 12 | P21 | O | |
| 13 | P22 | O | |
| 14 | NC | - | Non Connection |
| 15 | P23 | O | Parallel Conversion Data Output Terminals |
| 16 | P24 | O | |
| 17 | DATA | I | Serial Data Input Terminal |
| 18 | CLK | I | Clock Signal Input Terminal |
| 19 | NC | - | Non Connection |
| 20 | $\overline{\text{STB}}$ | I | Strobe Signal Input Terminal |
| 21 | $\overline{\text{CLR}}$ | I | Clear Signal Input Terminal |
| 22 | P1 | O | Parallel Conversion Data Output Terminals |
| 23 | P2 | | |
| 24 | P3 | | |
| 25 | P4 | | |
| 26 | P5 | | |
| 27 | P6 | O | |
| 28 | P7 | O | |
| 29 | P8 | O | |
| 30 | P9 | O | |
| 31 | P10 | O | |
| 32 | V _{DD} | - | Power Supply Terminal (2.4 to 5.5V) |

■ FUNCTIONAL DESCRIPTION

(1) Reset

When the "L" level is input to the $\overline{\text{CLR}}$ terminal, all latches are reset and all of parallel conversion output are "L" level.

Normally, the $\overline{\text{CLR}}$ terminal should be "H" level.



(2) Data Transmission

In the $\overline{\text{STB}}$ terminal is "H" level and the clock signals are inputted to the CLK terminal, the serial data into the DATA terminal are shifted in the shift register synchronizing at a rising edge of the clock signal.

When the $\overline{\text{STB}}$ terminal is changed to "L" level, the data in the shift register are transferred to the latches.

Even if the $\overline{\text{STB}}$ terminal is "L" level, the input clock signal shifts the data in the shift register, therefore, the clock signal should be controlled for data order.

Furthermore, the 4 input circuits provide a hysteresis characteristics using the schmitt trigger structure to protect the noise.

| CLK | $\overline{\text{STB}}$ | $\overline{\text{CLR}}$ | OPERATION |
|---|-------------------------|-------------------------|---|
| X | X | L | All of latches are reset (the data in the shift register is no change). All of parallel conversion outputs are "L". |
|  | H | H | The serial data into the DATA terminal are inputted to the shift register. In this stage, the data in the latch is not changed. |
| L | L | H | The data in the shift register is transferred to the latch. And the data in the latch is output from the parallel conversion output terminals. |
| H | | | |
|  | | | |
| | | | When the clock signal is inputted into the CLK terminal in state of the $\overline{\text{STB}}="L"$ and $\overline{\text{CLR}}="H"$, the data is shifted in the shift register and latched data is also changed in accordance with the shift register. |

Note 1) X: Don't care

■ TIMING CHART

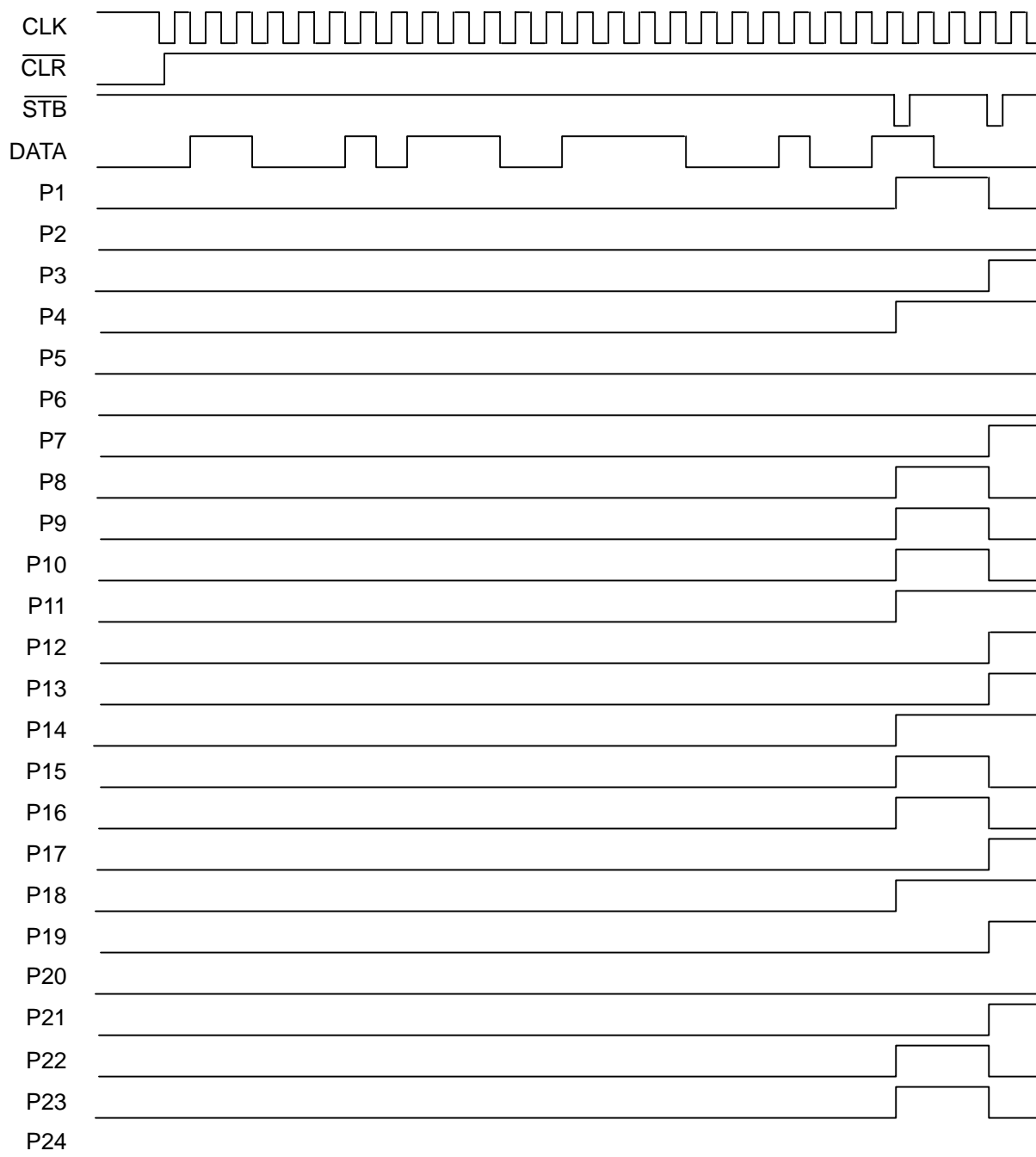

■ ABSOLUTE MAXIMUM RATINGS

(Ta=25°C)

| PARAMETER | SYMBOL | RATINGS | | UNIT |
|--|------------------|---|-----------|------|
| Supply Voltage Range | V _{DD} | -0.5 ~ +7.0 | | V |
| Input Voltage Range | V _I | V _{SS} -0.5 ~ V _{DD} +0.5 | | V |
| Output Voltage Range | V _O | V _{SS} -0.5 ~ V _{DD} +0.5 | | V |
| Output Current | I _O | ±25 | | mA |
| Output Short Current (P1~P24 Terminals) (Note 5) | I _{OSD} | V _O =7V, V _I =0V | 20 (max) | mA |
| | | V _O =0V, V _I =7V | -20 (max) | |
| Power Dissipation | P _D | 800 (SSOP) (Note 6) | | mW |
| Operating Temperature Range | Topr | -25 ~ +85 | | °C |
| Storage Temperature Range | Tstg | -65 ~ +150 | | °C |

Note 2) All voltage are relative to V_{SS}=0V reference.

Note 3) Do not exceed the absolute maximum ratings, otherwise the stress may cause a permanent damage to the IC. It is also recommended that the IC be used in the range specified in the DC electrical characteristics, or the electrical stress may cause malfunctions and impact on the reliability.

Note 4) To stabilize the IC operation, place decoupling capacitor between V_{DD} and V_{SS}.

Note 5) V_{DD}=7V, V_{SS}=0V, less than 1 second per pin.

Note 6) EIA/JEDEC Standard Test Board (76.2 x 114.3 x 1.6mm, 2layers, FR-4) mounting.

■ DC ELECTRICAL CHARACTERISTICS

(V_{DD}=2.4~5.5V, V_{SS}=0V, Ta=25°C, unless otherwise noted)

| PARAMETER | SYMBOL | CONDITION | | MIN | TYP | MAX | UNIT | |
|---------------------------------------|------------------|---|------------------------|---------------------|----------------------|--------------------|-----------------|---|
| Operating Voltage | V _{DD} | | | 2.4 | - | 5.5 | V | |
| Operating Current | I _{DDs} | V _{IH} =V _{DD} , V _{IL} =V _{SS} | | - | - | 0.1 | mA | |
| High-level Input Voltage | V _{IH} | | | 0.7V _{DD} | - | V _{DD} | V | |
| Low-level Input Voltage | V _{IL} | | | V _{SS} | - | 0.3V _{DD} | V | |
| Input Leakage Current | I _{LI} | V _I =0~V _{DD} | | -10 | - | 10 | µA | |
| High-level Output Voltage (Note 7) | V _{OHD} | V _{DD} =5V | I _{OH} =-25mA | P1~P24 Terminals | V _{DD} -1.5 | - | V _{DD} | V |
| | | | I _{OH} =-15mA | | V _{DD} -1.0 | - | V _{DD} | |
| | | | I _{OH} =-10mA | | V _{DD} -0.5 | - | V _{DD} | |
| | | V _{DD} =3V | I _{OH} =-5mA | | V _{DD} -0.5 | - | V _{DD} | |
| Low-level Output Voltage (Note 7) | V _{OLD} | V _{DD} =5V | I _{OL} =+25mA | P1~P24 Terminals | V _{SS} | - | 1.5 | V |
| | | | I _{OL} =+15mA | | V _{SS} | - | 0.8 | |
| | | | I _{OL} =+10mA | | V _{SS} | - | 0.4 | |
| | | V _{DD} =3V | I _{OL} =+5mA | | V _{SS} | - | 0.5 | |

Note 7) Specified value represent output current per pin. When use, total current consideration and less than power dissipation in rating operation should be required.

NJU3719A

■ SWITCHING CHARACTERISTICS

($V_{DD}=2.4\sim 5.5V$, $V_{SS}=0V$, $T_a=25^{\circ}C$, unless otherwise noted)

| PARAMETER | SYMBOL | CONDITION | MIN | TYP | MAX | UNIT |
|-----------------------------|----------------|--------------------------|-----|-----|-----|------|
| Set-Up Time | t_{SD} | DATA-CLK | 20 | - | - | ns |
| Hold Time | t_{HD} | CLK-DATA | 20 | - | - | ns |
| Set-Up Time | t_{SSTB} | \overline{STB} -CLK | 30 | - | - | ns |
| Hold Time | t_{HSTB} | CLK- \overline{STB} | 30 | - | - | ns |
| Output Delay Time | $t_{pd\ PCK}$ | CLK-P1~P24 | - | - | 100 | ns |
| | $t_{pd\ PSTB}$ | \overline{STB} -P1~P24 | - | - | 80 | ns |
| | $t_{pd\ PCLR}$ | \overline{CLR} -P1~P24 | - | - | 80 | ns |
| Maximum Operating Frequency | f_{MAX} | | 5 | - | - | MHz |

Note 8) $C_{OUT}=50pF$

SWITCHING CHARACTERISTICS TEST WAVEFORM

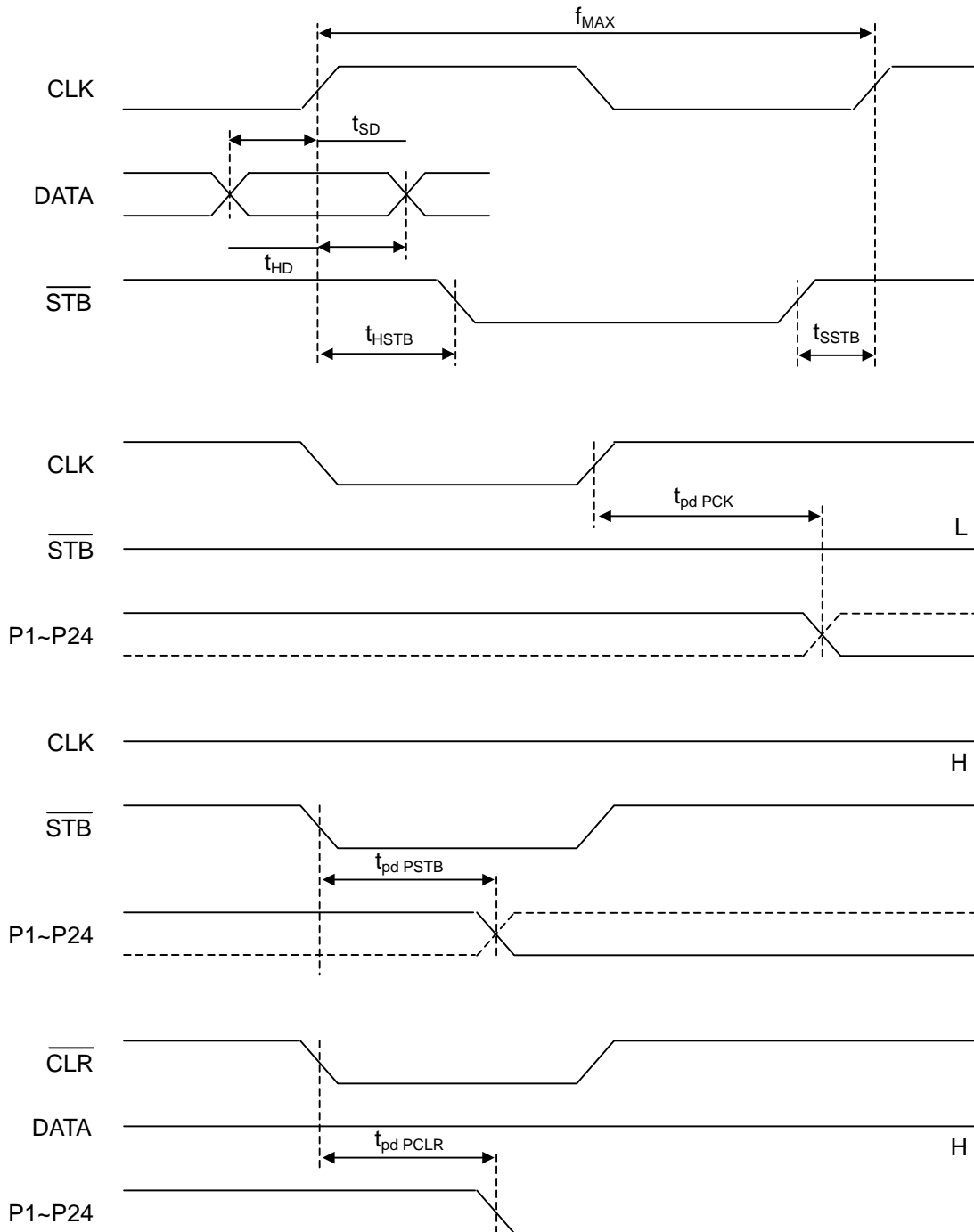

NJU3719A

■ APPLICATION CIRCUIT

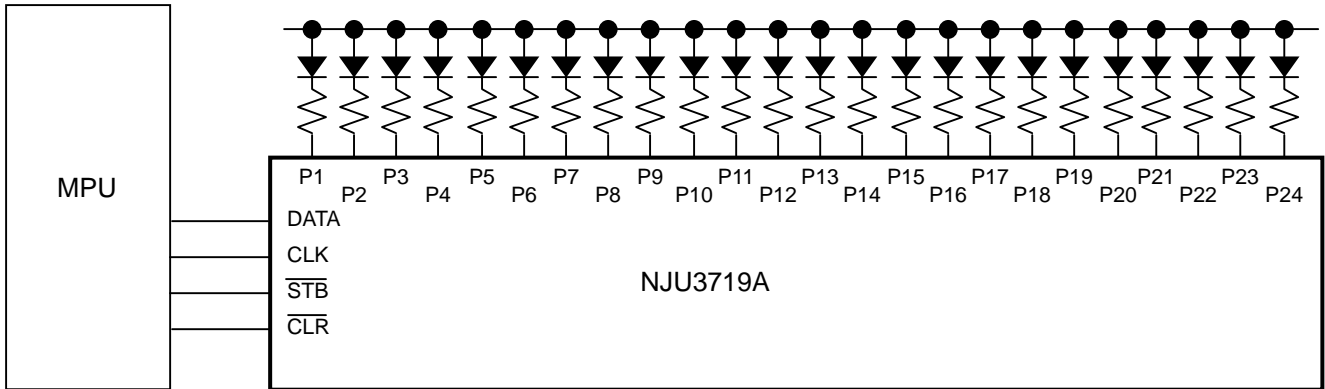

[CAUTION]
The specifications on this databook are only given for information, without any guarantee as regards either mistakes or omissions. The application circuits in this databook are described only to show representative usages of the product and not intended for the guarantee or permission of any right including the industrial rights.

Mouser Electronics

Authorized Distributor

Click to View Pricing, Inventory, Delivery & Lifecycle Information:

[NJR:](#)

[NJU3719L](#) [NJU3719AM](#) [NJU3719AM-TE2](#) [NJU3719AM-TE1](#)

Данный компонент на территории Российской Федерации

Вы можете приобрести в компании MosChip.

Для оперативного оформления запроса Вам необходимо перейти по данной ссылке:

<http://moschip.ru/get-element>

Вы можете разместить у нас заказ для любого Вашего проекта, будь то серийное производство или разработка единичного прибора.

В нашем ассортименте представлены ведущие мировые производители активных и пассивных электронных компонентов.

Нашей специализацией является поставка электронной компонентной базы двойного назначения, продукции таких производителей как XILINX, Intel (ex.ALTERA), Vicor, Microchip, Texas Instruments, Analog Devices, Mini-Circuits, Amphenol, Glenair.

Сотрудничество с глобальными дистрибьюторами электронных компонентов, предоставляет возможность заказывать и получать с международных складов практически любой перечень компонентов в оптимальные для Вас сроки.

На всех этапах разработки и производства наши партнеры могут получить квалифицированную поддержку опытных инженеров.

Система менеджмента качества компании отвечает требованиям в соответствии с ГОСТ Р ИСО 9001, ГОСТ РВ 0015-002 и ЭС РД 009

Офис по работе с юридическими лицами:

105318, г.Москва, ул.Щербаковская д.3, офис 1107, 1118, ДЦ «Щербаковский»

Телефон: +7 495 668-12-70 (многоканальный)

Факс: +7 495 668-12-70 (доб.304)

E-mail: info@moschip.ru

Skype отдела продаж:

moschip.ru

moschip.ru_4

moschip.ru_6

moschip.ru_9