

601-CS-D-P1

Monitors a zero-sequence CT for high accuracy ground fault protection



Description

The 601-CS-D-P1 3-phase power monitor is a fully programmable electronic power monitor designed to monitor 3-phase systems. The 601-CS-D-P1 has a single relay that can be configured as a general purpose network output or to trip on ground faults. The 601-CS-D-P1 monitors ground fault current, phase currents, phase voltages, power factor and frequency. The RS485MS-2W communications module allows the 601-CS-D-P1 to communicate using the Modbus RTU protocol. The Modbus connection can be used to monitor power parameters, setup the device or control the fault relay. A DeviceNet™ communications I/O module (CIO-601CS-DN-P1) is available as well. This CIO module only works with the 601-CS-D-P1 unit. It is used for sending the information from the 601-CS-D-P1 over a DeviceNet™ network. It also provides I/O capabilities and the ability to set the parameters of the 601-CS-D-P1.

Note: This product must be used with an external Zero-Sequence CT for proper operation (not included).

Wiring Diagram

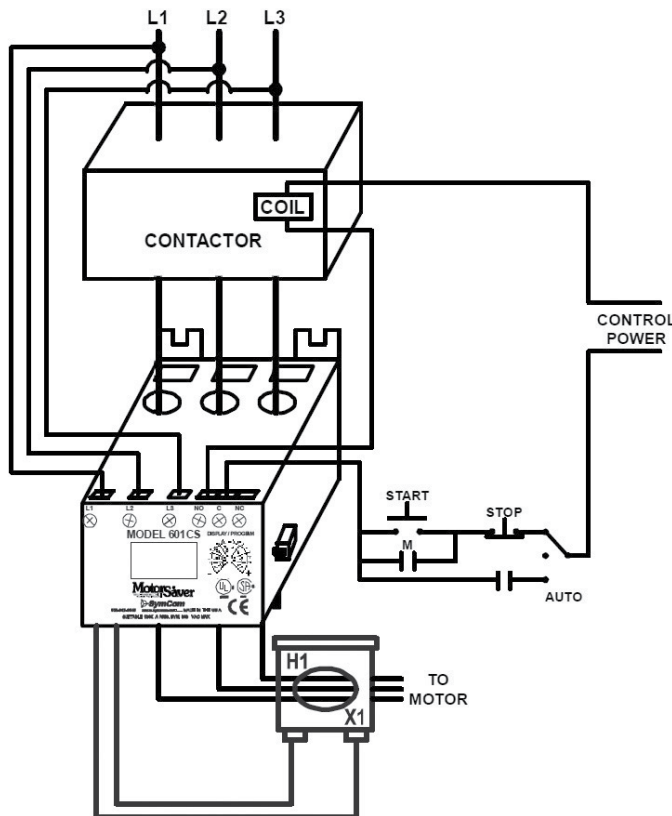

Features & Benefits

FEATURES	BENEFITS
Built-in display	Visual indication for programming and viewing real-time parameters for nominal voltage, voltage unbalance, current, current unbalance, ground fault warning, ground fault trip, and ground fault motor acceleration
15 Programmable parameters to control the device operation	Allows the user to customize the protection required for their system
2 programmable trip delay timers	Program separate trip delay time for motor acceleration and ground fault
Network communications capability	Compatible with Modbus RTU and DeviceNet™ protocols with the use of separate communications module

Accessories

CIO-601CS-DN-P1 Module
Convenient, cost-effective DeviceNet™ interface device capable of providing discrete control and monitoring of motor starters, drives and other devices over a DeviceNet™ network.



601-CS-D-P1

Specifications

Input Characteristics

Line Voltage	200-480VAC
Frequency	50/60Hz
Motor Full Load Amp Range	0.5-175A (direct) 176-800A (CTs required)
Input Ground Fault Current	0.5-10A

Output Characteristics

Output Contact Rating (SPDT)	
Pilot Duty	480VA @ 240VAC
General Purpose	10A @ 240VAC
Expected Life	
Mechanical	1 x 10 ⁶ operations
Electrical	1 x 10 ⁵ operations at rated load

General Characteristics

Ambient Temperature Range	
Operating	-20° to 70°C (-4° to 158°F)
Storage	-40° to 80°C (-40° to 176°F)
Accuracy at 25° C (77° F)	
Voltage	+/-1%
Current	+/-3% (<175A direct)
GF Current	+/-3%
Repeatability	
Voltage	+/-0.5% of nominal voltage
Current	+/-1% (<175A direct)
Maximum Input Power	10 W
Pollution Degree	3
Class of Protection	IP20
Relative Humidity	10-95%, non-condensing per IEC 68-2-3
Terminal Torque	7in.-lbs.

Standards Passed

Electrostatic Discharge (ESD)	IEC 61000-4-2, Level 3, 6kV contact, 8kV air
Radio Frequency Immunity, Conducted	IEC 61000-4-6, Level 3 10V
Radio Frequency Immunity, Radiated	IEC 61000-4-3, Level 3, 10 V/m
Fast Transient Burst	IEC 61000-4-4, Level 3, 3.5kV input power
Short Circuit Rating	100kA rms, SYM, 600VAC max.
Surge Immunity IEC	IEC 61000-4-5, Level 3, 2kV line-to-line; Level 4, 4kV line-to-ground
ANSI/IEEE	C62.41 Surge and Ring Wave Compliance to a level of 6kV line-to-line
High Potential Test	Meets UL508 (2 x rated V +1000V for 1 minute)
Safety Marks	
UL	UL508 (File #E68520)
CE	IEC 60947-1, IEC 60947-5-1
Max Conductor Size (with insulation)	0.65"
Dimensions	H 77.47 mm (3.05"); W 97.79 mm (3.85"); D 128.27 mm (5.05")
Weight	1.2 lbs. (19.2 oz., 544.31 g)
Mounting Method	Surface mount (4 - #8 screws) or DIN rail mount

Данный компонент на территории Российской Федерации

Вы можете приобрести в компании MosChip.

Для оперативного оформления запроса Вам необходимо перейти по данной ссылке:

<http://moschip.ru/get-element>

Вы можете разместить у нас заказ для любого Вашего проекта, будь то серийное производство или разработка единичного прибора.

В нашем ассортименте представлены ведущие мировые производители активных и пассивных электронных компонентов.

Нашей специализацией является поставка электронной компонентной базы двойного назначения, продукции таких производителей как XILINX, Intel (ex.ALTERA), Vicor, Microchip, Texas Instruments, Analog Devices, Mini-Circuits, Amphenol, Glenair.

Сотрудничество с глобальными дистрибьюторами электронных компонентов, предоставляет возможность заказывать и получать с международных складов практически любой перечень компонентов в оптимальные для Вас сроки.

На всех этапах разработки и производства наши партнеры могут получить квалифицированную поддержку опытных инженеров.

Система менеджмента качества компании отвечает требованиям в соответствии с ГОСТ Р ИСО 9001, ГОСТ РВ 0015-002 и ЭС РД 009

Офис по работе с юридическими лицами:

105318, г.Москва, ул.Щербаковская д.3, офис 1107, 1118, ДЦ «Щербаковский»

Телефон: +7 495 668-12-70 (многоканальный)

Факс: +7 495 668-12-70 (доб.304)

E-mail: info@moschip.ru

Skype отдела продаж:

moschip.ru

moschip.ru_4

moschip.ru_6

moschip.ru_9