

FEATURES

Qualified for automotive applications

6th-order performance, low-pass video filter

1 dB flatness out to 8 MHz

50 dB rejection at 27 MHz

Ultralow power-down current: 0.1 μ A typical

Low quiescent current: 1.85 mA typical

Excellent video specification

Differential gain: 0.25%

Differential phase: 0.10°

SAG correction

Allows use of small capacitors in ac-coupled outputs

Low supply voltage: 2.5 V to 6 V

Rail-to-rail output

High input-to-output isolation in disabled state

92 dB at 1 MHz

Low input bias current: 0.5 μ A

Small packaging: SC70 and SOT-23 (automotive grade only)

Wide operating temperature range: -40°C to +125°C

APPLICATIONS

Automotive infotainment (SOT-23 only)

Automotive rearview cameras (SOT-23 only)

Portable media players

Portable gaming consoles

Cell phones

Digital still cameras

Portable DVD players

Portable video cameras

GENERAL DESCRIPTION

The ADA4430-1 is a fully integrated video reconstruction filter that combines excellent video specifications with low power consumption and an ultralow power disable, making it ideal for portable video filtering applications. With 1 dB frequency flatness out to 8 MHz and 50 dB rejection at 27 MHz, the ADA4430-1 is ideal in SD video applications, including NTSC and PAL.

The ADA4430-1 operates on single supplies as low as 2.5 V and as high as 6 V while providing the dynamic range required by the most demanding video systems.

PIN CONFIGURATION

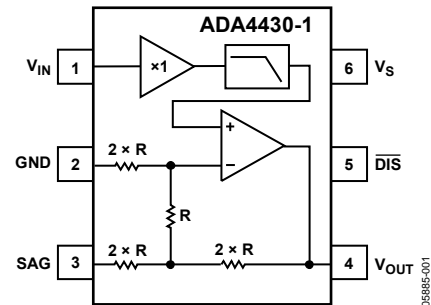

Figure 1.

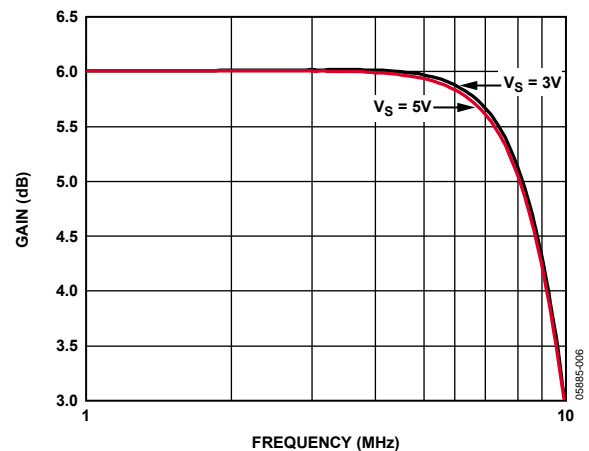

Figure 2. Frequency Response Flatness at Various Power Supplies

The ADA4430-1 also provides an on-chip dc offset to avoid clipping of the sync tips at the filter output, as well as SAG correction that permits smaller capacitor values to be used in applications with ac-coupled outputs.

The ADA4430-1 is available in a two 6-lead packages. The SC70 for commercial applications and the SOT-23 for automotive applications are rated to work in the extended temperature range of -40°C to +125°C.

Rev. C

Information furnished by Analog Devices is believed to be accurate and reliable. However, no responsibility is assumed by Analog Devices for its use, nor for any infringements of patents or other rights of third parties that may result from its use. Specifications subject to change without notice. No license is granted by implication or otherwise under any patent or patent rights of Analog Devices. Trademarks and registered trademarks are the property of their respective owners.

TABLE OF CONTENTS

Features	1	Theory of Operation	12
Applications.....	1	Overview	12
Pin Configuration.....	1	Power Savings Using the ADA4430-1	12
General Description	1	Applications Information	13
Revision History	2	Examples Illustrating Output Coupling.....	13
Specifications.....	3	Usable Input Voltage Range	14
Absolute Maximum Ratings.....	5	SAG Correction Frequency Response.....	14
Thermal Resistance	5	Reconstruction Filter Applications	15
ESD Caution.....	5	Printed Circuit Board Layout	16
Pin Configuration and Function Descriptions.....	6	Outline Dimensions.....	17
Typical Performance Characteristics	7	Ordering Guide	18
Test Circuits.....	11	Automotive Products.....	18

REVISION HISTORY

9/10—Rev. B to Rev. C

Change Automotive Products Section Heading.....	18
---	----

6/10—Rev. A to Rev. B

Updated Pin Name \overline{PD} to \overline{DIS} Throughout.....	1
Added 6-Lead SOT-23	Universal
Changes to Features Section, General Description Section, Applications Section, and Figure 1.....	1
Changes to Table 1.....	3
Changes to Table 2.....	4
Changes to Table 4, Maximum Power Dissipation Section, and Figure 3	5
Changes to Figure 4 and Table 5.....	6
Changes to Figure 16.....	8

Changes to Figure 25 and Figure 26.....	11
Changes to Overview Section.....	12
Changes to Figure 29, Figure 30, and Figure 31	13
Changes to Figure 33 and Figure 34.....	15
Added Figure 36; Renumbered Sequentially	17
Updated Outline Dimensions.....	17
Changes to Ordering Guide	18
Added Automotive Products Section	18

6/06—Rev. 0 to Rev. A

Changes to Figure 1.....	1
Changes to Figure 4.....	5

3/06—Revision 0: Initial Version

SPECIFICATIONS

$V_S = 3\text{ V}$ @ $T_A = 25^\circ\text{C}$, $V_{IN} = 1\text{ V p-p}$, $R_L = 150\ \Omega$, unless otherwise noted.

Table 1.

Parameter	Test Conditions/Comments	Min	Typ	Max	Unit
ELECTRICAL SPECIFICATIONS					
Quiescent Supply Current			1.85	2.3	mA
Quiescent Supply Current	ADA4430-1W only: T_{MIN} to T_{MAX}		1.85	3	mA
Quiescent Supply Current—Disabled			0.1	5	μA
Quiescent Supply Current—Disabled	ADA4430-1W only: T_{MIN} to T_{MAX}		0.1	6	μA
Supply Voltage	ADA4430-1W only: T_{MIN} to T_{MAX}	2.5		6	V
Input Voltage Range—Low/High	Limited by output range; see the Applications Information section		0/1.38		V
Input Resistance			10		M Ω
Input Capacitance			1		pF
Input Bias Current			0.5		μA
Output Voltage Range—Low/High			0.10/2.85		V
Output Offset Voltage			95	140	mV
Output Offset Voltage	ADA4430-1W only: T_{MIN} to T_{MAX}		95	200	mV
PSRR	Input referred, ADA4430-1W only: T_{MIN} to T_{MAX}	50	60		dB
Pass-Band Gain	ADA4430-1W only: T_{MIN} to T_{MAX}	5.85	6		dB
Input-to-Output Isolation—Disabled	$f = 1\text{ MHz}$		92		dB
FILTER CHARACTERISTICS					
–3 dB Bandwidth	ADA4430-1W only: T_{MIN} to T_{MAX}	7	9.7		MHz
1 dB Flatness	ADA4430-1W only: T_{MIN} to T_{MAX}	5.5	8.0		MHz
Out-of-Band Rejection	$f = 27\text{ MHz}$; ADA4430-1W only: T_{MIN} to T_{MAX}	40	50		dB
Differential Gain	Modulated 10-step ramp, sync tip at 0 V		0.25		%
Differential Phase	Modulated 10-step ramp, sync tip at 0 V		0.10		Degrees
Linear Output Current			40		mA
Group Delay Variation	$f = 100\text{ kHz}$ to 5 MHz		7		ns
Signal-to-Noise Ratio	100% white signal, $f = 100\text{ kHz}$ to 5 MHz		76		dB
DISABLE					
Disable Input Voltage	Device disabled		<0.7		V
	Device enabled		>1.1		V

ADA4430-1

$V_S = 5\text{ V}$ @ $T_A = 25^\circ\text{C}$, $V_{IN} = 1\text{ V p-p}$, $R_L = 150\ \Omega$, unless otherwise noted.

Table 2.

Parameter	Test Conditions/Comments	Min	Typ	Max	Unit
ELECTRICAL SPECIFICATIONS					
Quiescent Supply Current			2.0	2.4	mA
Quiescent Supply Current	ADA4430-1W only: T_{MIN} to T_{MAX}		2.0	3.1	mA
Quiescent Supply Current—Disabled			0.2	10	μA
Quiescent Supply Current—Disabled	ADA4430-1W only: T_{MIN} to T_{MAX}		0.2	15	μA
Supply Voltage	ADA4430-1W only: T_{MIN} to T_{MAX}	2.5		6	V
Input Voltage Range—Low/High	Limited by output range; see the Applications Information section		0/2.35		V
Input Resistance			10		M Ω
Input Capacitance			1		pF
Input Bias Current			0.5		μA
Output Voltage Range—Low/High			0.10/4.80		V
Output Offset Voltage			100	145	mV
Output Offset Voltage	ADA4430-1W only: T_{MIN} to T_{MAX}		100	200	mV
PSRR	Input referred, ADA4430-1W only: T_{MIN} to T_{MAX}	50	61		dB
Pass-Band Gain	ADA4430-1W only: T_{MIN} to T_{MAX}	5.85	6		dB
Input-to-Output Isolation—Disabled	$f = 1\text{ MHz}$		92		dB
FILTER CHARACTERISTICS					
–3 dB Bandwidth	ADA4430-1W only: T_{MIN} to T_{MAX}	7.2	9.5		MHz
1 dB Flatness	ADA4430-1W only: T_{MIN} to T_{MAX}	5.5	7.9		MHz
Out-of-Band Rejection	$f = 27\text{ MHz}$, ADA4430-1W only: T_{MIN} to T_{MAX}	40	50		dB
Differential Gain	Modulated 10-step ramp, sync tip at 0 V		0.25		%
Differential Phase	Modulated 10-step ramp, sync tip at 0 V		0.15		Degrees
Linear Output Current			40		mA
Group Delay Variation	$f = 100\text{ kHz}$ to 5 MHz		7.1		ns
Signal-to-Noise Ratio	100% white signal, $f = 100\text{ kHz}$ to 5 MHz		76		dB
DISABLE					
Disable Input Voltage	Device disabled		<0.8		V
	Device enabled		>1		V

ABSOLUTE MAXIMUM RATINGS

Table 3.

Parameter	Rating
Supply Voltage	6 V
Power Dissipation	See Figure 3
Storage Temperature Range	-65°C to +125°C
Operating Temperature Range	-40°C to +125°C
Lead Temperature (Soldering 10 sec)	300°C
Junction Temperature	150°C

Stresses above those listed under Absolute Maximum Ratings may cause permanent damage to the device. This is a stress rating only; functional operation of the device at these or any other conditions above those indicated in the operational section of this specification is not implied. Exposure to absolute maximum rating conditions for extended periods may affect device reliability.

THERMAL RESISTANCE

θ_{JA} is specified for the worst-case conditions, that is, θ_{JA} is specified for a device soldered in the circuit board.

Table 4. Thermal Resistance

Package Type	θ_{JA}	Unit
6-Lead SC70	430	°C/W
6-Lead SOT-23	170	°C/W

Maximum Power Dissipation

The maximum safe power dissipation in the ADA4430-1 package is limited by the associated rise in junction temperature (T_J) on the die. At approximately 150°C, which is the glass transition temperature, the plastic changes its properties. Even temporarily exceeding this temperature limit can change the stresses that the package exerts on the die, permanently shifting the parametric performance of the ADA4430-1. Exceeding a junction temperature of 150°C for an extended period can result in changes in the silicon devices, potentially causing failure.

The power dissipated in the package (P_D) is the sum of the quiescent power dissipation and the power dissipated in the package due to the load drive. The quiescent power is the voltage between the supply pins (V_S) times the quiescent current (I_S). The power dissipated due to the load drive depends upon the particular application. The power due to load drive is calculated by multiplying the load current by the associated voltage drop across the device. RMS voltages and currents must be used in these calculations.

Airflow increases heat dissipation, effectively reducing θ_{JA} . In addition, more metal directly in contact with the package leads from metal traces, through holes, ground, and power planes reduces the θ_{JA} .

Figure 3 shows the maximum safe power dissipation in the package vs. the ambient temperature for the 6-lead SC70 (430°C/W) and the 6-lead SOT-23 (170°C/W) on a JEDEC standard 4-layer board.

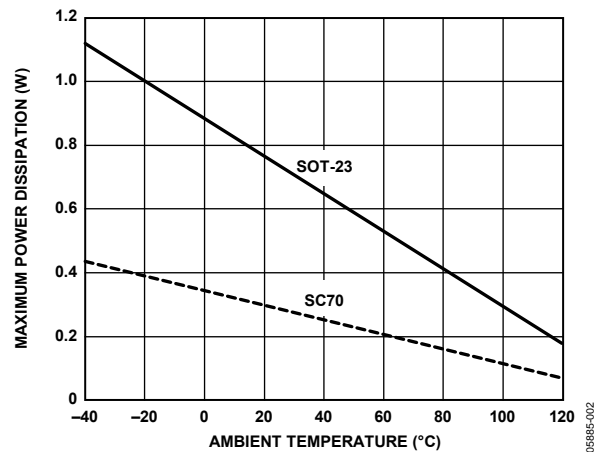

Figure 3. Maximum Power Dissipation vs. Temperature for a 4-Layer Board

ESD CAUTION



ESD (electrostatic discharge) sensitive device. Charged devices and circuit boards can discharge without detection. Although this product features patented or proprietary protection circuitry, damage may occur on devices subjected to high energy ESD. Therefore, proper ESD precautions should be taken to avoid performance degradation or loss of functionality.

ADA4430-1

PIN CONFIGURATION AND FUNCTION DESCRIPTIONS

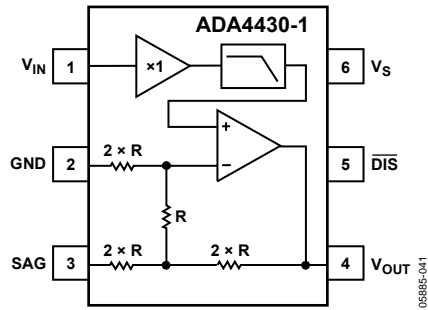

Figure 4. 6-Lead SC70 and SOT23 Top View

Table 5. Pin Function Descriptions

Pin Number	Mnemonic	Description
1	V_{IN}	Input Voltage.
2	GND	Ground.
3	SAG	Feedback Connection.
4	V_{OUT}	Output Voltage.
5	\overline{DIS}	Disable.
6	V_S	Positive Power Supply.

TYPICAL PERFORMANCE CHARACTERISTICS

$V_S = 3\text{ V}$, $R_L = 150\ \Omega$, $V_{OUT} = 2.0\text{ V p-p}$, $\overline{DIS} = \text{high}$, V_{OUT} connected directly to SAG, $T_A = 25^\circ\text{C}$, unless otherwise noted.

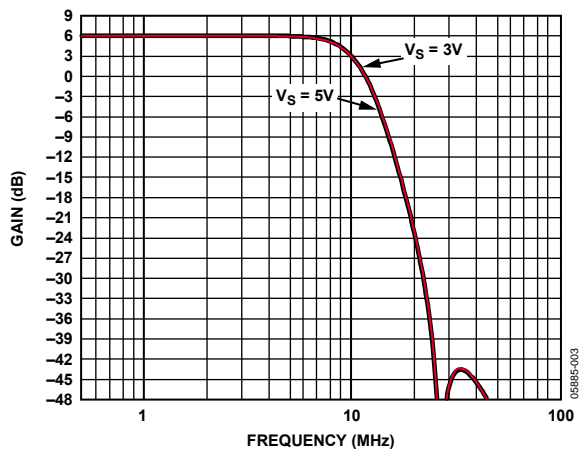

Figure 5. Frequency Response at Various Power Supplies

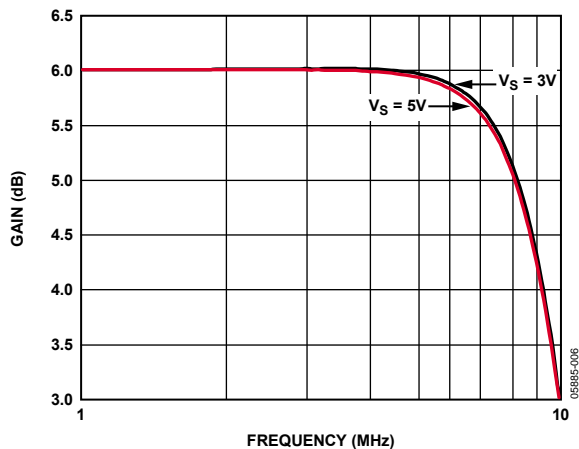

Figure 8. Frequency Response Flatness at Various Power Supplies

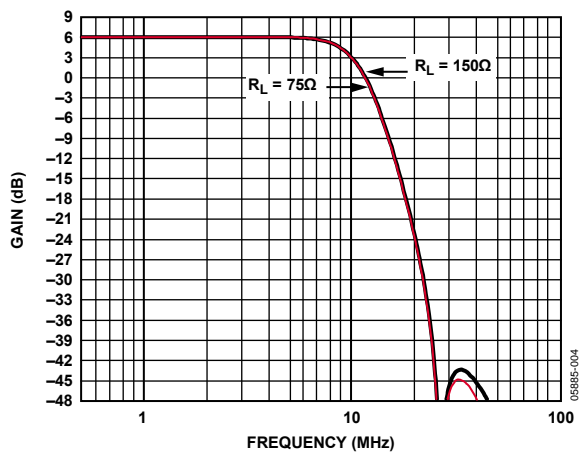

Figure 6. Frequency Response at Various Loads

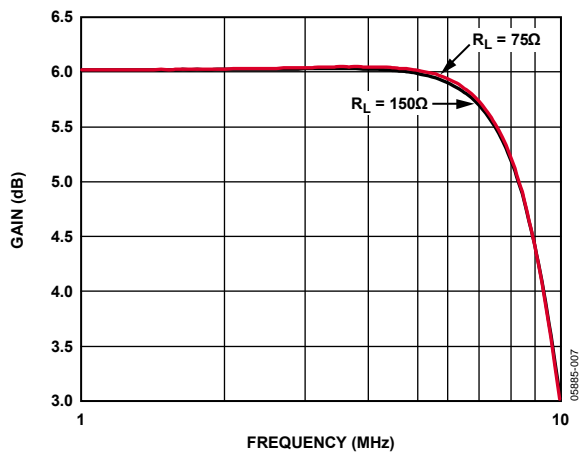

Figure 9. Frequency Response Flatness at Various Loads

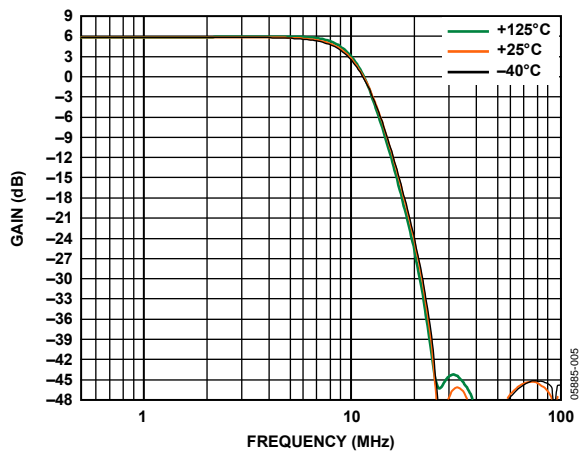

Figure 7. Frequency Response at Various Temperatures

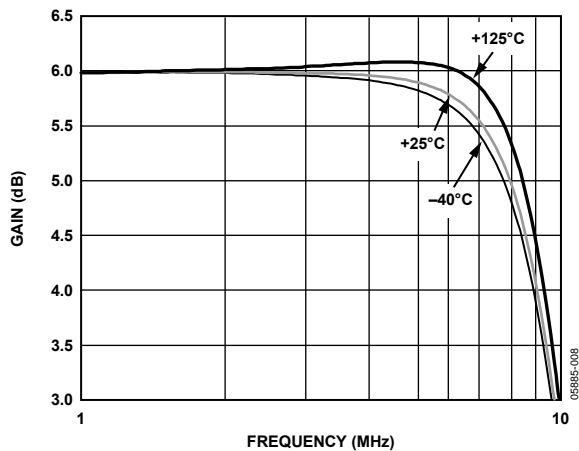

Figure 10. Frequency Response Flatness at Various Temperatures

ADA4430-1

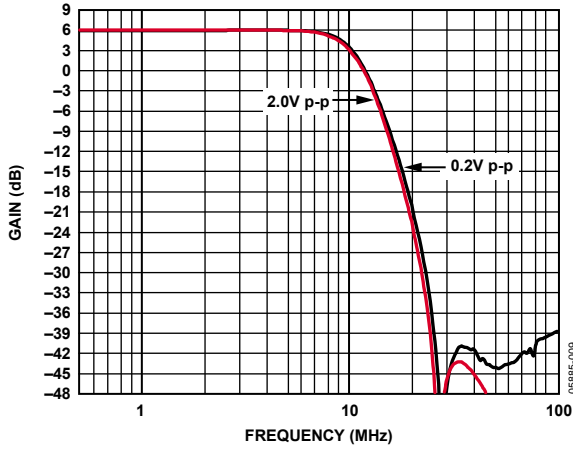

Figure 11. Frequency Response at Various Output Amplitudes

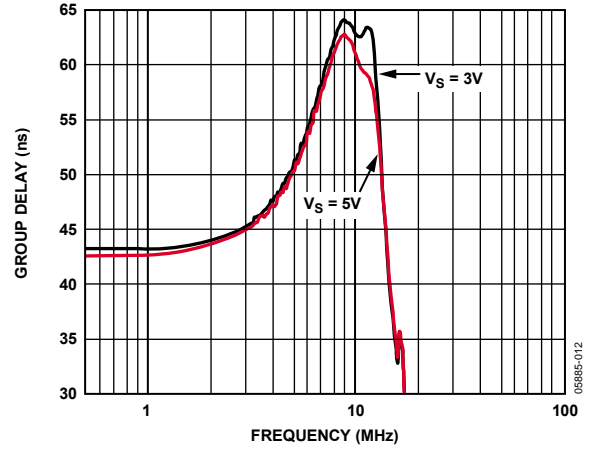

Figure 14. Group Delay at Various Power Supplies

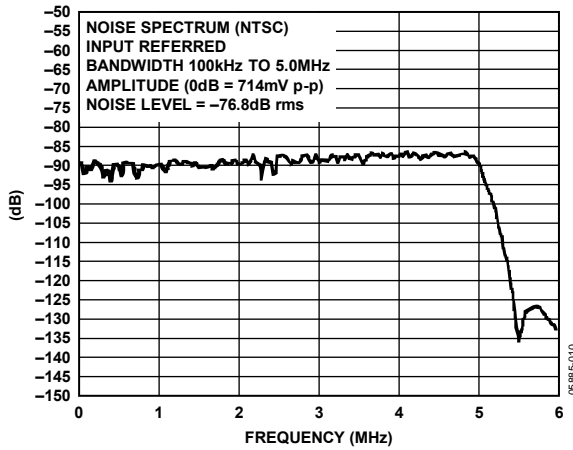

Figure 12. Input-Referred Noise Spectral Density

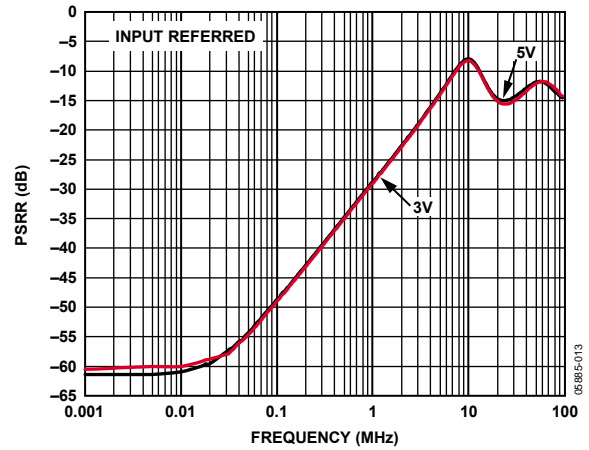

Figure 15. PSRR vs. Frequency at Various Power Supplies

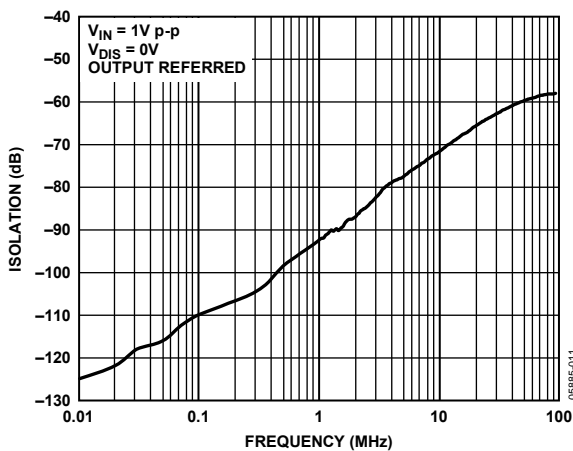

Figure 13. Input-to-Output Isolation—Disabled vs. Frequency

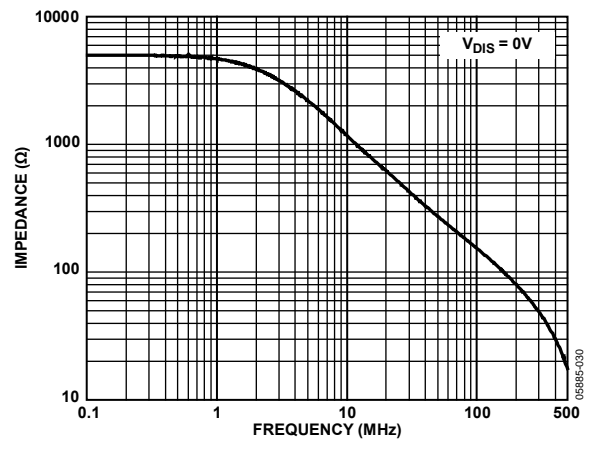

Figure 16. Disabled Output Impedance vs. Frequency



Figure 17. Transient Response

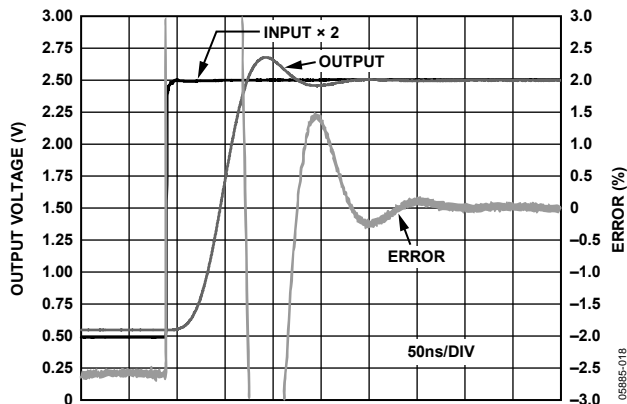

Figure 20. Settling Time

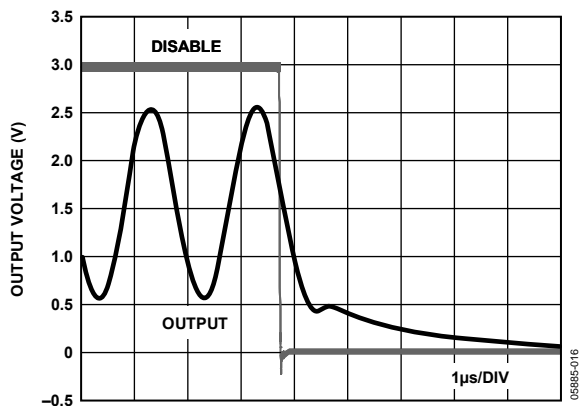

Figure 18. Disable Assert Time

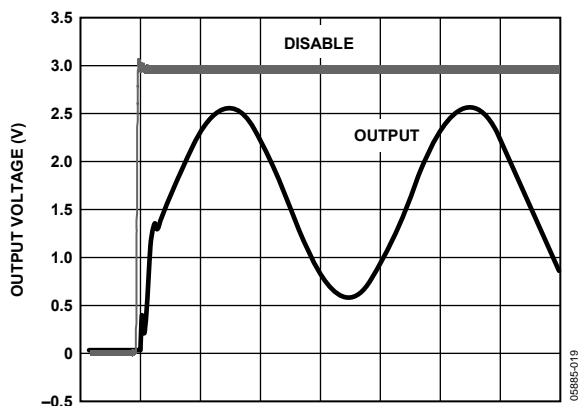

Figure 21. Disable Deassert Time



Figure 19. Overdrive Recovery

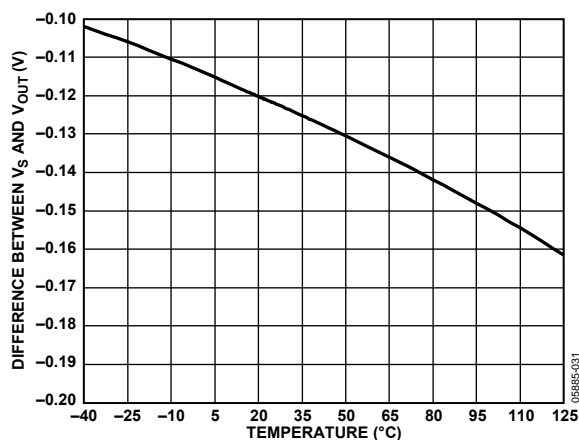

Figure 22. Output Swing Limits vs. Temperature

ADA4430-1

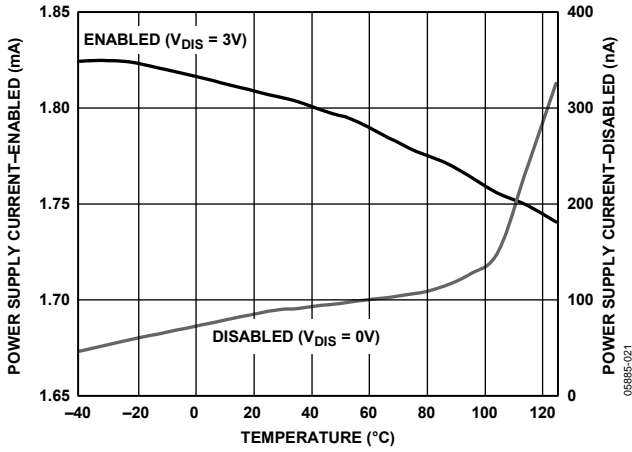

Figure 23. Power Supply Current vs. Temperature

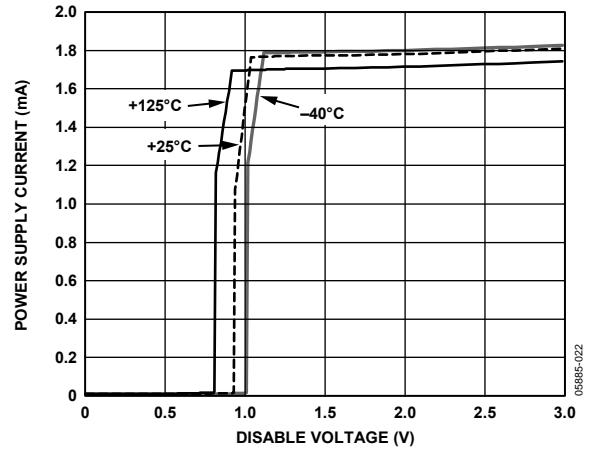

Figure 24. Power Supply Current vs. Disable Voltage at Various Temperatures

TEST CIRCUITS

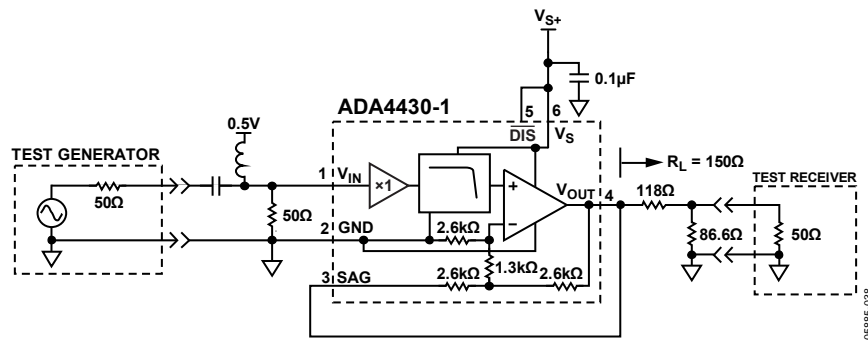

Figure 25. Test Circuit Used for Frequency Sweeps and Time-Domain Tests

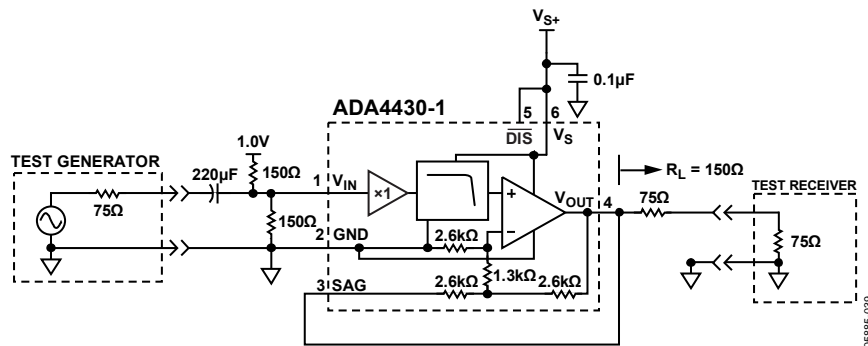

Figure 26. Test Circuit Used for Differential Gain, Differential Phase, and Noise Tests

THEORY OF OPERATION

OVERVIEW

The ADA4430-1 is designed for exceptional performance as both a filter and a low power driver for portable video applications. This performance is achieved by providing high order filtering without trading off power consumption or device size. While consuming only 1.85 mA quiescent supply current, the ADA4430-1 provides video output on a single-supply as low as 2.5 V. Such low power consumption and low supply operation normally indicates a single op amp with a two- or three-pole roll-off; however, the ADA4430-1 achieves a sixth-order roll-off in addition to a 10 M Ω input impedance for easy clamping and lower DAC output power requirements. When not in use, the ADA4430-1 can be shut down to draw less than 0.1 μ A of supply current using the disable pin (DIS). Additionally, the ADA4430-1 is unique in that it is a high order filter that fits into an SC70 package.

The ADA4430-1 provides a minimum 1 dB bandwidth of 5.5 MHz and a typical stop-band rejection of 50 dB at 27 MHz. Phase response is not sacrificed in spite of the exceptional filtering performance of the ADA4430-1, as exhibited by its group delay, which varies by only 7 ns from 100 kHz to 5 MHz.

The ADA4430-1 is intended for use in applications that have both ac- and dc-coupled inputs and outputs. The rail-to-rail buffer on the ADA4430-1 output is able to drive 2 V p-p video signals into two doubly terminated video loads (150 Ω each) on a single 2.5 V supply. The ADA4430-1 has a gain of 2 when the SAG correction pin is tied directly to the output, which makes up for the 6 dB termination loss. When the SAG feature is used (see Figure 29), the ADA4430-1 has a low frequency gain of 2.5 (\approx 8 dB) and a high frequency gain of 2. Signal offsets and supply levels must be considered when using the SAG correction feature to ensure that there are no headroom issues.

The input range of the ADA4430-1 includes ground, while the output range is limited by the saturation of the output devices. Saturation occurs several tens of mV from the positive and negative supply rails. For accurate reproduction of ground-referenced input signals, an internal offset is used to shift the output up by 95 mV.

The high input impedance and low input capacitance of the ADA4430-1 offer advantages in a number of low power applications. In reconstruction filter applications, the DAC can be placed in its lowest power mode, allowing the use of a large-valued load resistor. Using a large-valued load resistor does not interfere with the frequency response of the ADA4430-1.

The internal buffer at the ADA4430-1 input isolates the source resistance feeding the ADA4430-1 from the internal filter networks. High input impedance is also advantageous when using video clamping circuits.

The output buffer feedback network used to create a gain of 2 is connected internally to the GND pin and has a nominal impedance of 5.2 k Ω . The current required to drive this feedback network causes the overall supply current to vary based on the output level. The feedback impedance was chosen specifically to minimize excess current consumption while maintaining optimal frequency behavior.

POWER SAVINGS USING THE ADA4430-1

Using a series source termination and a shunt load termination on a low supply voltage with the ADA4430-1 realizes significant power savings compared with driving a video cable directly from a DAC output. Figure 27 shows a video DAC driving a cable directly. Properly terminating the line results in the DAC driving two 75 Ω loads and requires in excess of 30 mA to reach a full-scale level of 1.3 V. Figure 28 shows the same video load being driven using the ADA4430-1 and a series-shunt termination. This requires two times the output voltage to drive the equivalent of 150 Ω but only requires a little more than 15 mA to reach a full-scale output. When running on the same supply voltage as the DAC, this results in nearly a factor of two reduction in power compared with the circuit in Figure 27. The high level of filtering provided by the ADA4430-1 lowers the requirements on the DAC oversampling ratio, realizing further power savings. On any given DAC, 8 \times and 16 \times oversampling ratios can require twice the power consumption of a 4 \times oversampling ratio.

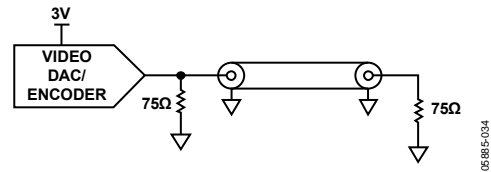

Figure 27. DAC Driving Video Cable Directly

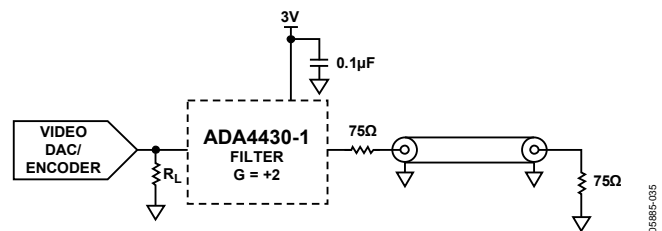

Figure 28. DAC Driving Video Cable Using the ADA4430-1

APPLICATIONS INFORMATION

EXAMPLES ILLUSTRATING OUTPUT COUPLING

The ADA4430-1 is ideally suited for use as a reconstruction filter that follows a video DAC or encoder. The application circuits in Figure 29, Figure 30, and Figure 31 illustrate a number of ways the ADA4430-1 can be used with a single-supply current-output DAC on its input and its output ac- and dc-coupled.

SAG correction allows the use of two small, lower cost capacitors in place of one large capacitor in applications with ac-coupled outputs. Circuits with ac-coupled outputs consume less power than those with dc-coupled outputs.

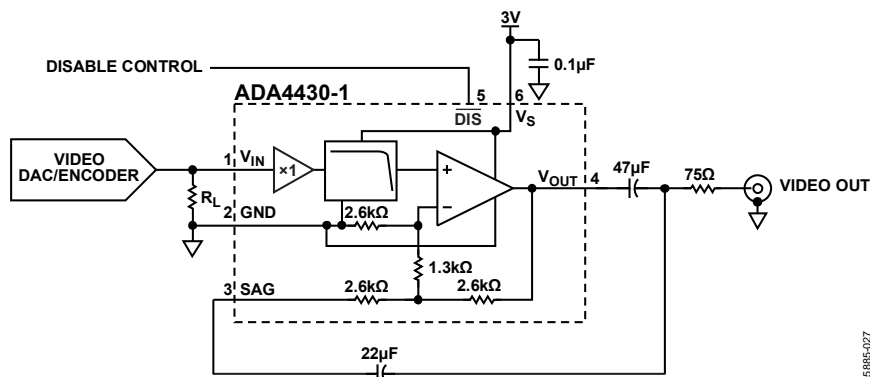

Figure 29. AC-Coupled Output with SAG Correction

05985-027

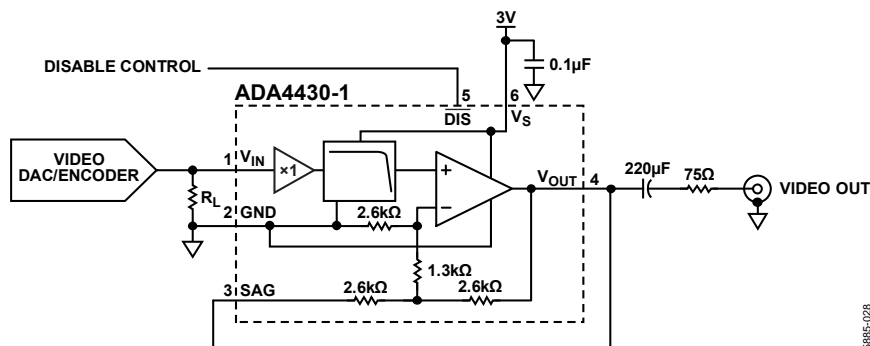

Figure 30. Traditional AC-Coupled Output with 220 μF Coupling Capacitor

05985-028

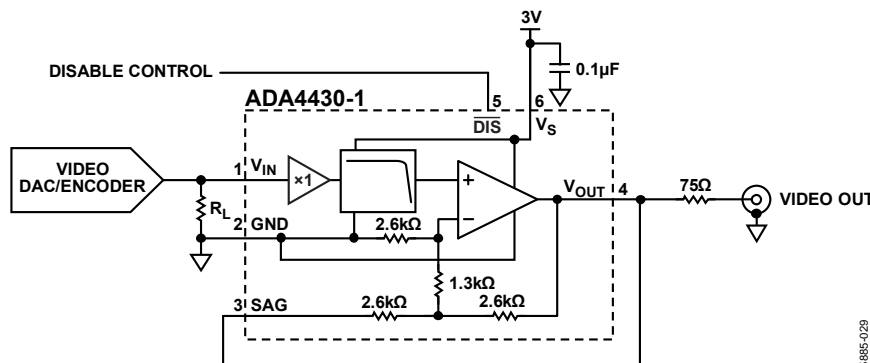

Figure 31. DC-Coupled Output

05985-029

ADA4430-1

USABLE INPUT VOLTAGE RANGE

The output voltage range of the ADA4430-1 limits its usable input voltage range. The lower end of the input range is typically 0 V. The upper end of the usable input voltage range is calculated as

$$V_{IN(max)} = (V_{OM} - V_{OO})/2$$

where:

$V_{IN(max)}$ is the upper end of the usable input voltage range.

V_{OM} is the maximum output swing.

V_{OO} is the output-referred offset voltage.

SAG CORRECTION FREQUENCY RESPONSE

When using the SAG corrected circuit, the gain from the input to the immediate output of the ADA4430-1 is $\times 2.5$ (≈ 8 dB) at extremely low frequencies where the outer feedback loop formed by the $22 \mu\text{F}$ capacitor effectively opens (see Figure 29) and exhibits a second-order peak of approximately 11 dB at about 5 Hz. This gain is approximately 7.5 dB at 30 Hz. The extra gain must be accounted for when considering low frequency input and output signal swings to keep them within their specified limits. The gain from the ADA4430-1 input to the load side of the $47 \mu\text{F}$ capacitor does not exhibit this behavior; rather, it appears more like a single-pole high-pass response. Figure 32 illustrates the SAG frequency response immediately at the ADA4430-1 output and at the load side of the $47 \mu\text{F}$ capacitor.

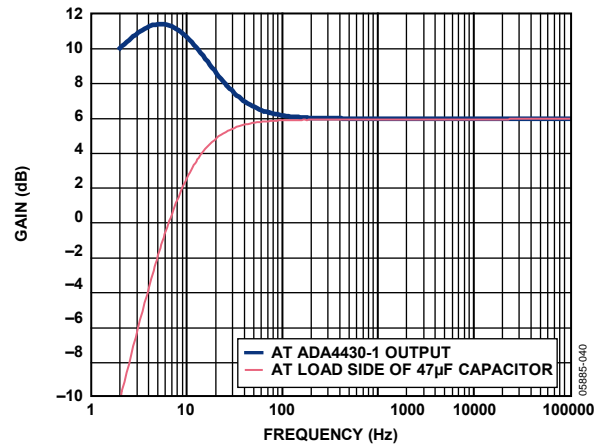

Figure 32. SAG Corrected Frequency Response at ADA4430-1 Output and at the Load Side of the $47 \mu\text{F}$ Capacitor

RECONSTRUCTION FILTER APPLICATIONS

Figure 33 illustrates how to use the ADA4430-1 as a dc-coupled reconstruction filter with a pass-band gain of 2 following the low power **ADV7190/ADV7191** video encoder. One ADV7190/ADV7191 output DAC is shown for illustrative purposes, and the remaining portions of the ADV7190/ADV7191 are omitted. The ADV7190/ADV7191 is operated in 4× oversampling mode.

The 2.4 kΩ resistor, R_{SET} , shown in Figure 33 sets the DAC output current to its minimum full-scale value of 2.16 mA, and the 600 Ω load resistor produces a full-scale voltage of 1.296 V at the ADA4430-1 input.

Figure 34 illustrates another reconstruction filter application, following the **ADV7174** video encoder. As in Figure 33, one **ADV7174** output DAC is shown for illustrative purposes, and the remaining portions of the ADV7174 are omitted.

The 1041 Ω resistor, R_{SET} , shown in Figure 34, sets the DAC output current to its minimum full-scale value of 5 mA, and the 262.5 Ω load resistor produces a full-scale voltage of 1.313 V at the ADA4430-1 input.

The ADV7174 can produce a maximum full-scale DAC output current of approximately 35 mA and is therefore capable of driving the video cable directly; however, as shown in Figure 34, the ADA4430-1 offers a lower power cable-driving option.

Figure 34 reveals the details of how the ADA4430-1 saves power when driving video cables with terminations at both ends. A full-scale level at the DAC output produces 2.626 V at the ADA4430-1 output, which in turn delivers 17.5 mA into the cable. In the case shown in Figure 27, the output voltage is 1.313 V, but the current driven into the cable is 35 mA—twice that required when the ADA4430-1 is used. Therefore, the ADA4430-1 allows the video encoder to be operated at its minimum full-scale output current, and it efficiently handles the cable-driving burden.

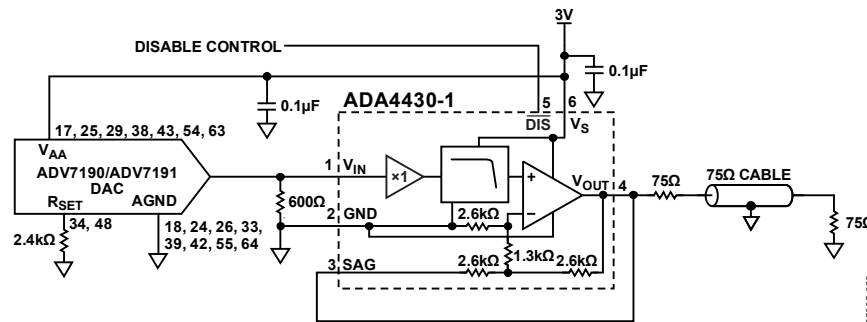

Figure 33. Using the ADA4430-1 with the ADV7190/ADV7191 Video Encoder

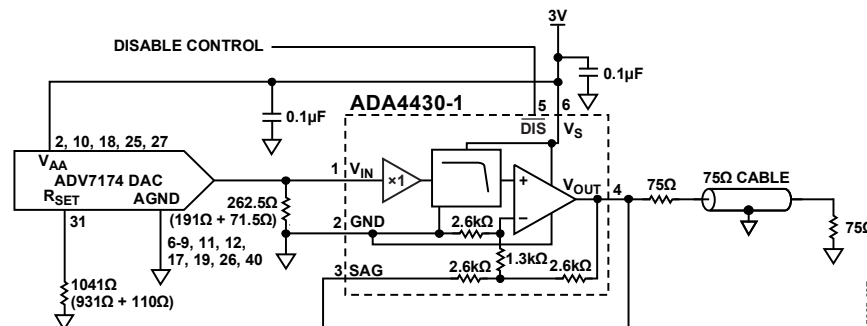

Figure 34. Using the ADA4430-1 with the ADV7174 Video Encoder

ADA4430-1

PRINTED CIRCUIT BOARD LAYOUT

As with all high speed applications, attention to printed circuit board layout is of paramount importance. Standard high speed layout practices should be adhered to when designing with the ADA4430-1. A solid ground plane is recommended, and a 0.1 μF surface-mount, ceramic power supply, decoupling capacitor should be placed as close as possible to the supply pin.

The GND pin should be connected to the ground plane with a trace that is as short as possible. Controlled impedance traces of the shortest length possible should be used to connect to the signal I/O pins and should not pass over any voids in the ground plane. A 75 Ω impedance level is typically used in video applications. All signal outputs of the ADA4430-1 should include series termination resistors when driving transmission lines.

When the ADA4430-1 receives its inputs from a device with current outputs, the required load resistor value for the output current is most often different from the characteristic impedance of the signal traces. In this case, if the interconnections are sufficiently short (less than 2 inches), the trace does not have to be terminated in its characteristic impedance.

OUTLINE DIMENSIONS

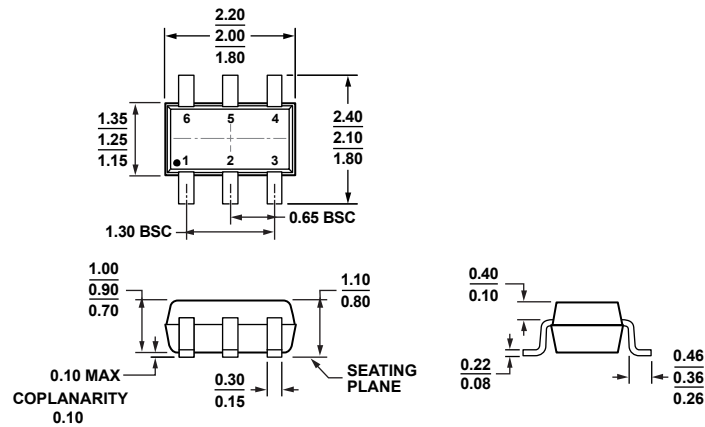

COMPLIANT TO JEDEC STANDARDS MO-203-AB

Figure 35. 6-Lead Thin Shrink Small Outline Transistor Package [SC70] (KS-6)
Dimensions shown in millimeters

072809-A

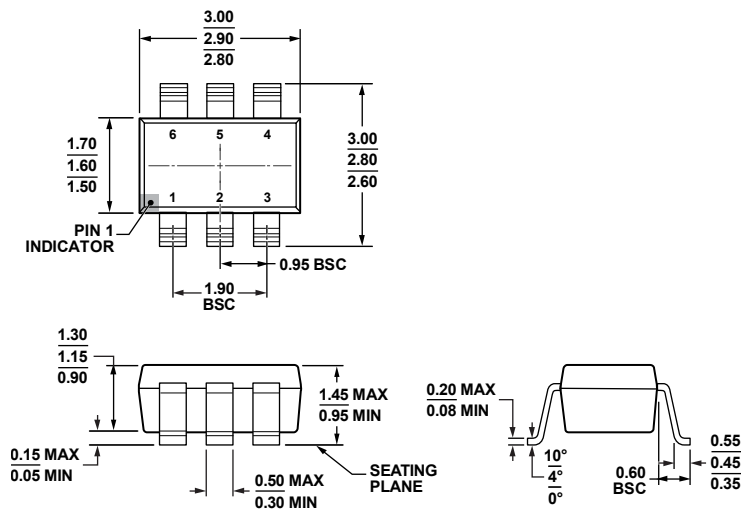

COMPLIANT TO JEDEC STANDARDS MO-178-AB

Figure 36. 6-Lead Small Outline Transistor Package [SOT-23] (RJ-6)
Dimensions shown in millimeters

121608-A

ADA4430-1

ORDERING GUIDE

Model ^{1, 2}	Temperature Range	Package Description	Package Option	Branding	Ordering Quantity
ADA4430-1YKSZ-R2	-40°C to +125°C	6-Lead SC70	KS-6	H0G	250
ADA4430-1YKSZ-R7	-40°C to +125°C	6-Lead SC70	KS-6	H0G	3,000
ADA4430-1YKSZ-RL	-40°C to +125°C	6-Lead SC70	KS-6	H0G	10,000
ADA4430-1WYRTZ-R7	-40°C to +125°C	6-Lead SOT-23	RJ-6	H25	3,000

¹ Z = RoHS-Compliant Part.

² W = Qualified for Automotive Applications.

AUTOMOTIVE PRODUCTS

The ADA4430-1W model is available with controlled manufacturing to support the quality and reliability requirements of automotive applications. Note that these automotive models may have specifications that differ from the commercial models; therefore, designers should review the Specifications section of this data sheet carefully. Only the automotive grade products shown are available for use in automotive applications. Contact your local Analog Devices account representative for specific product ordering information and to obtain the specific Automotive Reliability reports for these models.

NOTES

NOTES

Данный компонент на территории Российской Федерации

Вы можете приобрести в компании MosChip.

Для оперативного оформления запроса Вам необходимо перейти по данной ссылке:

<http://moschip.ru/get-element>

Вы можете разместить у нас заказ для любого Вашего проекта, будь то серийное производство или разработка единичного прибора.

В нашем ассортименте представлены ведущие мировые производители активных и пассивных электронных компонентов.

Нашей специализацией является поставка электронной компонентной базы двойного назначения, продукции таких производителей как XILINX, Intel (ex.ALTERA), Vicor, Microchip, Texas Instruments, Analog Devices, Mini-Circuits, Amphenol, Glenair.

Сотрудничество с глобальными дистрибьюторами электронных компонентов, предоставляет возможность заказывать и получать с международных складов практически любой перечень компонентов в оптимальные для Вас сроки.

На всех этапах разработки и производства наши партнеры могут получить квалифицированную поддержку опытных инженеров.

Система менеджмента качества компании отвечает требованиям в соответствии с ГОСТ Р ИСО 9001, ГОСТ РВ 0015-002 и ЭС РД 009

Офис по работе с юридическими лицами:

105318, г.Москва, ул.Щербаковская д.3, офис 1107, 1118, ДЦ «Щербаковский»

Телефон: +7 495 668-12-70 (многоканальный)

Факс: +7 495 668-12-70 (доб.304)

E-mail: info@moschip.ru

Skype отдела продаж:

moschip.ru

moschip.ru_4

moschip.ru_6

moschip.ru_9