



NXP remote keyless entry transponder combo IC NCF2960

Compact, single-chip solution for remote keyless entry

Delivering rugged performance in a very small (4 x 4 mm) footprint, this highly integrated solution maximizes design freedom and is ideal for advanced Combo-Key applications. Special features of the integrated RF transmitter support frequency hopping and ensure reliable operation even in RF-jammed environments.

Key features

- ▶ Single-chip security transponder and keyless entry solution
- ▶ 16-bit Harvard architecture
- ▶ On-chip UHF transmitter (315 / 434 / 868 / 915 MHz band)
- ▶ Transponder emulation based on HT3, HT-AES, or HT-Pro 2
- ▶ Calculation unit supporting HT3 (96-bit) and AES (128-bit)
- ▶ 16 KB user EROM for application
- ▶ 2 KB ultra-low-power EEPROM
- ▶ 1 KB RAM
- ▶ Up to eight command buttons with wake-up function
- ▶ I/O with current source for direct LED drive
- ▶ Stabilized RF output power
- ▶ Temperature sensor
- ▶ Single lithium cell operation (2.1 to 3.6 V)
- ▶ C-compiler supported software development
- ▶ HVQFN24 (4 x 4 mm) with wettable flanks

Applications

- ▶ Combo-Key applications that combine remote keyless entry with vehicle immobilization

The NXP NCF2960 is a second-generation Combo-key solution that combines a transponder, a microcontroller, and a radio transmitter in a tiny (4 x 4 mm) footprint.

The basic transponder operation is compatible with NXP's security transponder families, including HT3, HT-AES, and HT-Pro2. Custom transponder functions can be implemented using the ROM library of the device by the application.

The transponder circuitry is powered from the LF field and does not require a device battery supply. As a result, full operation is possible even when the battery is low.

The RISC controller uses NXP's third-generation Micro RISC Kernel (MRK III), a low-power implementation that features a 16-bit architecture and executes instructions in a single machine clock cycle.



The on-chip UHF transmitter requires only a single 27.6 MHz reference crystal and loop antenna matching circuitry to operate in one of the following bandwidths: 315 / 434 / 868 / 915 MHz bands. The RF multi-channel capability enables frequency hopping and ensures reliable operation in RF-jammed environments.

There are up to eight I/O ports, with one designed for use with a dedicated LED driver port, and up to eight inputs for command buttons. There is a temperature sensor for battery management and an on-chip pseudo-random number (PRN) generator for use with security protocols.

A fractional-N PLL allows compensation for initial XTAL tolerance. The device includes 2 KB of ultra-low-power serial EEPROM

memory (with access control defined by the application), 1 KB of RAM, and up to 16 KB of Flash-like EROM for the application code. The keyless entry code can be generated by the built-in, hardwired calculation unit or by a software-based algorithm.

The device is housed in a tiny 24-pin HVQFN package that consumes only 16 mm² of board space, so it enables ultra-compact designs with maximum freedom for key styling. Wettable package flanks allow optical soldering inspection without an x-ray.

The Flash-like EROM of the device supports in-circuitry programming and debugging of the application code.

NCF2960 application diagram

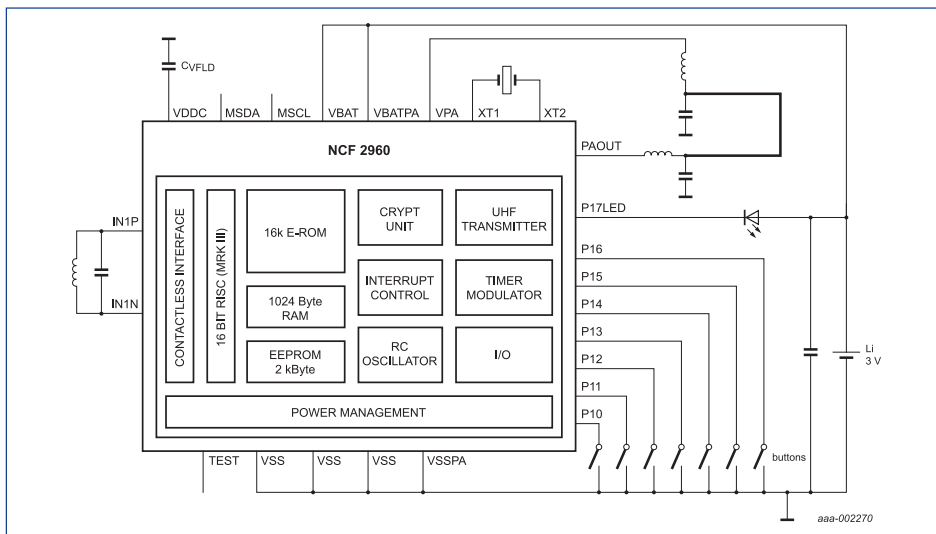

24-pin HVQFN package (4 x 4 mm)



NCF2960 demo board

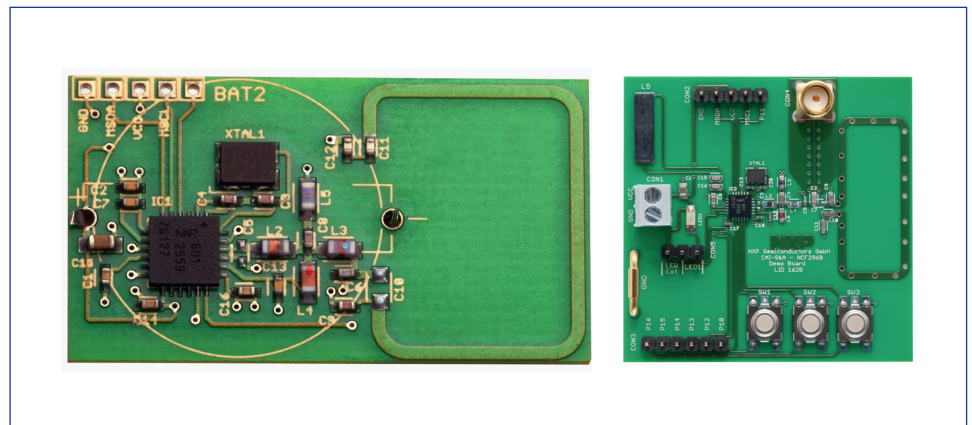

Данный компонент на территории Российской Федерации

Вы можете приобрести в компании MosChip.

Для оперативного оформления запроса Вам необходимо перейти по данной ссылке:

<http://moschip.ru/get-element>

Вы можете разместить у нас заказ для любого Вашего проекта, будь то серийное производство или разработка единичного прибора.

В нашем ассортименте представлены ведущие мировые производители активных и пассивных электронных компонентов.

Нашей специализацией является поставка электронной компонентной базы двойного назначения, продукции таких производителей как XILINX, Intel (ex.ALTERA), Vicor, Microchip, Texas Instruments, Analog Devices, Mini-Circuits, Amphenol, Glenair.

Сотрудничество с глобальными дистрибьюторами электронных компонентов, предоставляет возможность заказывать и получать с международных складов практически любой перечень компонентов в оптимальные для Вас сроки.

На всех этапах разработки и производства наши партнеры могут получить квалифицированную поддержку опытных инженеров.

Система менеджмента качества компании отвечает требованиям в соответствии с ГОСТ Р ИСО 9001, ГОСТ РВ 0015-002 и ЭС РД 009

Офис по работе с юридическими лицами:

105318, г.Москва, ул.Щербаковская д.3, офис 1107, 1118, ДЦ «Щербаковский»

Телефон: +7 495 668-12-70 (многоканальный)

Факс: +7 495 668-12-70 (доб.304)

E-mail: info@moschip.ru

Skype отдела продаж:

moschip.ru

moschip.ru_4

moschip.ru_6

moschip.ru_9