

Features

- High power capability
- $P_{OUT} = 350\text{ W min. with } 22\text{dB gain @ } 30\text{ MHz}$
- $P_{SAT} = 450\text{ W}$
- Low $R_{DS(on)}$
- STAC air cavity packaging technology - STAC[®] package
- Gold metallization
- Excellent thermal stability
- Common source configuration

Description

The STAC2943 is a gold metallized N-channel MOS field-effect RF power transistor, intended for use in 50 V dc large signal applications up to 150 MHz. This device offers a 20% higher power saturation than the SD2933, and is ideal for ISM applications where reliability and ruggedness are critical factors.

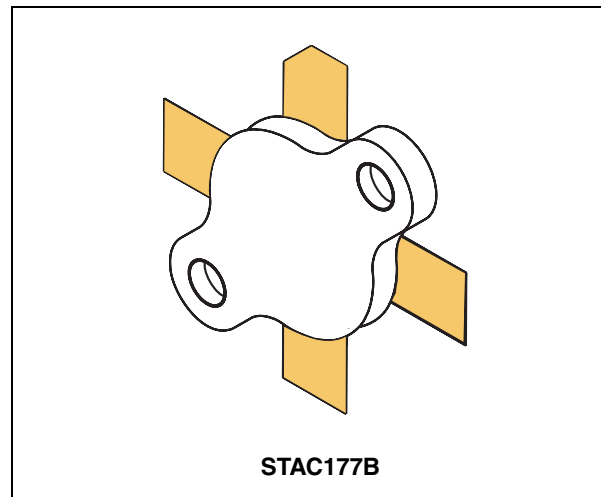

Figure 1. Pin connection

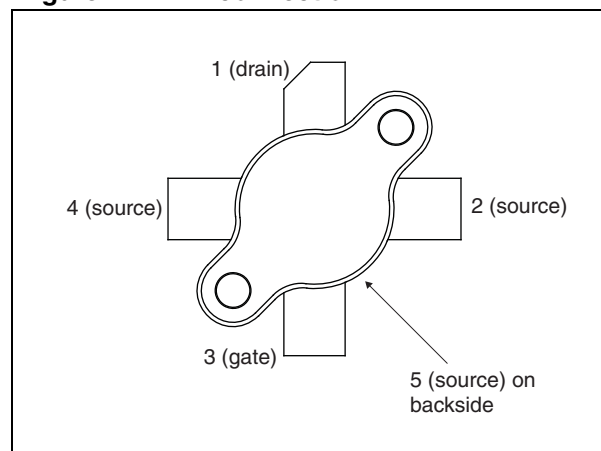

Table 1. Device summary

Order code	Marking	Base qty.	Package	Packaging ⁽¹⁾
STAC2943	STAC2943 ⁽¹⁾	25 pcs	STAC177B	Plastic tray

1. For more details please refer to [Chapter 6: Marking, packing and shipping specifications](#).

Contents

1	Electrical data	3
2	Electrical characteristics	4
3	Impedance	6
4	Typical performance	7
5	Package mechanical data	8
6	Marking, packing and shipping specifications	10
7	Revision history	11

1 Electrical data

($T_{CASE} = 25^{\circ}C$)

Table 2. Absolute maximum rating

Symbol	Parameter	Value	Unit
$V_{(BR)DSS}^{(1)}$	Drain source voltage	130	V
V_{DGR}	Drain-gate voltage ($R_{GS} = 1M\Omega$)	130	V
V_{GS}	Gate-source voltage	± 20	V
I_D	Drain current	40	A
P_{DISS}	Power dissipation	795	W
T_j	Max. operating junction temperature	200	$^{\circ}C$
E_{AS}	Avalanche energy, single pulse ($I_D = 53A$, $800\mu H$ coil)	1100	mJ
T_{STG}	Storage temperature	-65 to +150	$^{\circ}C$

1. $T_j = 150^{\circ}C$

Table 3. Thermal data

Symbol	Parameter	Value	Unit
R_{thJC}	Junction to case thermal resistance	0.22	$^{\circ}C/W$

2 Electrical characteristics

($T_{CASE} = 25^{\circ}C$)

Table 4. Static

Symbol	Test conditions		Min.	Typ.	Max.	Unit
$V_{(BR)DSS}^{(1)}$	$V_{GS} = 0\text{ V}$	$I_{DS} = 200\text{ mA}$	130			V
I_{DSS}	$V_{GS} = 0\text{ V}$	$V_{DS} = 50\text{ V}$			200	μA
I_{GSS}	$V_{GS} = 20\text{ V}$	$V_{DS} = 0\text{ V}$			500	nA
$V_{GS(Q)}^{(2)}$	$V_{DS} = 10\text{ V}$	$I_D = 250\text{ mA}$			see table below	V
$V_{DS(ON)}$	$V_{GS} = 10\text{ V}$	$I_D = 20\text{ A}$			2	V
$G_{FS}^{(2)}$	$V_{DS} = 10\text{ V}$	$I_D = 10\text{ A}$	see table below			mho
C_{ISS}	$V_{GS} = 0\text{ V}$	$V_{DS} = 50\text{ V}$		830		pF
C_{OSS}	$V_{GS} = 0\text{ V}$	$V_{DS} = 50\text{ V}$		470		pF
C_{RSS}	$V_{GS} = 0\text{ V}$	$V_{DS} = 50\text{ V}$		35		pF

- $T_J = 150^{\circ}C$
- V_{GS} and G_{FS} sorts for each unit see [Table 6](#) and [Table 7](#).

Table 5. Dynamic

Symbol	Test conditions		Min.	Typ.	Max.	Unit
P_{OUT}	$V_{DD} = 50\text{ V}$	$I_{DQ} = 250\text{ mA}$ $f = 30\text{ MHz}$	350	450		W
G_{PS}	$V_{DD} = 50\text{ V}$	$I_{DQ} = 250\text{ mA}$ $P_{OUT} = 350\text{ W}$ $f = 30\text{ MHz}$	22	25		dB
h_D	$V_{DD} = 50\text{ V}$	$I_{DQ} = 250\text{ mA}$ $P_{OUT} = 350\text{ W}$ $f = 30\text{ MHz}$	60	65		%
Load Mismatch	$V_{DD} = 50\text{ V}$	$I_{DQ} = 250\text{ mA}$ $P_{OUT} = 350\text{ W}$ $f = 30\text{ MHz}$ All phase angles	3:1			VSWR

Table 6. G_{FS} sorts

Symbol	Value
A	10 - 10.99
B	11 - 11.99
C	12 - 12.99
D	13 - 13.99
E	14 - 14.99
F	15 - 15.99

Table 6. G_{FS} sorts (continued)

Symbol	Value
G	16 - 16.99
H	17 - 18

Table 7. V_{GS} sort

V_{GS} sort	Value
1	1.5 - 2.0
2	2.0 - 2.5
3	2.5 - 3.0
4	3.0 - 3.5
5	3.5 - 4.0

3 Impedance

Figure 2. Impedance Data Schematic

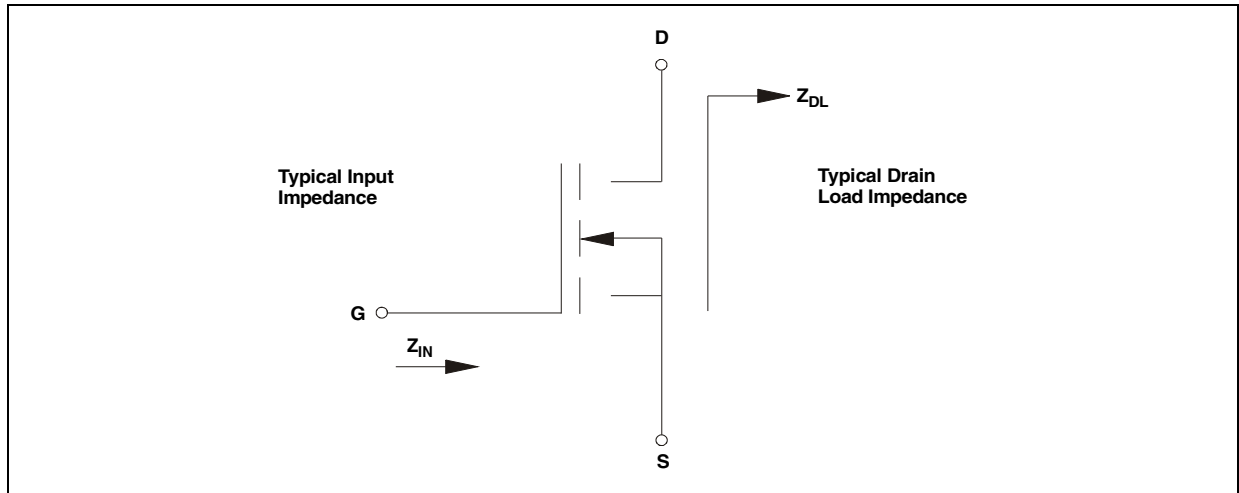

Table 8. Impedance data

f	Z_{IN} (Ω)	Z_{DL} (Ω)
30 MHz	$1.3 - j 2.9$	$3.1 + j 2.3$
108 MHz	$1.4 - j 2.4$	$1.9 + j 1.4$
175 MHz	$1.4 - j 2.2$	$1.7 + j 1.6$

4 Typical performance

Figure 3. Capacitance vs drain voltage

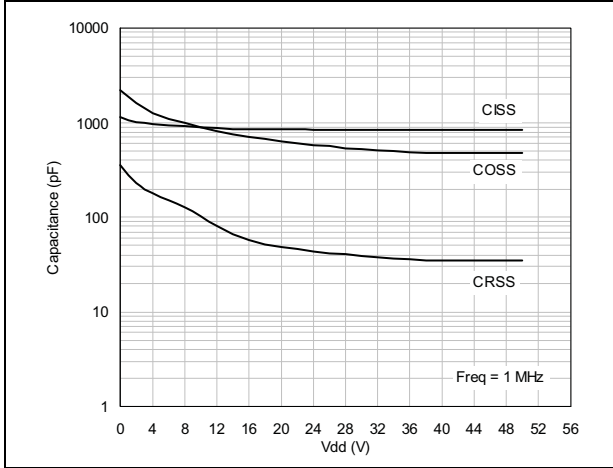

Figure 4. Drain current vs gate voltage

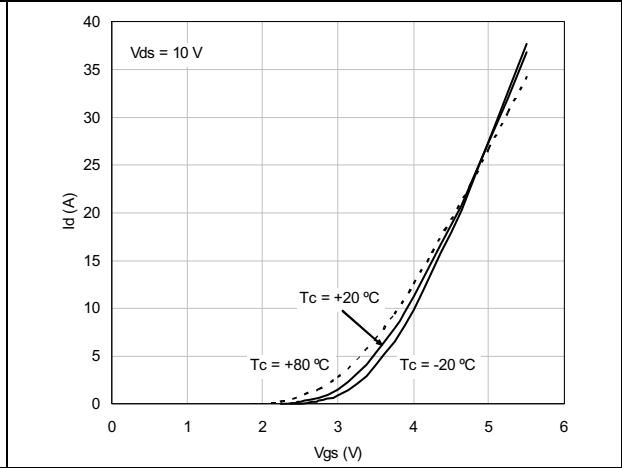
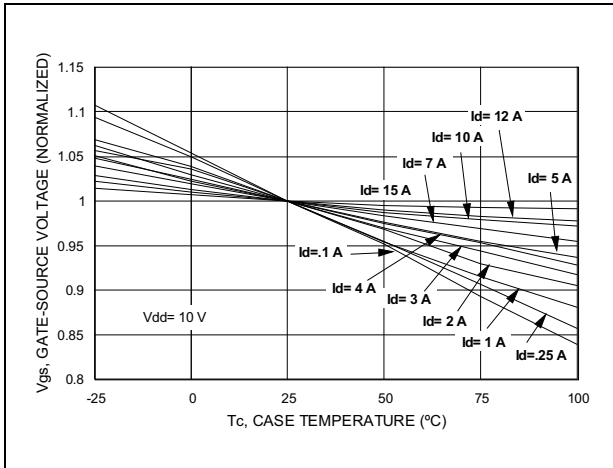

Figure 5. Gate-source voltage vs case temperature



5 Package mechanical data

In order to meet environmental requirements, ST offers these devices in different grades of ECOPACK® packages, depending on their level of environmental compliance. ECOPACK® specifications, grade definitions and product status are available at: www.st.com. ECOPACK is an ST trademark.

Table 9. STAC177B mechanical data

Dim	mm			inch		
	Min.	Typ.	Max.	Min.	Typ.	Max.
A	5.72		5.97	0.225		0.235
B	6.73		6.99	0.265		0.275
C	21.84		22.10	0.860		0.870
D	28.70		28.96	1.130		1.140
E		28.02			1.103	
F	0.10		0.15	0.004		0.006
G		0.81			0.032	
H	1.45		1.70	0.057		0.067
I	5.79		6.15	0.228		0.242
J	27.43		28.45	1.080		1.120
K	15.01		15.27	0.591		0.601

Figure 6. STAC177B mechanical drawing

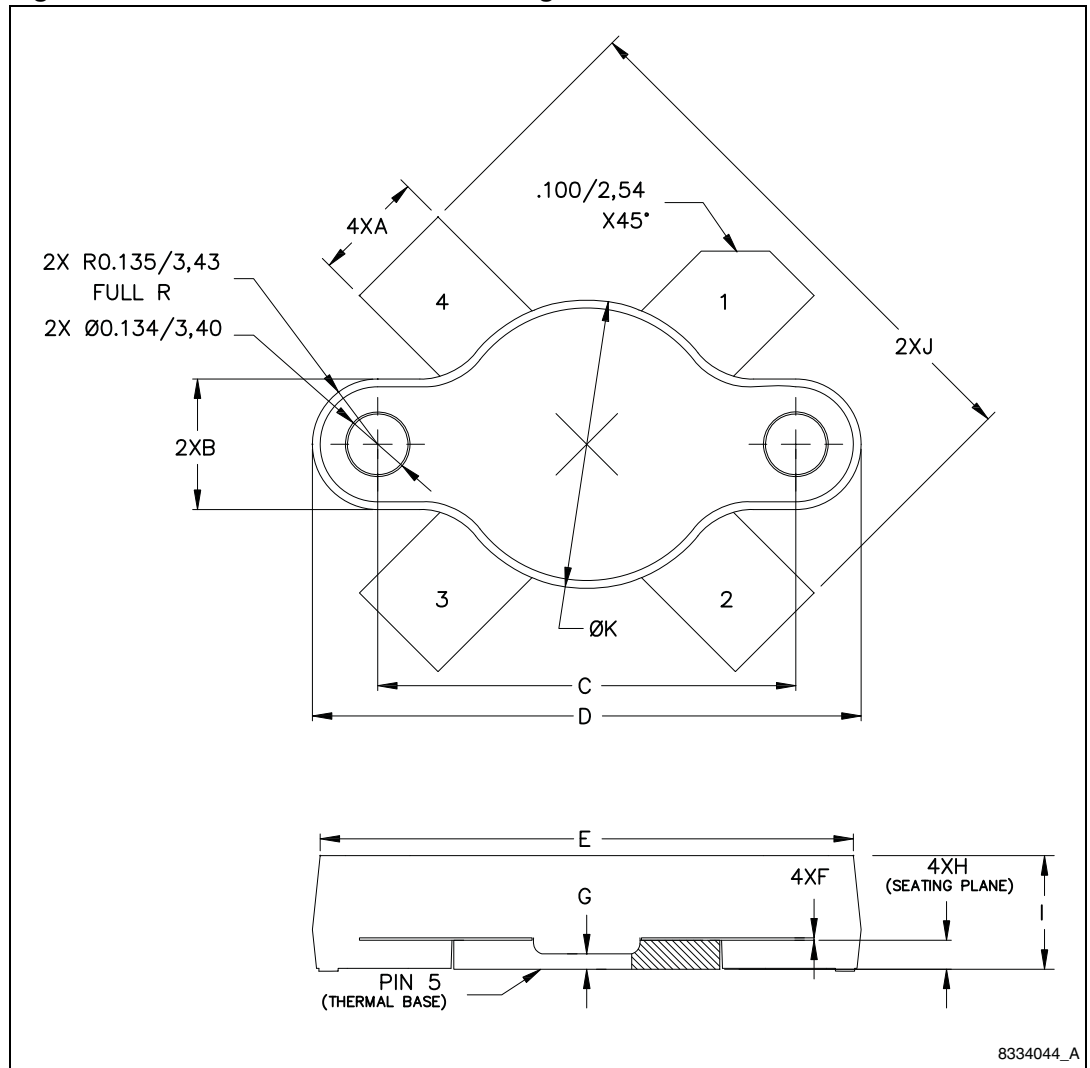

6 Marking, packing and shipping specifications

Table 10. Packing and shipping specifications

Order code	Packaging	Pcs per tray	Dry pack humidity	VGS and GFS code	Lot code
STAC2943	Plastic tray	25	< 10 %	Not mixed	Not mixed

Figure 7. Marking layout

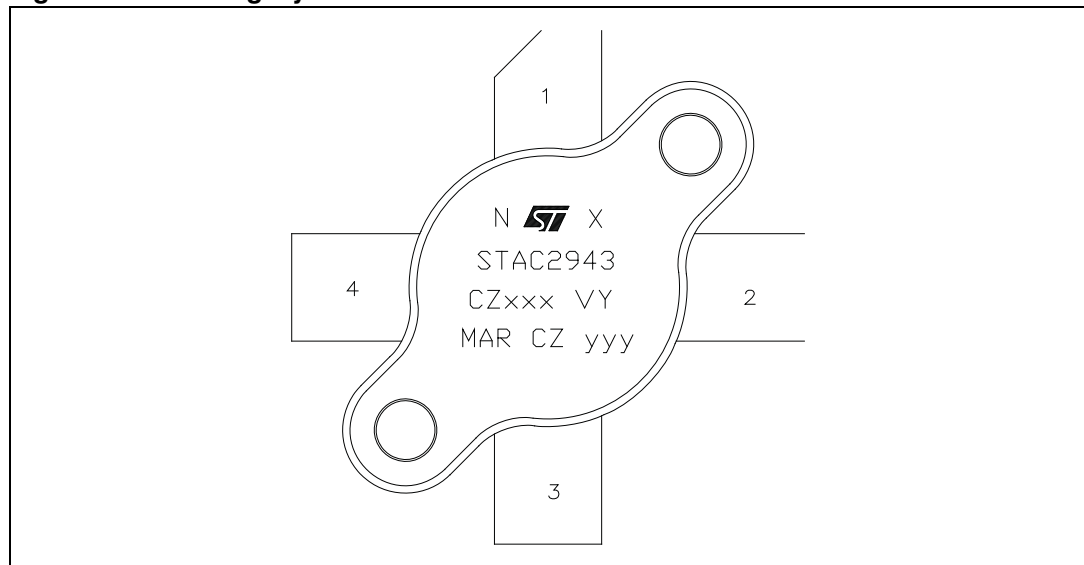

Table 11. Marking specifications

Symbol	Description
N	V _{GS} sort
X	G _{FS} sort
CZ	Assembly plant
xxx	Last 3 digit of diffusion lot
VY	Diffusion plant
MAR	Country of origin
CZ	Test and finishing plant
y	Assembly year
yy	Assembly week

7 Revision history

Table 12. Document revision history

Date	Revision	Description of Changes
16-Jan-2012	1	First Issue.

Please Read Carefully:

Information in this document is provided solely in connection with ST products. STMicroelectronics NV and its subsidiaries ("ST") reserve the right to make changes, corrections, modifications or improvements, to this document, and the products and services described herein at any time, without notice.

All ST products are sold pursuant to ST's terms and conditions of sale.

Purchasers are solely responsible for the choice, selection and use of the ST products and services described herein, and ST assumes no liability whatsoever relating to the choice, selection or use of the ST products and services described herein.

No license, express or implied, by estoppel or otherwise, to any intellectual property rights is granted under this document. If any part of this document refers to any third party products or services it shall not be deemed a license grant by ST for the use of such third party products or services, or any intellectual property contained therein or considered as a warranty covering the use in any manner whatsoever of such third party products or services or any intellectual property contained therein.

UNLESS OTHERWISE SET FORTH IN ST'S TERMS AND CONDITIONS OF SALE ST DISCLAIMS ANY EXPRESS OR IMPLIED WARRANTY WITH RESPECT TO THE USE AND/OR SALE OF ST PRODUCTS INCLUDING WITHOUT LIMITATION IMPLIED WARRANTIES OF MERCHANTABILITY, FITNESS FOR A PARTICULAR PURPOSE (AND THEIR EQUIVALENTS UNDER THE LAWS OF ANY JURISDICTION), OR INFRINGEMENT OF ANY PATENT, COPYRIGHT OR OTHER INTELLECTUAL PROPERTY RIGHT.

UNLESS EXPRESSLY APPROVED IN WRITING BY TWO AUTHORIZED ST REPRESENTATIVES, ST PRODUCTS ARE NOT RECOMMENDED, AUTHORIZED OR WARRANTED FOR USE IN MILITARY, AIR CRAFT, SPACE, LIFE SAVING, OR LIFE SUSTAINING APPLICATIONS, NOR IN PRODUCTS OR SYSTEMS WHERE FAILURE OR MALFUNCTION MAY RESULT IN PERSONAL INJURY, DEATH, OR SEVERE PROPERTY OR ENVIRONMENTAL DAMAGE. ST PRODUCTS WHICH ARE NOT SPECIFIED AS "AUTOMOTIVE GRADE" MAY ONLY BE USED IN AUTOMOTIVE APPLICATIONS AT USER'S OWN RISK.

Resale of ST products with provisions different from the statements and/or technical features set forth in this document shall immediately void any warranty granted by ST for the ST product or service described herein and shall not create or extend in any manner whatsoever, any liability of ST.

ST and the ST logo are trademarks or registered trademarks of ST in various countries.

Information in this document supersedes and replaces all information previously supplied.

The ST logo is a registered trademark of STMicroelectronics. All other names are the property of their respective owners.

© 2012 STMicroelectronics - All rights reserved

STMicroelectronics group of companies

Australia - Belgium - Brazil - Canada - China - Czech Republic - Finland - France - Germany - Hong Kong - India - Israel - Italy - Japan - Malaysia - Malta - Morocco - Philippines - Singapore - Spain - Sweden - Switzerland - United Kingdom - United States of America

www.st.com

Данный компонент на территории Российской Федерации

Вы можете приобрести в компании MosChip.

Для оперативного оформления запроса Вам необходимо перейти по данной ссылке:

<http://moschip.ru/get-element>

Вы можете разместить у нас заказ для любого Вашего проекта, будь то серийное производство или разработка единичного прибора.

В нашем ассортименте представлены ведущие мировые производители активных и пассивных электронных компонентов.

Нашей специализацией является поставка электронной компонентной базы двойного назначения, продукции таких производителей как XILINX, Intel (ex.ALTERA), Vicor, Microchip, Texas Instruments, Analog Devices, Mini-Circuits, Amphenol, Glenair.

Сотрудничество с глобальными дистрибьюторами электронных компонентов, предоставляет возможность заказывать и получать с международных складов практически любой перечень компонентов в оптимальные для Вас сроки.

На всех этапах разработки и производства наши партнеры могут получить квалифицированную поддержку опытных инженеров.

Система менеджмента качества компании отвечает требованиям в соответствии с ГОСТ Р ИСО 9001, ГОСТ РВ 0015-002 и ЭС РД 009

Офис по работе с юридическими лицами:

105318, г.Москва, ул.Щербаковская д.3, офис 1107, 1118, ДЦ «Щербаковский»

Телефон: +7 495 668-12-70 (многоканальный)

Факс: +7 495 668-12-70 (доб.304)

E-mail: info@moschip.ru

Skype отдела продаж:

moschip.ru

moschip.ru_4

moschip.ru_6

moschip.ru_9