

## WiFi3 click™

### 1. Introduction

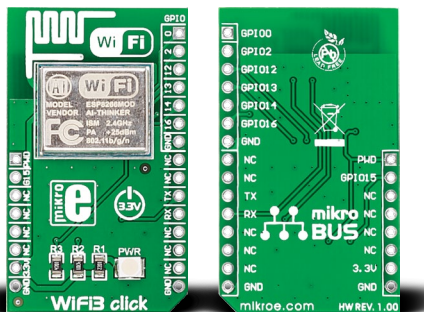

**WiFi3 click™** is a complete self-contained WiFi solution carrying the **ESP8266MOD** module with a system on chip. The module has an integrated TCP/IP stack, supports Wi-Fi Direct (p2p) and boasts powerful processing and storage capabilities. Alongside a standard **mikroBUS™** socket, with WiFi3 click™ you'll have additional **6 GPIO pins at your disposal**. WiFi3 click™ communicates with the target board microcontroller through mikroBUS™ RX, TX, AN (PWD) and RST (G15) lines. The board uses a 3.3V power supply only.

### 2. Soldering the headers

Before using your click™ board, make sure to solder 1x8 male headers to both left and right side of the board. Two 1x8 male headers are included with the board in the package.

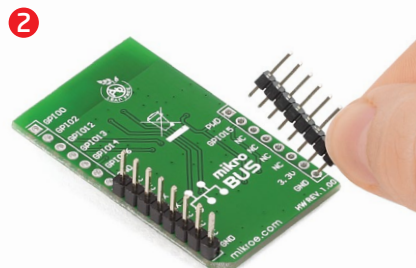
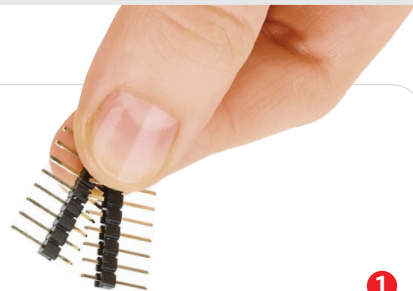

Turn the board upside down so that the bottom side is facing you upwards. Place shorter pins of the header into the appropriate soldering pads.

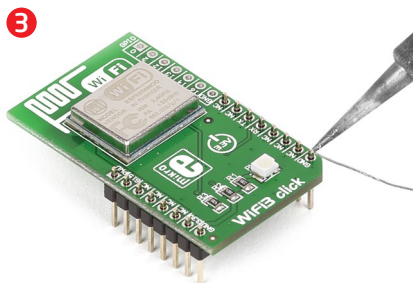

Turn the board upward again. Make sure to align the headers so that they are perpendicular to the board, then solder the pins carefully.

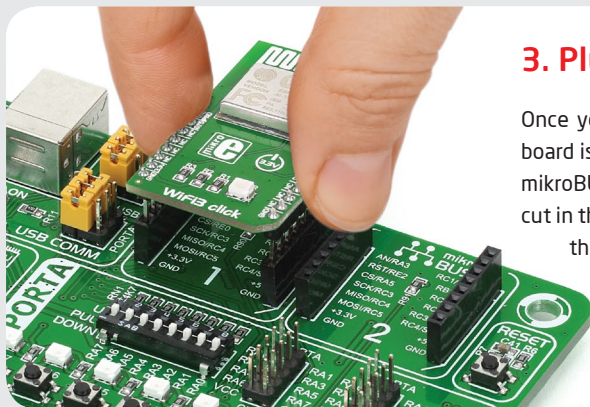

### 3. Plugging the board in

Once you have soldered the headers your board is ready to be placed into the desired mikroBUS™ socket. Make sure to align the cut in the lower-right part of the board with the markings on the silkscreen at the mikroBUS™ socket. If all the pins are aligned correctly, push the board all the way into the socket.

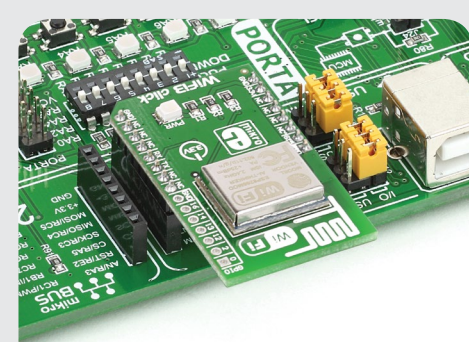

### 4. Essential features

WiFi3 click™ is ideally suited for **IoT applications**. The **System on Chip offloads all the networking functions from the MCU**. You can integrate it with sensors and actuators through its GPIOs and connect your things to the internet with minimum development effort. In place of standard mikroBUS™ AN and RST pins, WiFi3 click™ has PWD and G15 pins. These correspond to CH\_PD and GPIO15 pins on the module. When you connect WiFi3 click™ to the mikroBUS™ socket, set the PWD pin to VCC and the G15 pin to GND, from within your code.

**click™**  
**BOARD**  
[www.mikroe.com](http://www.mikroe.com)

WiFi3 click™ manual  
ver. 1.00



0100000070468

## 5. WiFi3 click™ board schematic

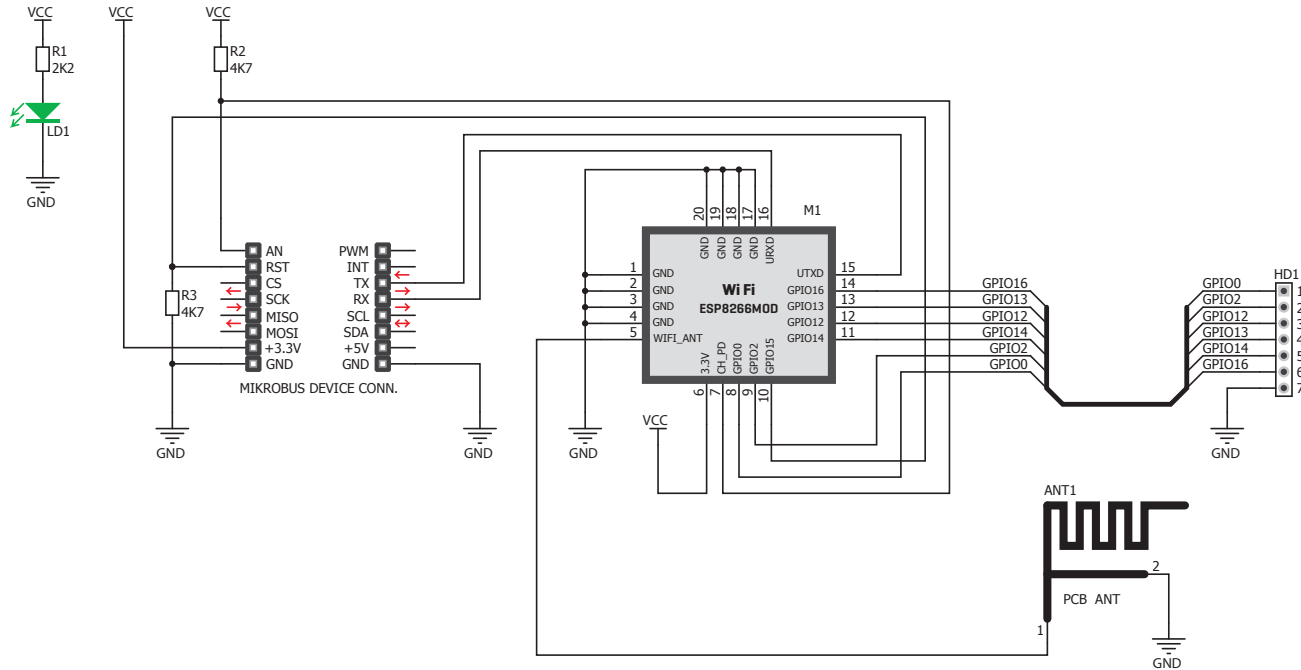

## 6. PCB antenna



WiFi3 click™ features a PCB trace antenna, designed for the 2400-2483.5 MHz frequency band.

## 7. Code examples

Once you have done all the necessary preparations, it's time to get your click™ board up and running. We have provided examples for mikroC™, mikroBasic™ and mikroPascal™ compilers on our **Libstock** website. Just download them and you are ready to start.



## 8. Support

MikroElektronika offers **free tech support** ([www.mikroe.com/support](http://www.mikroe.com/support)) until the end of the product's lifetime, so if something goes wrong, we're ready and willing to help!

## Данный компонент на территории Российской Федерации

### Вы можете приобрести в компании MosChip.

Для оперативного оформления запроса Вам необходимо перейти по данной ссылке:

<http://moschip.ru/get-element>

Вы можете разместить у нас заказ для любого Вашего проекта, будь то серийное производство или разработка единичного прибора.

В нашем ассортименте представлены ведущие мировые производители активных и пассивных электронных компонентов.

Нашей специализацией является поставка электронной компонентной базы двойного назначения, продукции таких производителей как XILINX, Intel (ex.ALTERA), Vicor, Microchip, Texas Instruments, Analog Devices, Mini-Circuits, Amphenol, Glenair.

Сотрудничество с глобальными дистрибьюторами электронных компонентов, предоставляет возможность заказывать и получать с международных складов практически любой перечень компонентов в оптимальные для Вас сроки.

На всех этапах разработки и производства наши партнеры могут получить квалифицированную поддержку опытных инженеров.

Система менеджмента качества компании отвечает требованиям в соответствии с ГОСТ Р ИСО 9001, ГОСТ РВ 0015-002 и ЭС РД 009

### Офис по работе с юридическими лицами:

105318, г.Москва, ул.Щербаковская д.3, офис 1107, 1118, ДЦ «Щербаковский»

Телефон: +7 495 668-12-70 (многоканальный)

Факс: +7 495 668-12-70 (доб.304)

E-mail: [info@moschip.ru](mailto:info@moschip.ru)

Skype отдела продаж:

moschip.ru

moschip.ru\_4

moschip.ru\_6

moschip.ru\_9