

9000 series

Inductive sensing joysticks

Distinctive features and specifications



- One or two axis
- Signal mixing options
- 5 - 15V operation
- Dual redundant outputs.
- Infinite resolution
- Inductive sensing
- Consistent performance
- IP65 above panel
- Long service life
- Wide range of handles
- Optional “at center” and “internal fault” detection

CABLE

- 14/0.12 – Fourteen strands of 0.12mm diameter tinned annealed copper wire PVC insulated, to a nominal OD of 1mm
- Red – +VCC
 - Blue – X axis wiper
 - Green – Center tap Reference
 - Orange – Center Detect or Combined Fault & Center Detect
 - Black – 0V for X and Y axis
 - Yellow – Y axis wiper
 - White – Fault detect
 - Gray – Mirror of Y axis wiper
 - Brown – Mirror of X axis wiper
- 7/0.127 – Seven strands of 0.127mm diameter tinned copper wire ETFE insulated, to a nominal OD of 0.7mm
- Orange – Pushbutton

- NOTES:
1. All 9000 series are supplied with 150mm of twisted cable harness, with tinned ends.
 2. Connectors fitted upon request.

TECHNICAL

- Life Cycles: > 10 Million Operations
- Signal Swing: $\pm 10\%$ of VCC to $\pm 50\%$ of VCC
- Output at Center: $\pm 1\%$
- Signal Ripple: <1% of Output
- ESD Immunity: >12KV – Correctly Installed
- RFI Rejection: >40V/m – Correctly Installed
- Body Material: Glass Reinforced ABS
- Shaft Diameter: 5mm
- Gimbal Pivot: Acetal & Hardened Steel
- Weight: 90 Grams (0.20lb)
- Temperature Range: -20°C to +55°C (-4°F to +131°F)
- Supply Voltage: 4.75V Min to 15V Max
- Output Signal Tolerance: $\pm 10\%$ of Output
- Output Impedance: 1.8k $\pm 1\%$
- Supply Current: Typically 10mA
- RFI Rejection: >20V/m – Bare Joystick
- Preferred Load: >10K
- Shaft Material: Stainless Steel
- Other Materials: Brass, Acetal, Nylon
- Boot: Neoprene
- Above Panel Seal: IP65
- Operating Lever Deflection: $\pm 18\%$

NOTES:

1. All values are nominal.
2. All specifications shown are based on a standard configuration and are provided for guidance only.
3. Please refer to APEM for assistance on how to achieve the best performance from your chosen configuration.

9000 series

Inductive sensing joysticks

Overview

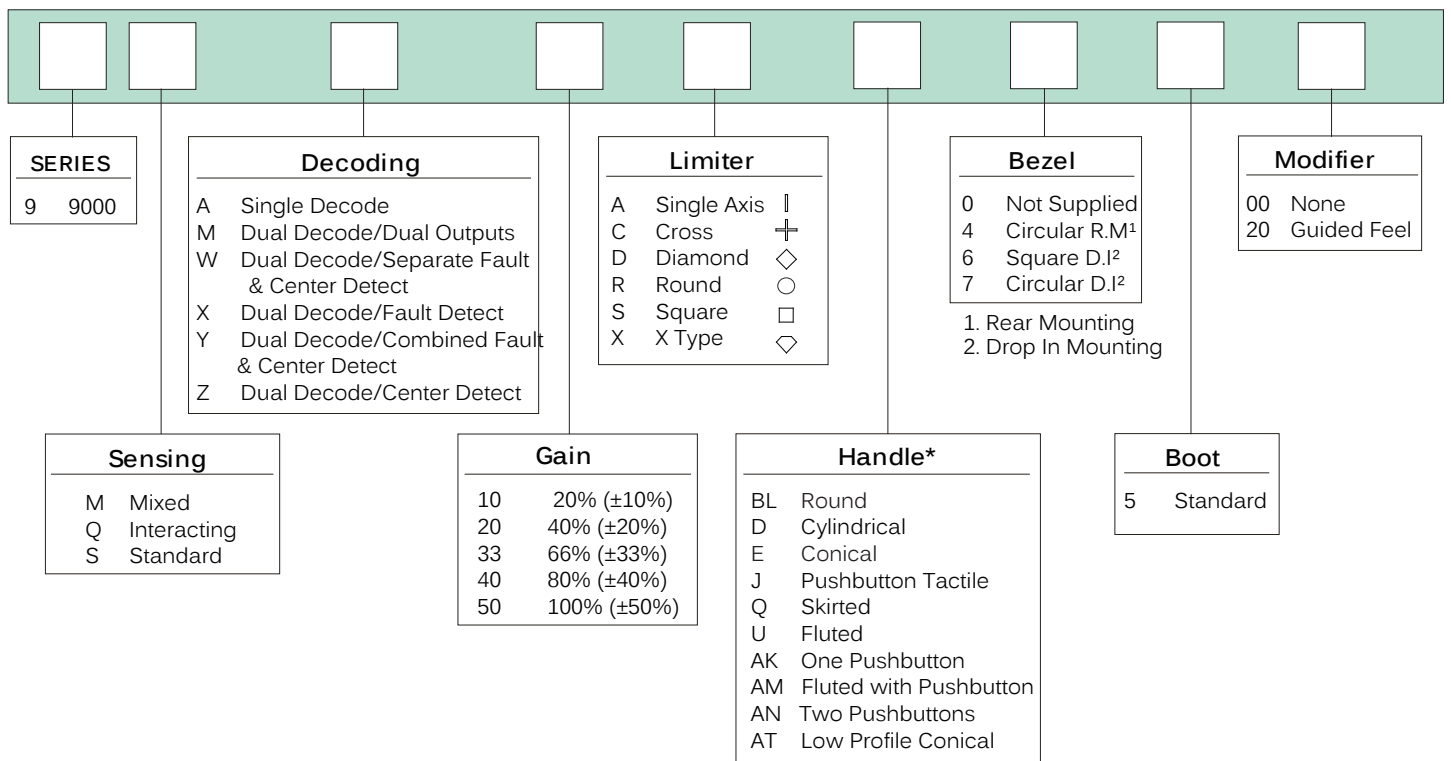

* for more handles see next pages

NOTES:

1. BEZEL OPTIONS

For drop in mounting, please specify bezel option 6 or 7. For sub-panel mounting, no bezel is necessary, unless the boot is required to seal to the front face of the panel in which case bezel option 4 should be specified. Bezels 6 & 7 clamp the boot and top face of the joystick body to the panel whereas bezel 4 clamps only the boot.

Some handles may be larger than some panel cut-outs. This may restrict the choice of mounting and bezel options. Please refer to APEM for assistance.

2. SPRINGS

As standard 9000 series are offered sprung to center. The standard spring force requires 1.3N (nominally) to off-center the joystick. The 9000 series may be specified with a lighter spring (1N), or a stronger spring (1.6N)

Note: Forces quoted are subject to exact joystick configuration and are provided as a guide only.

3. DUAL DECODE INTERFACE

For optimum performance of the center detect and fault detect signals, Apem recommends the signals are "pulled high" via an input resistor of typically 22K, on the controller circuitry.

4. CENTER TAP REFERENCE

All 9000 series output a center tap reference as standard. This reference is set within the joystick at 50% of VCC (±1%).

For optimum accuracy the outputs should be read relative to the center tap.

5. NON STANDARD

Further non standard options including custom handles or special limiters are available. Please refer to the factory for further details.

NEAR EQUIVALENT CIRCUIT

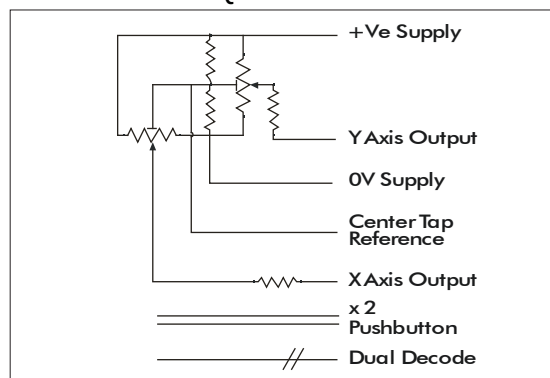

Note: The company reserves the right to change specifications without notice.

9000 series

Inductive sensing joysticks

Overview

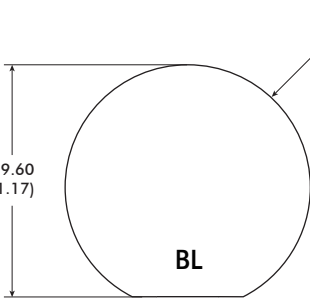
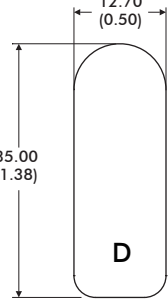
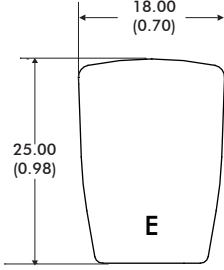
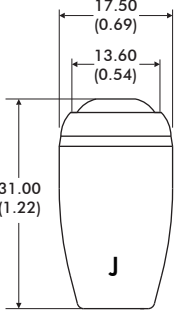
 <p>BL</p>	 <p>D</p>	 <p>E</p>	 <p>J</p>
<p>MATERIAL: Nylon FINISH: Non Textured STANDARD COLOR: Black OTHER COLORS: Not Available NOTES:</p>	<p>MATERIAL: Aluminum FINISH: Anodized STANDARD COLOR: Black OTHER COLORS: Not Available NOTES:</p>	<p>MATERIAL: Nylon FINISH: Sparked Matt STANDARD COLOR: Black OTHER COLORS: Upon Request NOTES:</p>	<p>MATERIAL: ABS FINISH: Sparked Matt STANDARD COLOR: Black OTHER COLORS: Upon Request NOTES: Uses APEM IS Switches</p>

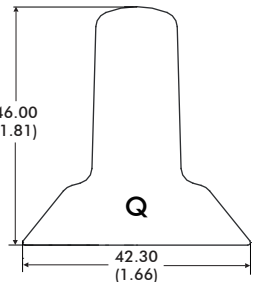
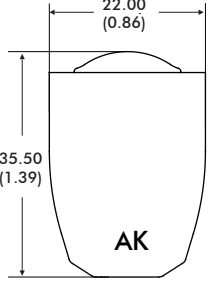
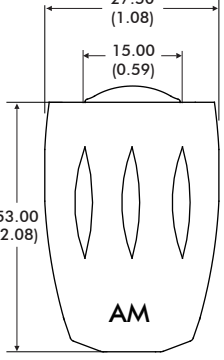
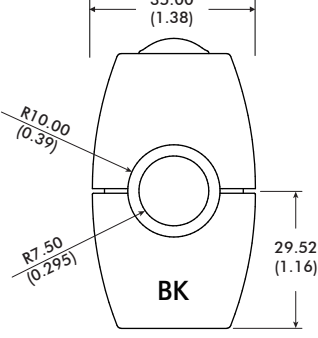
 <p>Q</p>	 <p>AK</p>	 <p>AM</p>	 <p>BK</p>
<p>MATERIAL: Nylon FINISH: Sparked Matt STANDARD COLOR: Black OTHER COLORS: Upon Request NOTES:</p>	<p>MATERIAL: Aluminum FINISH: Anodized STANDARD COLOR: Black OTHER COLORS: Not Available NOTES: Uses APEM IA Switches</p>	<p>MATERIAL: Aluminum FINISH: Anodized STANDARD COLOR: Black OTHER COLORS: Upon Request NOTES: Uses APEM IA Switches</p>	<p>MATERIAL: ABS FINISH: Sparked Matt STANDARD COLOR: Black OTHER COLORS: Upon Request NOTES: Uses APEM IA Switches</p>

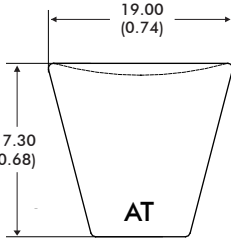
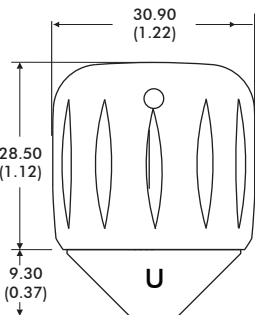
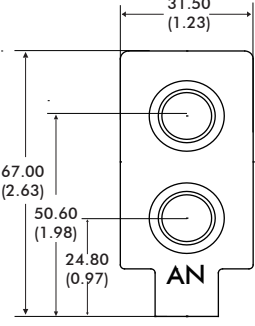
 <p>AT</p>	 <p>U</p>	 <p>AN</p>
<p>MATERIAL: Nylon FINISH: Sparked Matt STANDARD COLOR: Black OTHER COLORS: Upon Request NOTES:</p>	<p>MATERIAL: Aluminum FINISH: Anodized STANDARD COLOR: Black OTHER COLORS: Not Available NOTES:</p>	<p>MATERIAL: Delrin FINISH: Gloss STANDARD COLOR: Black OTHER COLORS: Not Available NOTES: Uses APEM IS Switches</p>

NOTES:

1. Dimensions are in mm/(inch).
2. Unless otherwise specified, all joysticks are supplied with black switches in the handles.

Note: The company reserves the right to change specifications without notice.

9000 series

Inductive sensing joysticks

Overview

GENERAL DIMENSIONS

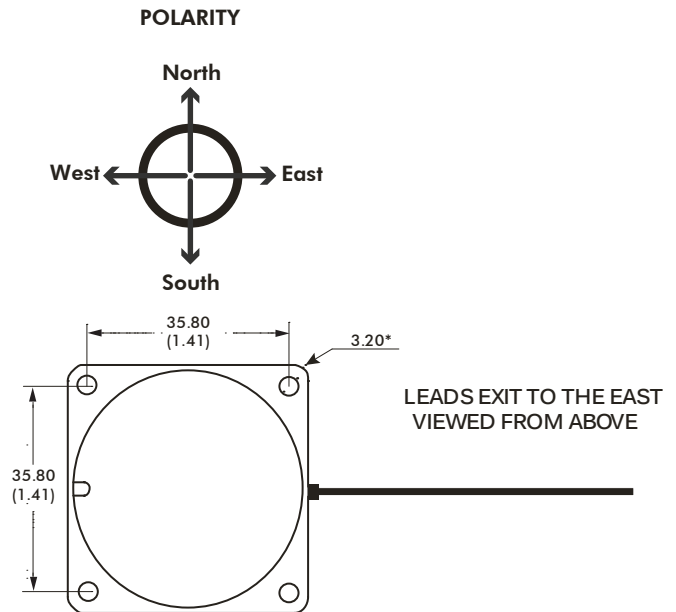
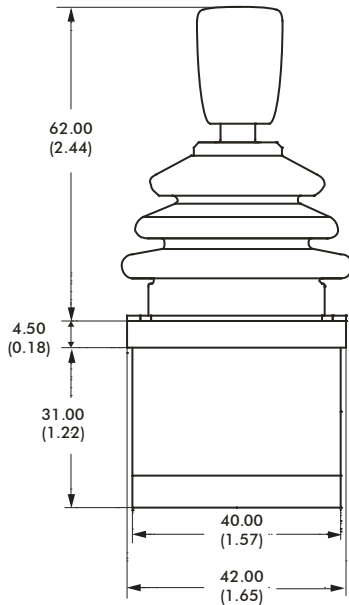

DROP IN MOUNTING - PANEL CUT-OUT & MOUNTING INSTALLATION

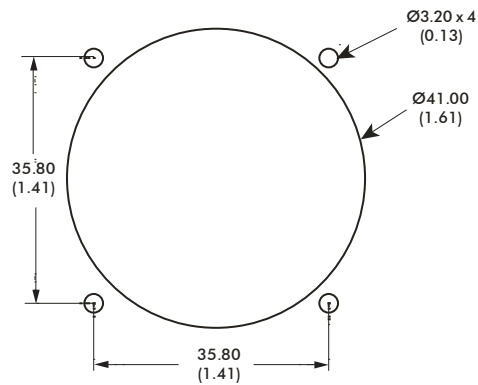

The joystick is dropped into the panel cut-out. The joystick and boot must be kept in place by bezel (option 6 & 7). For panel thickness of <3mm, M3 x 16 countersunk machine screws are recommended. To ensure a good panel seal, gaskets are available as an optional extra.

NOTES:

1. Dimensions are in mm/(inch).
2. The dimensions shown are for a generic 9000 series with the conical E type handle. For specific dimensions of this or any other configuration please refer to APEM.

Note: The company reserves the right to change specifications without notice.

9000 series

Inductive sensing joysticks

Overview

MOUNTING OPTION A - PANEL CUT-OUT & MOUNTING INSTALLATION

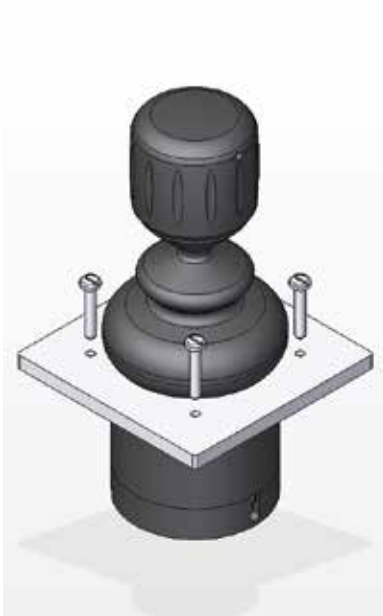

MOUNTING CUT-OUT

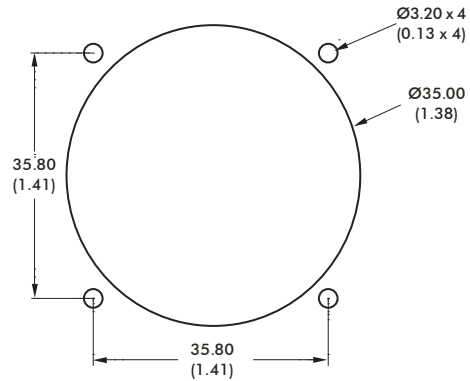

When mounted this way the panel acts as the bezel and no separate bezel is needed. M3 machine screws are recommended.

MOUNTING OPTION B - PANEL CUT-OUT & MOUNTING INSTALLATION

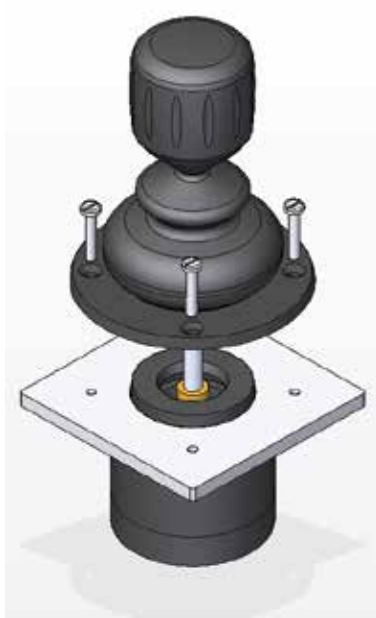

MOUNTING CUT-OUT

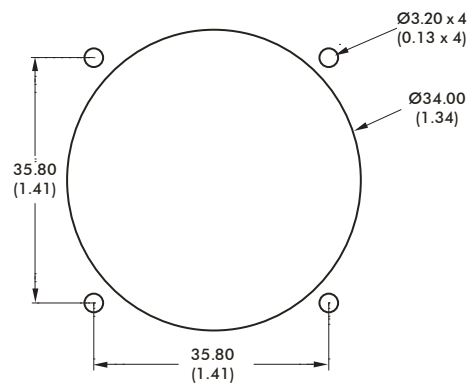

The joystick flange is mounted beneath the panel and the base of the boot must be brought through the panel cut-out and held in place with the circular bezel (option 4). For panel thicknesses of 3mm, M3 x 16 countersunk machine screws are recommended.

NOTES:

1. Dimensions are in mm/(inch).
2. When sub panel mounting, great care should be taken not to damage the boot, or any of the mechanism under the boot. All panel cut-outs should be free from sharp edges and swarf that may damage the boot.
3. Some handles are larger than the recommended panel cut-out. In this case drop-in mounting must be specified.

9000 series

Inductive sensing joysticks

Overview

CIRCUITRY

The 9000 series joystick operates by passing an oscillating current through a drive coil, directly mounted at the lower end of the operating lever, and immediately above the four sensing coils. When the shaft and drive coil moves away from the center, the signals detected in each opposing pair of coils increase nominally in proportion to deflection. The phase of those signals determine the direction. Synchronous electronic switches followed by integrating amplifiers provide DC signals directly equivalent to those of potentiometer joysticks, but with fixed output impedance and free of wiper noise and track wear.

DUAL DECODE

Designed for use in the most safety-critical applications, the 9000 series incorporates comprehensive internal monitoring circuitry whereby output signals are continually compared with separately generated 'mirror signals'. In the unlikely event of an internal fault, the dual decode system will generate a separate fault signal, enabling the controller to fail-to-safe. The dual decode system is a complete internal self-monitoring system, providing a far higher standard of protection. An additional, 'away from center' signal is also available whenever required. Although the monitoring of the joystick is fully internal, the inverse 'mirror signals' can be available as external outputs where the monitor function is incorporated within the controller circuitry.

GUIDED FEEL

The 9000 series may also be specified with guided feel. A joystick with guided feel moves more readily towards the poles (N, S, E and W) and while it can still move away from the poles, the force required to do so is greater. Unless specified otherwise, joysticks are supplied as standard without guiding. This standard configuration allows the user to move the joystick anywhere within the limiter with the same force and without any bias.

FUNCTIONAL OPTIONS

The 9000 series can be configured in three different modes:

- Orthogonal, standard signals - Replicating that of a potentiometer.
- Deliberate signal mixing - Ideal for those applications whereby the method of steering is by controlling two motors. For example one motor uses X+Y signals and the other uses X-Y signals. This mixing is achieved by internally orientating the signals at 45° to normal. Typical applications may be twin propeller boats, tracked vehicles, or wheelchairs.
- Deliberate signal interaction - Enables reduction in one signal as the other increases. This option is particularly beneficial where it is undesirable to maintain full forward speed while turning and vice versa.

VOLTAGE OUTPUT OPTIONS

SINGLE OUTPUT

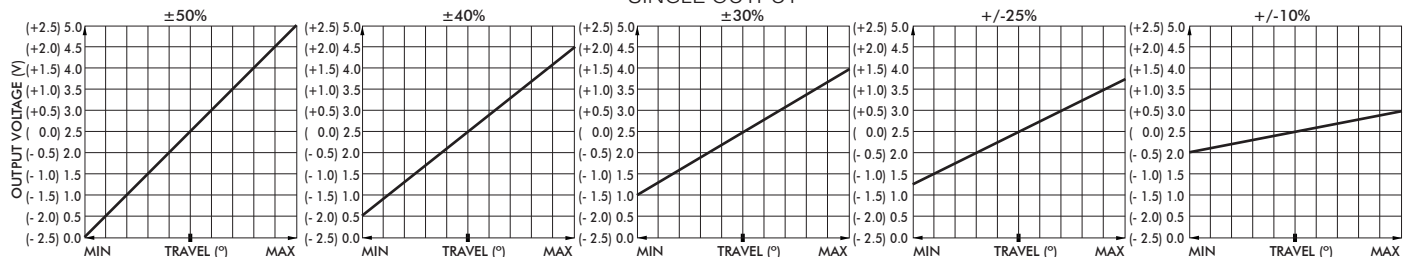

DUAL OUTPUT

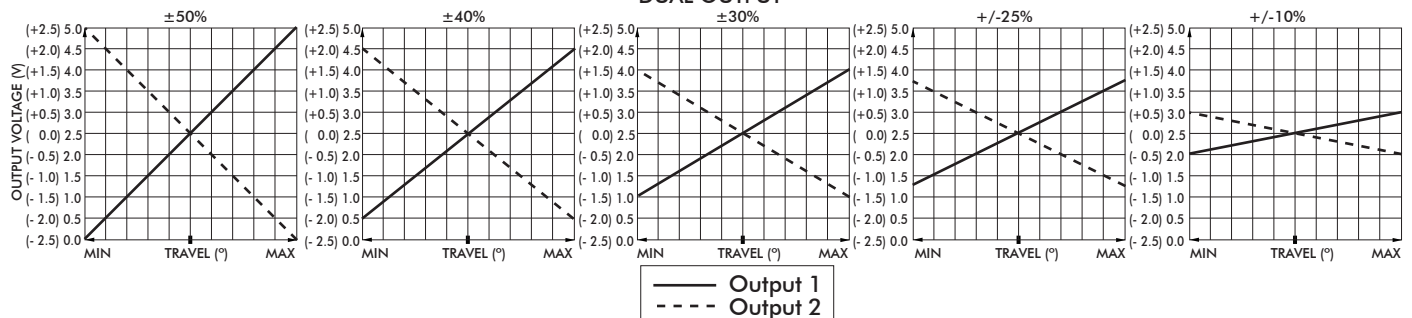

Note: The company reserves the right to change specifications without notice.

Данный компонент на территории Российской Федерации

Вы можете приобрести в компании MosChip.

Для оперативного оформления запроса Вам необходимо перейти по данной ссылке:

<http://moschip.ru/get-element>

Вы можете разместить у нас заказ для любого Вашего проекта, будь то серийное производство или разработка единичного прибора.

В нашем ассортименте представлены ведущие мировые производители активных и пассивных электронных компонентов.

Нашей специализацией является поставка электронной компонентной базы двойного назначения, продукции таких производителей как XILINX, Intel (ex.ALTERA), Vicor, Microchip, Texas Instruments, Analog Devices, Mini-Circuits, Amphenol, Glenair.

Сотрудничество с глобальными дистрибьюторами электронных компонентов, предоставляет возможность заказывать и получать с международных складов практически любой перечень компонентов в оптимальные для Вас сроки.

На всех этапах разработки и производства наши партнеры могут получить квалифицированную поддержку опытных инженеров.

Система менеджмента качества компании отвечает требованиям в соответствии с ГОСТ Р ИСО 9001, ГОСТ РВ 0015-002 и ЭС РД 009

Офис по работе с юридическими лицами:

105318, г.Москва, ул.Щербаковская д.3, офис 1107, 1118, ДЦ «Щербаковский»

Телефон: +7 495 668-12-70 (многоканальный)

Факс: +7 495 668-12-70 (доб.304)

E-mail: info@moschip.ru

Skype отдела продаж:

moschip.ru

moschip.ru_4

moschip.ru_6

moschip.ru_9