

N-channel 80 V, 5.2 mΩ typ., 100 A, STripFET™ F7 Power MOSFET in a PowerFLAT™ 5x6 package

Datasheet - production data

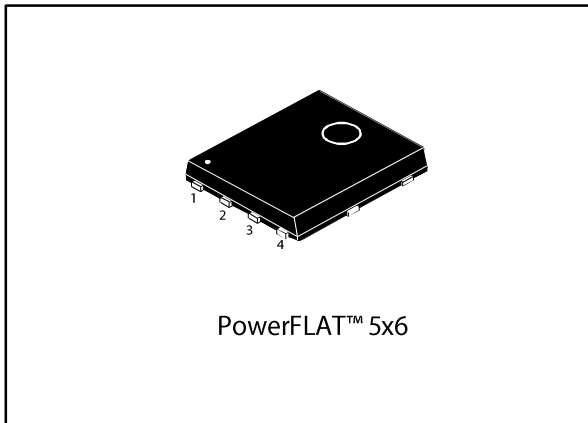
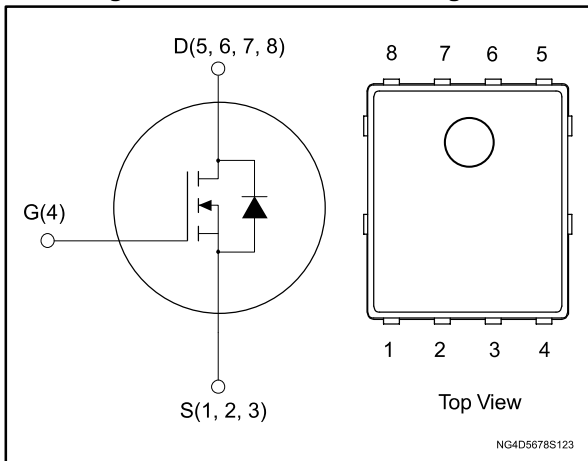

Figure 1: Internal schematic diagram



Features

Order code	V _{DS}	R _{DS(on)max}	I _D	P _{TOT}
STL100N8F7	80 V	6.1 mΩ	100 A	120 W

- Among the lowest R_{DS(on)} on the market
- Excellent figure of merit (FoM)
- Low C_{rss}/C_{iss} ratio for EMI immunity
- High avalanche ruggedness

Applications

- Switching applications

Description

This N-channel Power MOSFET utilizes STripFET™ F7 technology with an enhanced trench gate structure that results in very low on-state resistance, while also reducing internal capacitance and gate charge for faster and more efficient switching.

Table 1: Device summary

Order code	Marking	Package	Packaging
STL100N8F7	100N8F7	PowerFLAT™ 5x6	Tape and reel

Contents

1	Electrical ratings	3
2	Electrical characteristics	4
	2.1 Electrical characteristics (curves)	6
3	Test circuits	8
4	Package information	9
	4.1 PowerFLAT™ 5x6 type C package information	9
	4.2 PowerFLAT™ 5x6 type C packing information.....	11
5	Revision history	13

1 Electrical ratings

Table 2: Absolute maximum ratings

Symbol	Parameter	Value	Unit
V_{DS}	Drain-source voltage	80	V
V_{GS}	Gate-source voltage	± 20	V
$I_D^{(1)}$	Drain current (continuous) at $T_C = 25\text{ }^\circ\text{C}$	100	A
$I_D^{(1)}$	Drain current (continuous) at $T_C = 100\text{ }^\circ\text{C}$	71	A
$I_{DM}^{(1)(2)}$	Drain current (pulsed)	400	A
$I_D^{(3)}$	Drain current (continuous) at $T_{pcb} = 25\text{ }^\circ\text{C}$	20	A
$I_D^{(3)}$	Drain current (continuous) at $T_{pcb} = 100\text{ }^\circ\text{C}$	14	A
$I_{DM}^{(3)(2)}$	Drain current (pulsed)	80	A
$P_{TOT}^{(1)}$	Total dissipation at $T_C = 25\text{ }^\circ\text{C}$	120	W
$P_{TOT}^{(3)}$	Total dissipation at $T_{pcb} = 25\text{ }^\circ\text{C}$	4.8	W
$E_{AS}^{(4)}$	Single pulse avalanche energy	220	mJ
T_J	Operating junction temperature	-55 to 175	$^\circ\text{C}$
T_{stg}	Storage temperature		$^\circ\text{C}$

Notes:

(1) This value is rated according to R_{thj-c} .

(2) Pulse width limited by safe operating area.

(3) This value is rated according to $R_{thj-pcb}$.

(4) Starting $T_J = 25\text{ }^\circ\text{C}$, $I_D = 25\text{ A}$, $V_{DD} = 40\text{ V}$

Table 3: Thermal data

Symbol	Parameter	Value	Unit
$R_{thj-case}$	Thermal resistance junction-case max	1.25	$^\circ\text{C/W}$
$R_{thj-pcb}^{(1)}$	Thermal resistance junction-pcb	31.3	$^\circ\text{C/W}$

Notes:

(1) When mounted on FR-4 board of 1inch², 2oz Cu, $t < 10\text{ sec}$

2 Electrical characteristics

($T_C = 25\text{ °C}$ unless otherwise specified)

Table 4: On /off states

Symbol	Parameter	Test conditions	Min.	Typ.	Max.	Unit
$V_{(BR)DSS}$	Drain-source breakdown voltage	$V_{GS} = 0, I_D = 250\ \mu A$	80			V
I_{DSS}	Zero gate voltage drain current	$V_{GS} = 0, V_{DS} = 80\ V$			1	μA
		$V_{GS} = 0, V_{DS} = 80\ V,$ $T_C = 125\text{ °C}$			10	μA
I_{GSS}	Gate-body leakage current	$V_{DS} = 0, V_{GS} = \pm 20\ V$			± 100	nA
$V_{GS(th)}$	Gate threshold voltage	$V_{DS} = V_{GS}, I_D = 250\ \mu A$	2.5		4.5	V
$R_{DS(on)}$	Static drain-source on-resistance	$V_{GS} = 10\ V, I_D = 10\ A$		5.2	6.1	m Ω

Table 5: Dynamic

Symbol	Parameter	Test conditions	Min.	Typ.	Max.	Unit
C_{iss}	Input capacitance	$V_{GS} = 0, V_{DS} = 40\ V,$ $f = 1\ MHz$	-	3435	-	pF
C_{oss}	Output capacitance		-	653	-	pF
C_{rss}	Reverse transfer capacitance		-	57	-	pF
Q_g	Total gate charge	$V_{DD} = 40\ V, I_D = 20\ A,$ $V_{GS} = 10\ V$ (see Figure 14: "Test circuit for gate charge behavior")	-	46.8	-	nC
Q_{gs}	Gate-source charge		-	23.4	-	nC
Q_{gd}	Gate-drain charge		-	11.2	-	nC

Table 6: Switching times

Symbol	Parameter	Test conditions	Min.	Typ.	Max.	Unit
$t_{d(on)}$	Turn-on delay time	$V_{DD} = 40\ V, I_D = 10\ A,$ $R_G = 4.7\ \Omega, V_{GS} = 10\ V$ (see Figure 13: "Test circuit for resistive load switching times" and Figure 18: "Switching time waveform")	-	49	-	ns
t_r	Rise time		-	95	-	ns
$t_{d(off)}$	Turn-off delay time		-	60	-	ns
t_f	Fall time		-	32	-	ns

Table 7: Source drain diode

Symbol	Parameter	Test conditions	Min.	Typ.	Max.	Unit
$V_{SD}^{(1)}$	Forward on voltage	$V_{GS} = 0, I_{SD} = 20 \text{ A}$	-		1.2	V
t_{rr}	Reverse recovery time	$I_{SD} = 20 \text{ A}, di/dt = 100 \text{ A}/\mu\text{s}$	-	48.6		ns
Q_{rr}	Reverse recovery charge	$V_{DD} = 60 \text{ V}$ (see Figure 15 : <i>"Test circuit for inductive load switching and diode recovery times"</i>)	-	58.6		nC
I_{RRM}	Reverse recovery current		-	2.4		A

Notes:

⁽¹⁾Pulsed: pulse duration = 300 μs , duty cycle 1.5%

2.1 Electrical characteristics (curves)

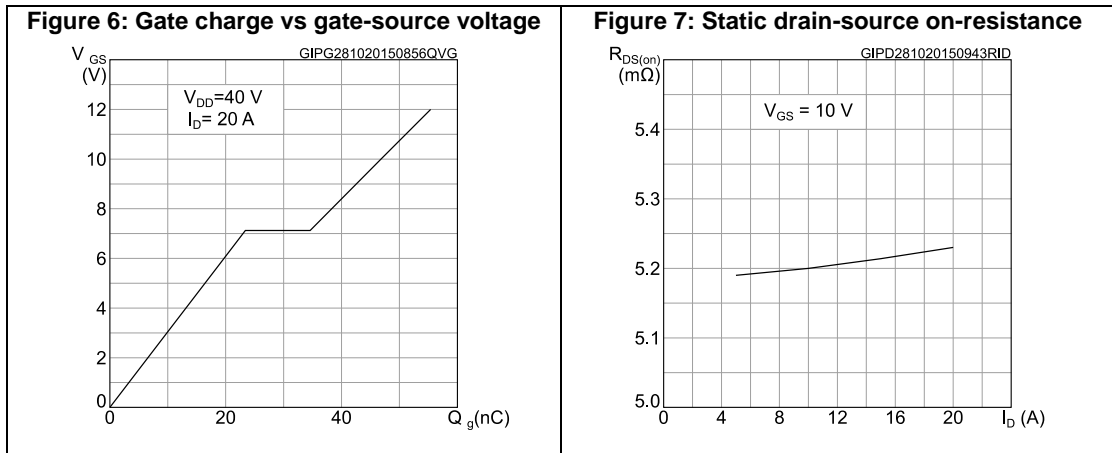
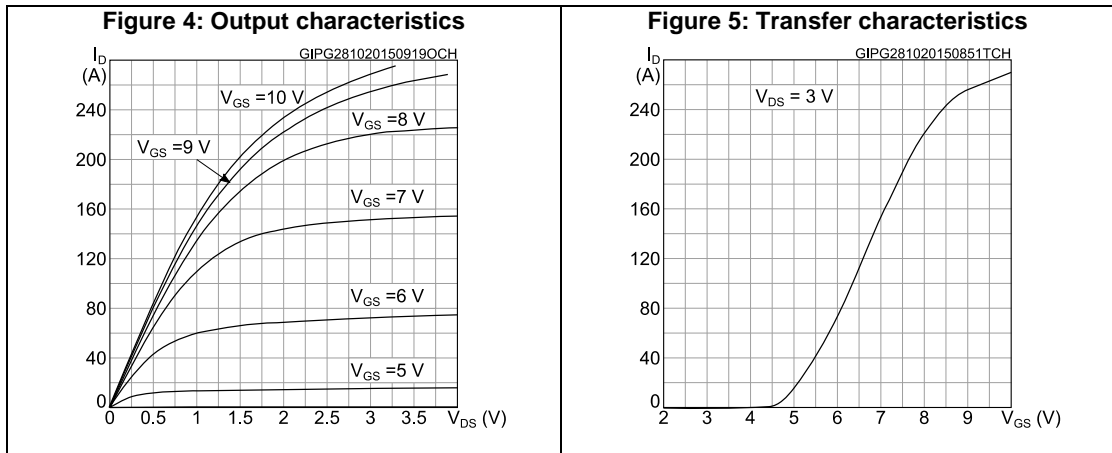
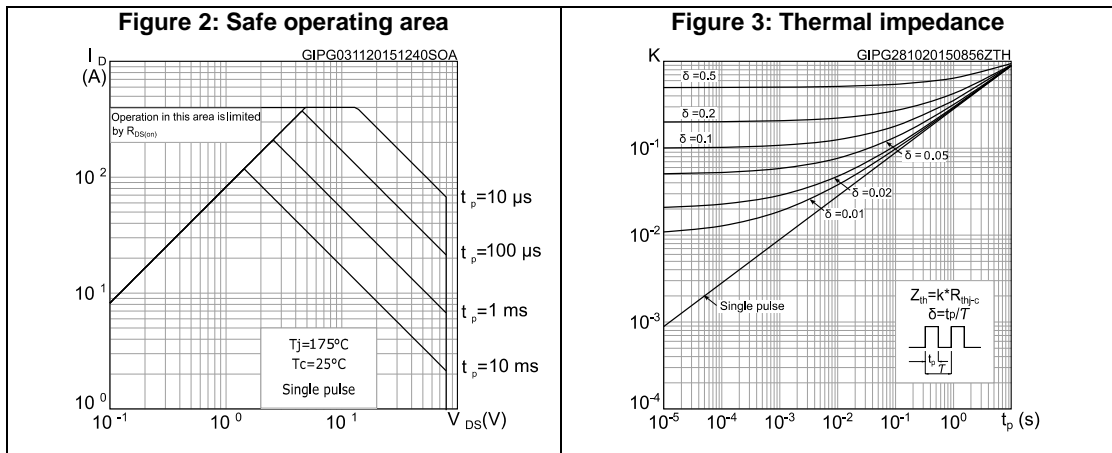

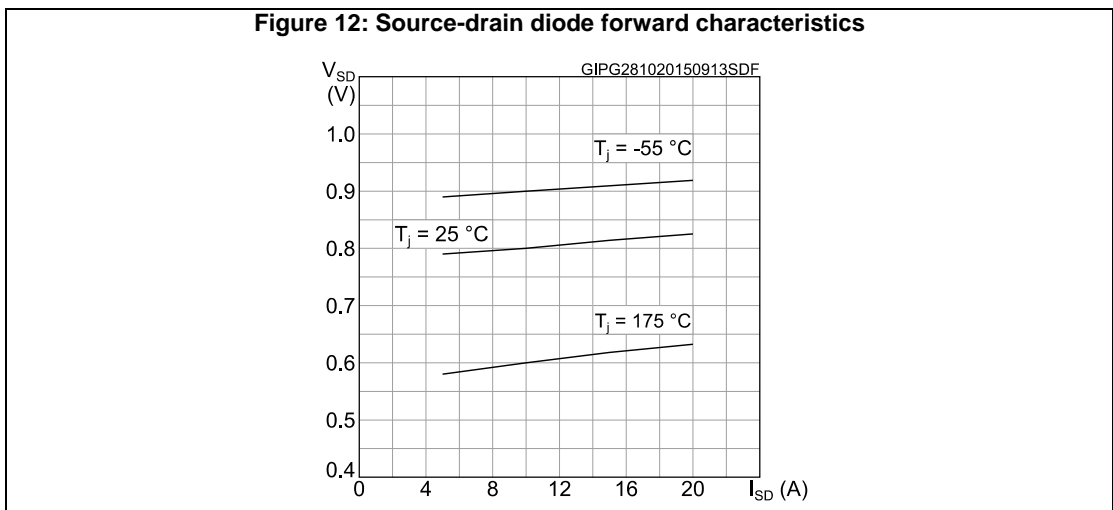
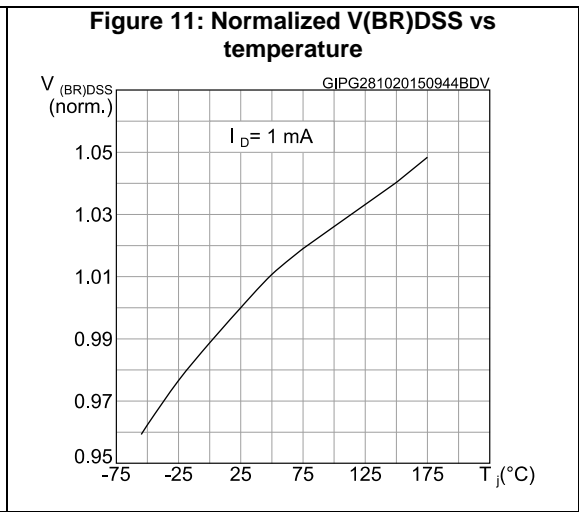
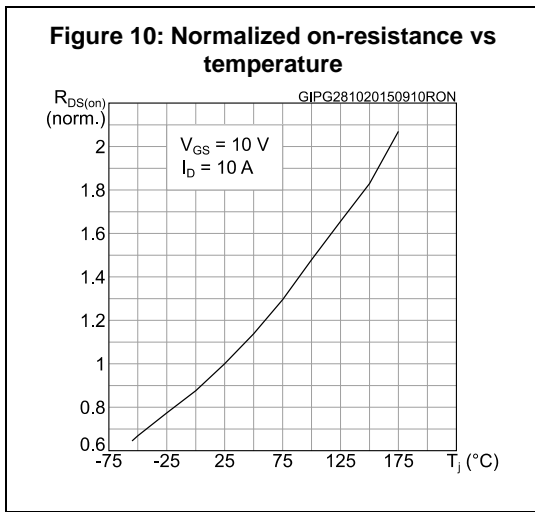
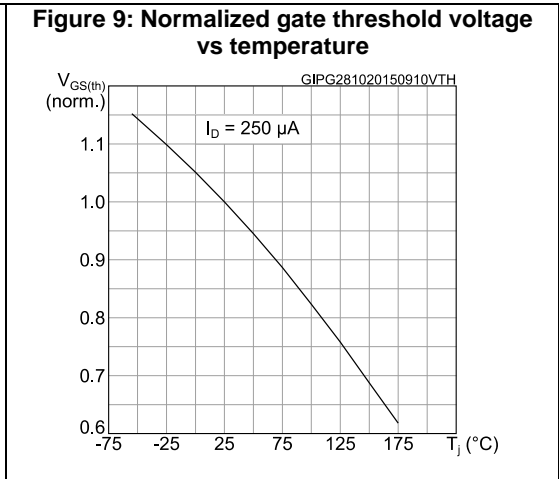
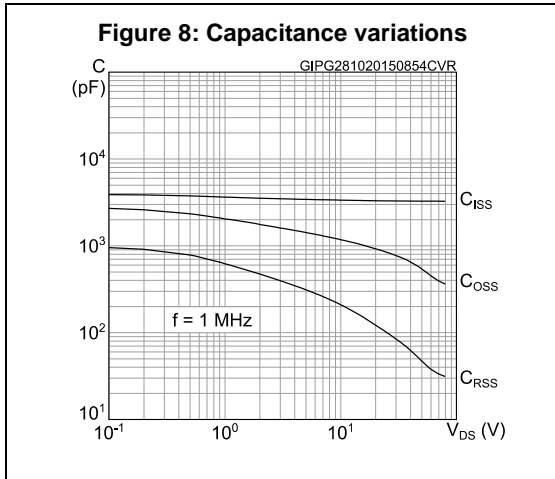

3 Test circuits

Figure 13: Test circuit for resistive load switching times



AM01468v1

Figure 14: Test circuit for gate charge behavior



AM01469v1

Figure 15: Test circuit for inductive load switching and diode recovery times



AM01470v1

Figure 16: Unclamped inductive load test circuit

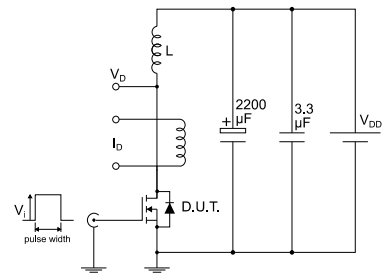

AM01471v1

Figure 17: Unclamped inductive waveform

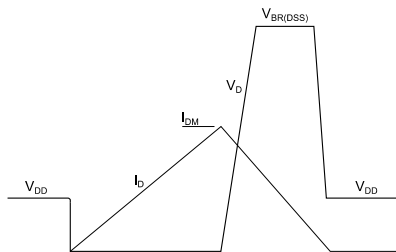

AM01472v1

Figure 18: Switching time waveform

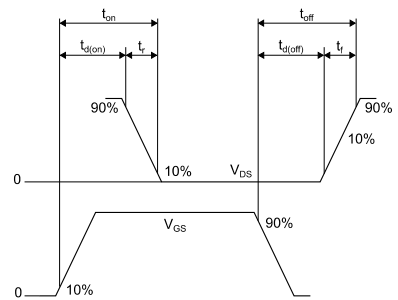

AM01473v1

4 Package information

In order to meet environmental requirements, ST offers these devices in different grades of ECOPACK® packages, depending on their level of environmental compliance. ECOPACK® specifications, grade definitions and product status are available at: www.st.com. ECOPACK® is an ST trademark.

4.1 PowerFLAT™ 5x6 type C package information

Figure 19: PowerFLAT™ 5x6 type C package outline

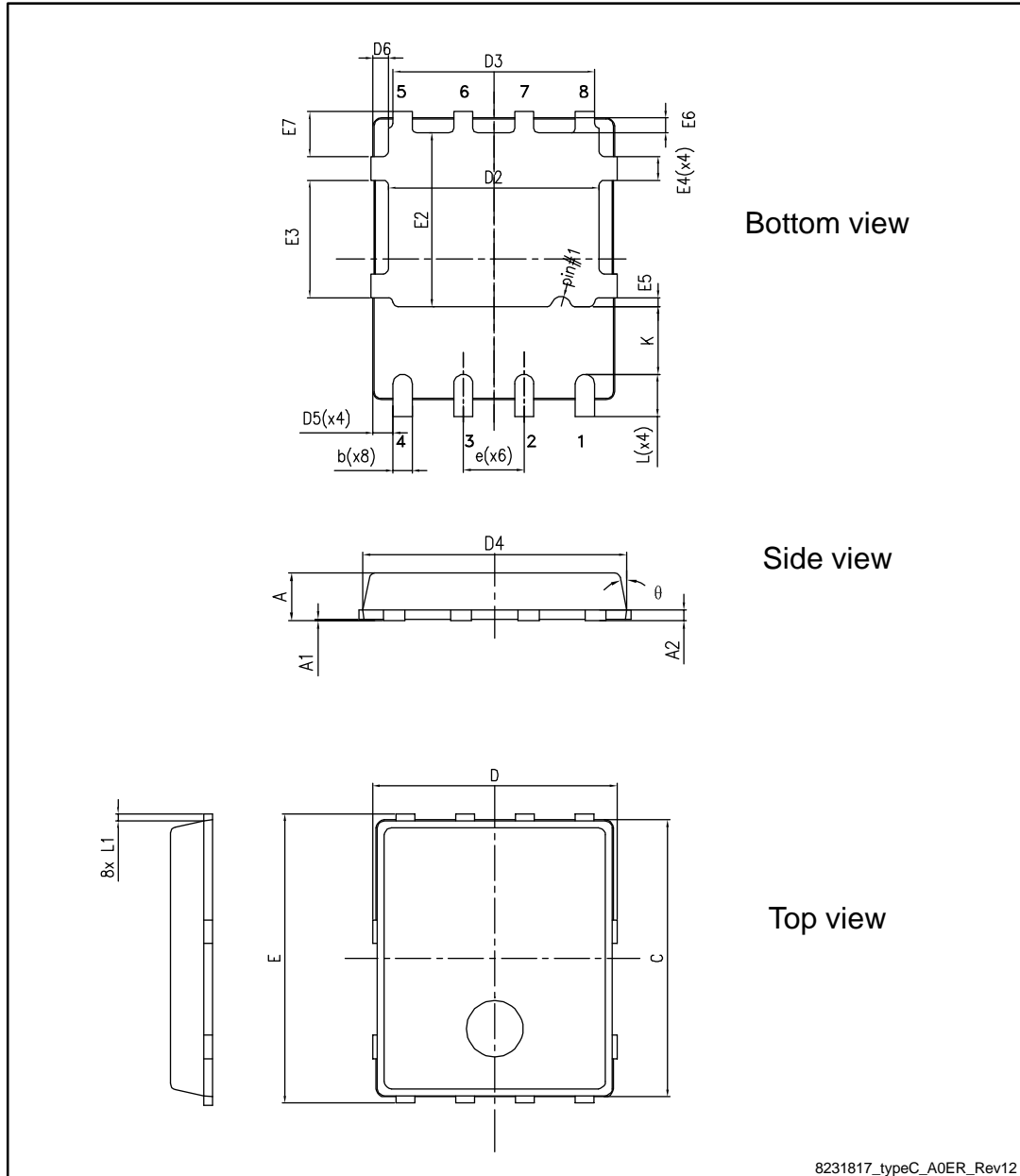

8231817_typeC_A0ER_Rev12

Table 8: PowerFLAT™ 5x6 type C package mechanical data

Dim.	mm		
	Min.	Typ.	Max.
A	0.80		1.00
A1	0.02		0.05
A2		0.25	
b	0.30		0.50
C	5.80	6.00	6.20
D	5.00	5.20	5.40
D2	4.15		4.45
D3	4.05	4.20	4.35
D4	4.80	5.0	5.20
D5	0.25	0.4	0.55
D6	0.15	0.3	0.45
e		1.27	
E	5.95	6.15	6.35
E2	3.50		3.70
E3	2.35		2.55
E4	0.40		0.60
E5	0.08		0.28
E6	0.2	0.325	0.450
E7	0.75	0.90	1.05
K	1.05		1.35
L	0.715		1.015
L1	0.05	0.15	0.25
θ	0°		12°

Figure 20: PowerFLAT™ 5x6 recommended footprint (dimensions are in mm)

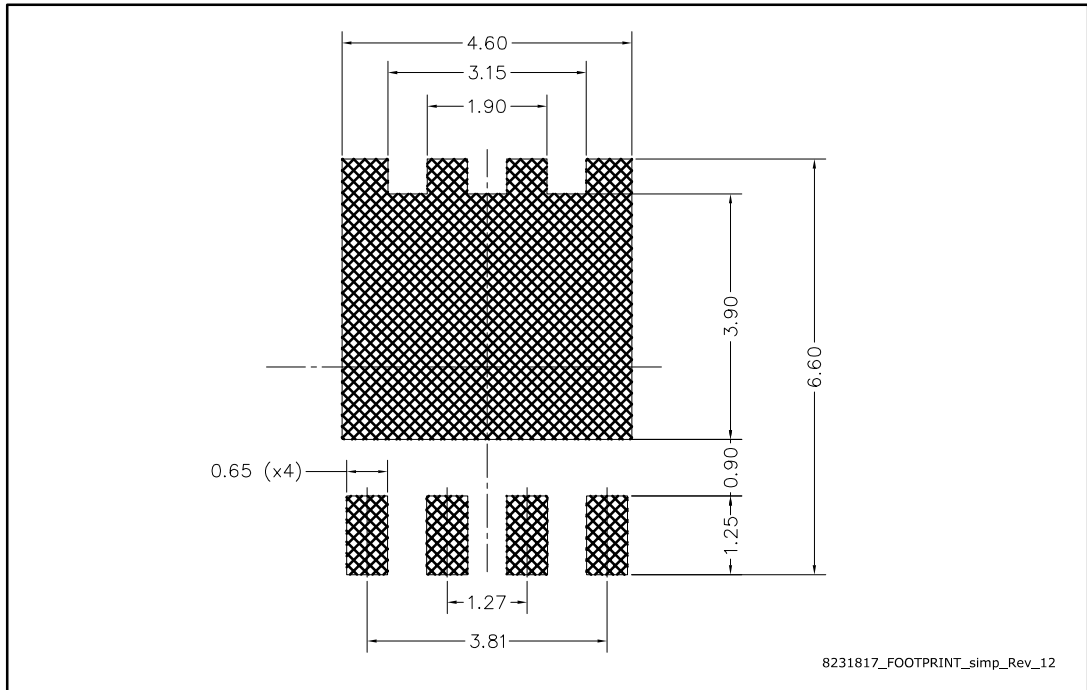

4.2 PowerFLAT™ 5x6 type C packing information

Figure 21: PowerFLAT™ 5x6 tape (dimensions are in mm)

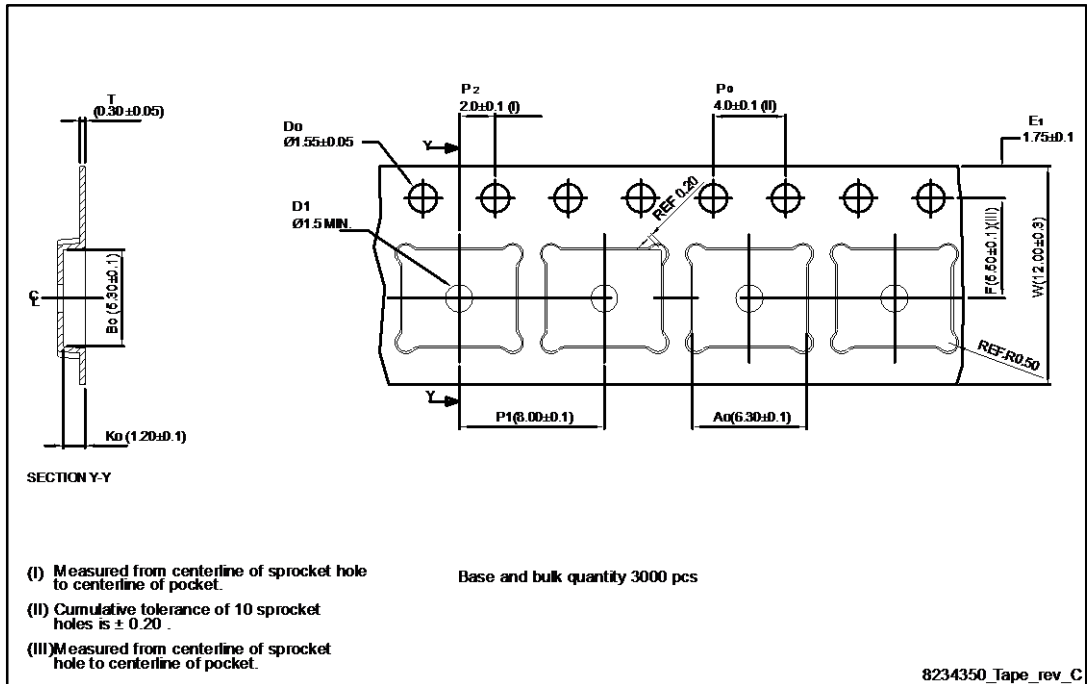

- (I) Measured from centerline of sprocket hole to centerline of pocket.
- (II) Cumulative tolerance of 10 sprocket holes is ± 0.20 .
- (III) Measured from centerline of sprocket hole to centerline of pocket.

Base and bulk quantity 3000 pcs

8234350_Tape_rev_C

Figure 22: PowerFLAT™ 5x6 package orientation in carrier tape

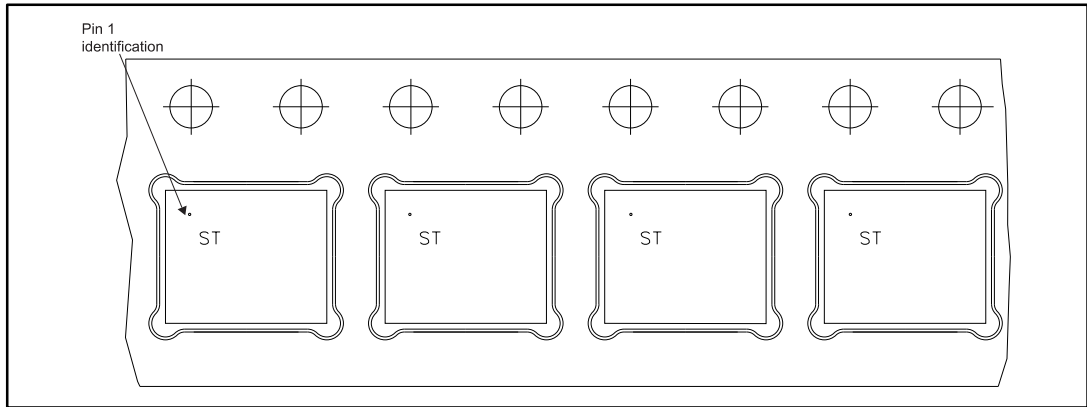
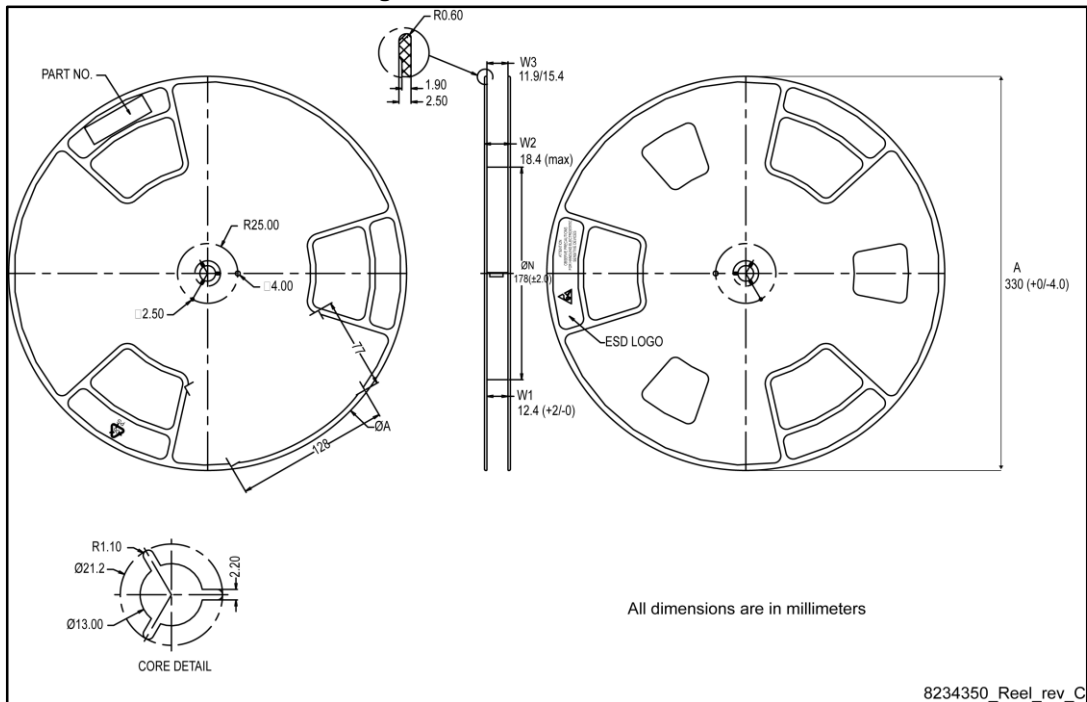

Figure 23: PowerFLAT™ 5x6 reel



8234350_Reel_rev_C

5 Revision history

Table 9: Document revision history

Date	Revision	Changes
21-Oct-2014	1	Initial release.
03-Nov-2015	2	Modified: Table 2: "Absolute maximum ratings" , Table 5: "Dynamic", Table 6: "Switching times" and Table 7: "Source drain diode". Added: Section 4.1: "Electrical characteristics (curves)". Minor text changes
03-Dec-2015	3	Document status promoted from preliminary to production data.

IMPORTANT NOTICE – PLEASE READ CAREFULLY

STMicroelectronics NV and its subsidiaries ("ST") reserve the right to make changes, corrections, enhancements, modifications, and improvements to ST products and/or to this document at any time without notice. Purchasers should obtain the latest relevant information on ST products before placing orders. ST products are sold pursuant to ST's terms and conditions of sale in place at the time of order acknowledgement.

Purchasers are solely responsible for the choice, selection, and use of ST products and ST assumes no liability for application assistance or the design of Purchasers' products.

No license, express or implied, to any intellectual property right is granted by ST herein.

Resale of ST products with provisions different from the information set forth herein shall void any warranty granted by ST for such product.

ST and the ST logo are trademarks of ST. All other product or service names are the property of their respective owners.

Information in this document supersedes and replaces information previously supplied in any prior versions of this document.

© 2015 STMicroelectronics – All rights reserved

Данный компонент на территории Российской Федерации

Вы можете приобрести в компании MosChip.

Для оперативного оформления запроса Вам необходимо перейти по данной ссылке:

<http://moschip.ru/get-element>

Вы можете разместить у нас заказ для любого Вашего проекта, будь то серийное производство или разработка единичного прибора.

В нашем ассортименте представлены ведущие мировые производители активных и пассивных электронных компонентов.

Нашей специализацией является поставка электронной компонентной базы двойного назначения, продукции таких производителей как XILINX, Intel (ex.ALTERA), Vicor, Microchip, Texas Instruments, Analog Devices, Mini-Circuits, Amphenol, Glenair.

Сотрудничество с глобальными дистрибьюторами электронных компонентов, предоставляет возможность заказывать и получать с международных складов практически любой перечень компонентов в оптимальные для Вас сроки.

На всех этапах разработки и производства наши партнеры могут получить квалифицированную поддержку опытных инженеров.

Система менеджмента качества компании отвечает требованиям в соответствии с ГОСТ Р ИСО 9001, ГОСТ РВ 0015-002 и ЭС РД 009

Офис по работе с юридическими лицами:

105318, г.Москва, ул.Щербаковская д.3, офис 1107, 1118, ДЦ «Щербаковский»

Телефон: +7 495 668-12-70 (многоканальный)

Факс: +7 495 668-12-70 (доб.304)

E-mail: info@moschip.ru

Skype отдела продаж:

moschip.ru

moschip.ru_4

moschip.ru_6

moschip.ru_9