

**LOW VOLTAGE P.C. BOARD MOUNT LOW PROFILE
162/164 SERIES**

Key Features:

- Both series operate on 50/60 Hz current.
- Low profile, split bobbin design.
- Dual winding secondaries, non-concentrically wound.
- Units are designed so that all windings must be used.
- Low primary to secondary coupling - no electro static shield required.
- One year warranty.
- High insulation - Hipot of 2,500V RMS.
- Class B insulation - 130 degrees C.
- No mounting hardware required on 1.1 and 2.4 VA sizes. Two hole mounting on 6, 12 and 20V sizes. Four hole mounting on 36VA size (mounting screws not provided).
- P.C. board mount with industry standard pin spacing.
- c UL us recognized.
- For more information on this series, go to:
<http://www.hammondmfg.com/162.htm>



Single Primary - 164 Series

Dual Primary - 162 Series

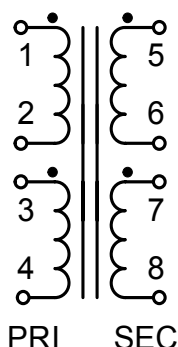
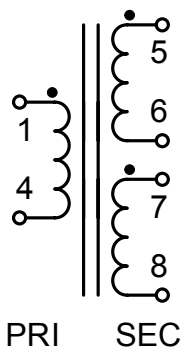

Part No. Single Pri. 115V	Part No. Dual Pri. 115/230V	Size VA	Secondary (RMS)	
			Series	Parallel
164D10	162D10	1.1	10V C.T. @ .11A	5V @ .22A
164E10	162E10	2.4	10V C.T. @ .25A	5V @ .5A
164F10	162F10	6	10V C.T. @ .6A	5V @ 1.2A
164G10	162G10	12	10V C.T. @ 1.2A	5V @ 2.4A
164H10	162H10	20	10V C.T. @ 2A	5V @ 4A
164J10	162J10	36	10V C.T. @ 3.6A	5V @ 7.2A
164D12	162D12	1.1	12.6V C.T. @ .09A	6.3V @ .18A
164E12	162E12	2.4	12.6V C.T. @ .2A	6.3V @ .4A
164F12	162F12	6	12.6V C.T. @ .5A	6.3V @ 1A
164G12	162G12	12	12.6V C.T. @ 1A	6.3V @ 2A
164H12	162H12	20	12.6V C.T. @ 1.6A	6.3V @ 3.2A
164J12	162J12	36	12.6V C.T. @ 2.85A	6.3V @ 5.7A
164D16	162D16	1.1	16V C.T. @ .07A	8V @ .14A
164E16	162E16	2.4	16V C.T. @ .15A	8V @ .3A
164F16	162F16	6	16V C.T. @ .4A	8V @ .8A
164G16	162G16	12	16V C.T. @ .8A	8V @ 1.6A
164H16	162H16	20	16V C.T. @ 1.25A	8V @ 2.5A
164J16	162J16	36	16V C.T. @ 2.25A	8V @ 4.5A
164D20	162D20	1.1	20V C.T. @ .055A	10V @ .11A
164E20	162E20	2.4	20V C.T. @ .12A	10V @ .24A
164F20	162F20	6	20V C.T. @ .3A	10V @ .6A
164G20	162G20	12	20V C.T. @ .6A	10V @ 1.2A
164H20	162H20	20	20V C.T. @ 1A	10V @ 2A
164J20	162J20	36	20V C.T. @ 1.8A	10V @ 3.6A
164D24	162D24	1.1	24V C.T. @ .045A	12V @ .09A
164E24	162E24	2.4	24V C.T. @ .1A	12V @ .2A
164F24	162F24	6	24V C.T. @ .25A	12V @ .5A
164G24	162G24	12	24V C.T. @ .5A	12V @ 1A
164H24	162H24	20	24V C.T. @ .8A	12V @ 1.6A
164J24	162J24	36	24V C.T. @ 1.5A	12V @ 3A
164D28	162D28	1.1	28V C.T. @ .04A	14V @ .08A
164E28	162E28	2.4	28V C.T. @ .085A	14V @ .17A
164F28	162F28	6	28V C.T. @ .2A	14V @ .4A
164G28	162G28	12	28V C.T. @ .42A	14V @ .84A
164H28	162H28	20	28V C.T. @ .7A	14V @ 1.4A
164J28	162J28	36	28V C.T. @ 1.3A	14V @ 2.6A
164D36	162D36	1.1	36V C.T. @ .03A	18V @ .06A
164E36	162E36	2.4	36V C.T. @ .065A	18V @ .13A
164F36	162F36	6	36V C.T. @ .17A	18V @ .34A
164G36	162G36	12	36V C.T. @ .35A	18V @ .7A
164H36	162H36	20	36V C.T. @ .55A	18V @ 1.1A
164J36	162J36	36	36V C.T. @ 1A	18V @ 2A
164D48	162D48	1.1	48V C.T. @ .023A	24V @ .046A
164E48	162E48	2.4	48V C.T. @ .05A	24V @ .1A
164F48	162F48	6	48V C.T. @ .125A	24V @ .25A
164G48	162G48	12	48V C.T. @ .25A	24V @ .5A
164H48	162H48	20	48V C.T. @ .4A	24V @ .8A
164J48	162J48	36	48V C.T. @ .75A	24V @ 1.5A
164D56	162D56	1.1	56V C.T. @ .02A	28V @ .04A
164E56	162E56	2.4	56V C.T. @ .045A	28V @ .09A
164F56	162F56	6	56V C.T. @ .11A	28V @ .22A
164G56	162G56	12	56V C.T. @ .22A	28V @ .44A
164H56	162H56	20	56V C.T. @ .35A	28V @ .7A
164J56	162J56	36	56V C.T. @ .65A	28V @ 1.3A
164D120	162D120	1.1	120V C.T. @ .01A	60V @ .02A
164E120	162E120	2.4	120V C.T. @ .02A	60V @ .04A
164F120	162F120	6	120V C.T. @ .05A	60V @ .1A
164G120	162G120	12	120V C.T. @ .1A	60V @ .2A
164H120	162H120	20	120V C.T. @ .16A	60V @ .32A
164J120	162J120	36	120V C.T. @ .3A	60V @ .6A

www.hammondmfg.com

Connection Information 162 / 164 Series Transformers

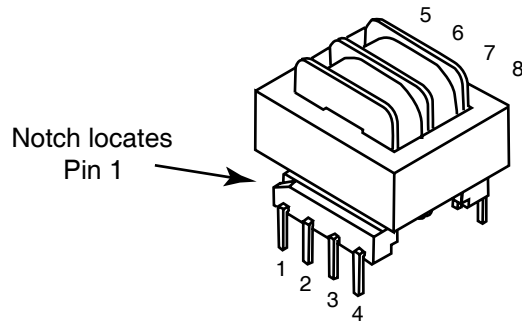

Pins 2 & 3 are omitted on the 164 series (single primary)

Primary Connections - 162 Series Transformers

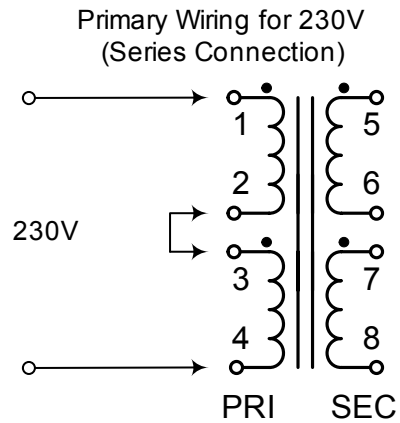
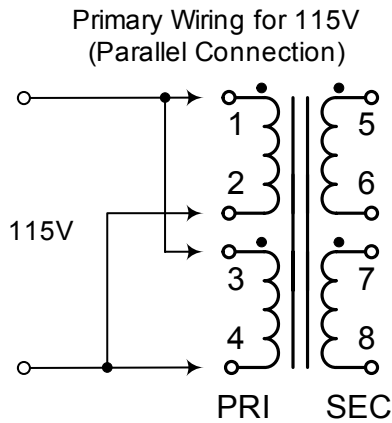

Primary Connections - 164 Series Transformers

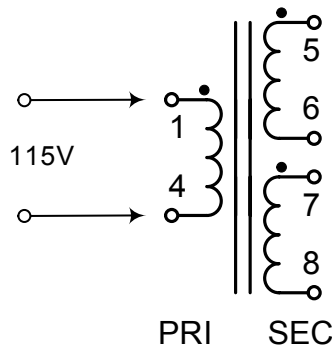

Secondary Connections - both 162 & 164 Series Transformers

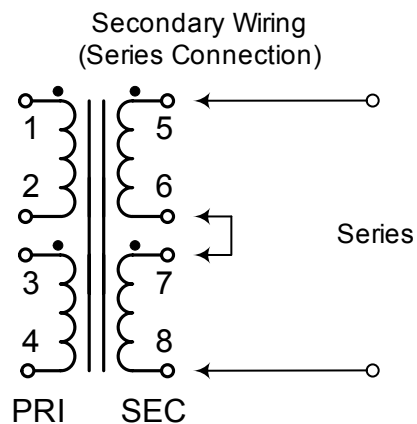
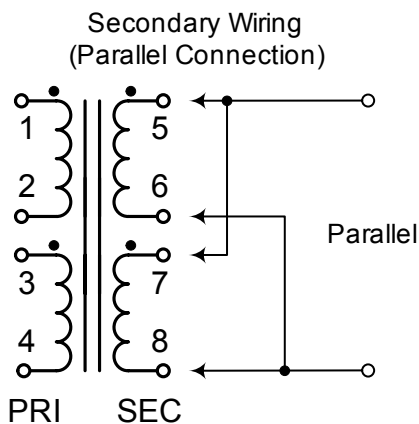

Данный компонент на территории Российской Федерации

Вы можете приобрести в компании MosChip.

Для оперативного оформления запроса Вам необходимо перейти по данной ссылке:

<http://moschip.ru/get-element>

Вы можете разместить у нас заказ для любого Вашего проекта, будь то серийное производство или разработка единичного прибора.

В нашем ассортименте представлены ведущие мировые производители активных и пассивных электронных компонентов.

Нашей специализацией является поставка электронной компонентной базы двойного назначения, продукции таких производителей как XILINX, Intel (ex.ALTERA), Vicor, Microchip, Texas Instruments, Analog Devices, Mini-Circuits, Amphenol, Glenair.

Сотрудничество с глобальными дистрибьюторами электронных компонентов, предоставляет возможность заказывать и получать с международных складов практически любой перечень компонентов в оптимальные для Вас сроки.

На всех этапах разработки и производства наши партнеры могут получить квалифицированную поддержку опытных инженеров.

Система менеджмента качества компании отвечает требованиям в соответствии с ГОСТ Р ИСО 9001, ГОСТ РВ 0015-002 и ЭС РД 009

Офис по работе с юридическими лицами:

105318, г.Москва, ул.Щербаковская д.3, офис 1107, 1118, ДЦ «Щербаковский»

Телефон: +7 495 668-12-70 (многоканальный)

Факс: +7 495 668-12-70 (доб.304)

E-mail: info@moschip.ru

Skype отдела продаж:

moschip.ru

moschip.ru_4

moschip.ru_6

moschip.ru_9