

0.6V ENHANCED ADJUSTABLE PRECISION SHUNT REGULATOR

NEW PRODUCT

Description

The ZXRE160 is a 5-terminal adjustable shunt regulator offering excellent temperature stability and output handling capability. This device offers an enhancement to the ZXRE060 part for use in a comparator mode applications.

In shunt regulator mode, the ZXRE160 simplifies the design of isolated low voltage DC-DC regulators. With its low 0.6V FB pin, it can control the regulation of rails as low 0.6V. This makes the part ideal for state of the art microprocessor, DSP and PLD core voltage POL converters.

The device open-collector output can operate from 0.2V to 18V and regulated output voltage can be set by selection of two external divider resistors. Separating the input from the open collector output enables the ZXRE160 to be used to make low-cost low drop-out regulators operating at low input voltages.

The ZXRE160 is available in two grades with initial tolerances of 0.5% and 1% for the A and standard grades respectively. It is available in space saving low profile 5 pin SC70/SOT353, thin TSOT25 and very small DFN1520 packages.

Features

- Low reference voltage ($V_{FB} = 0.6V$)
- $-40^{\circ}C$ to $+125^{\circ}C$ temperature range
- Reference voltage tolerance at $+25^{\circ}C$
- 0.5% ZXRE160A
- 1% ZXRE160
- Typical temperature drift
- <4 mV ($0^{\circ}C$ to $+70^{\circ}C$)
- <6 mV ($-40^{\circ}C$ to $+85^{\circ}C$)
- $<12mV$ ($-40^{\circ}C$ to $+125^{\circ}C$)
- 0.2V to 18V open-collector output
- High power supply rejection
- ($>45dB$ at 300kHz)
- **Totally Lead-Free & Fully RoHS Compliant (Notes 1 & 2)**
- **Halogen and Antimony Free. "Green" Device (Note 3)**

Notes: 1. No purposely added lead. Fully EU Directive 2002/95/EC (RoHS) & 2011/65/EU (RoHS 2) compliant.
 2. See <http://www.diodes.com> for more information about Diodes Incorporated's definitions of Halogen- and Antimony-free, "Green" and Lead-free.
 3. Halogen- and Antimony-free "Green" products are defined as those which contain $<900ppm$ bromine, $<900ppm$ chlorine ($<1500ppm$ total Br + Cl) and $<1000ppm$ antimony compounds.

Pin Assignments

ZXRE160_H5 (SC70/SOT353) and
ZXRE160_ET5 (TSOT25)



ZXRE160_FT4 (X2-DFN1520-6)



Exposed flag floating or
connect to GND

Applications

- Isolated DC-DC converters
- Core voltage POL
- Low Voltage Low-Dropout linear regulators
- Shunt regulators
- Adjustable voltage reference

Typical Applications Circuit

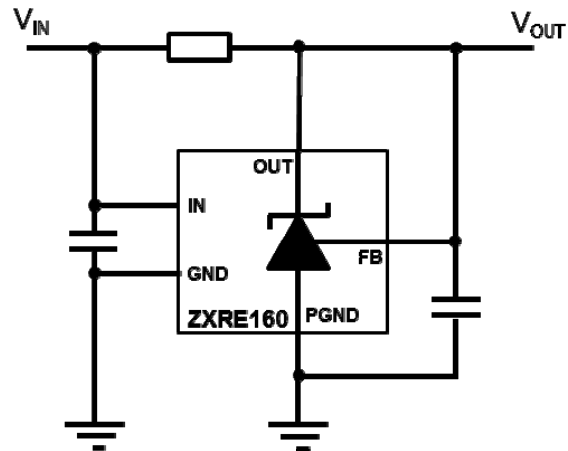

Pin Descriptions

Pin Name	Package Name Pin Number		Function
	SC70/ SOT353, TSOT25	X2-DFN1520-6	
PGND	1	1	Power Ground: Ground return for emitter of output transistor: Connect PGND and GND together.
—	—	2	No connection
OUT	5	3	Output: Connect a capacitor close to device between OUT and GND for closed loop stability. See the <i>Applications Information</i> section.
FB	4	4	Feedback Input. Threshold voltage 600mV nominal.
GND	2	5	Analog Ground: Ground return for reference and amplifier: Connect GND and PGND together.
IN	3	6	Supply Input: Connect a 0.1µF ceramic capacitor close to the device from IN to GND.
—	—	Flag	Floating or connect to GND

Functional Block Diagram



The ZXRE160 differs from most other shunt regulators in that it has separate input and output pins and a low voltage reference. This enables it to regulate rails down to 600mV and makes the part ideal for isolated power supply applications that use opto-couplers in the feedback loop and where the open-collector output is required to operate down to voltages as low as 200mV.

The wide input voltage range of 2V to 18V and output voltage range of 0.2V to 18V enables the ZXRE160 to be powered from an auxiliary rail, while controlling a master rail which is above the

auxiliary rail voltage, or below the minimum V_{IN} voltage. This allows it to operate as a low-dropout voltage regulator for microprocessor/DSP/PLD cores.

As with other shunt regulators (and shunt references), the ZXRE160 compares its internal amplifier FB pin to a high accuracy internal reference; if FB is below the reference then OUT turns off, but if FB is above the reference then OUT sinks current – up to a maximum of 15mA.

Absolute Maximum Ratings (Voltages to GND, @T_A = +25°C, unless otherwise specified.)

Symbol	Parameter	Rating	Unit
V _{IN}	IN Voltage relative to GND	20	V
V _{OUT}	OUT Voltage relative to GND	20	V
V _{FB}	FB Voltage relative to GND	20	V
P _{GND}	PGND Voltage relative to GND	-0.3 to +0.3	V
I _{OUT}	OUT Pin Current	20	mA
T _J	Operating Junction Temperature	-40 to 150	°C
T _{ST}	Storage Temperature	55 to 150	°C

These are stress ratings only. Operation outside the absolute maximum ratings may cause device failure. Operation at the absolute maximum rating for extended periods may reduce device reliability.

Semiconductor devices are ESD sensitive and may be damaged by exposure to ESD events. Suitable ESD precautions should be taken when handling and transporting these devices.

Package Thermal Data

Package	θ _{JA}	P _{DIS} T _A = 25°C, T _J = 150°C
SC70/SOT353	400°C/W	310mW
TSOT25	250°C/W	500mW
X2-DFN1520-6	TBD	TBD

Recommended Operating Conditions (@T_A = +25°C, unless otherwise specified.)

Symbol	Parameter	Min	Max	Units
V _{IN}	IN Voltage Range (0 to +125°C)	2	18	V
V _{IN}	IN Voltage Range (-40°C to 0°C)	2.2	18	
V _{OUT}	OUT Voltage Range	0.2	18	
I _{OUT}	OUT Pin Current	0.3	15	mA
T _A	Operating Ambient Temperature Range	-40	+125	°C

Electrical Characteristics (@ $T_A = +25^\circ\text{C}$, $V_{DD} = 3\text{V}$, unless otherwise specified.)

$T_A = +25^\circ\text{C}$, $V_{IN} = 3.3\text{V}$, $V_{OUT} = V_{FB}$, $I_{OUT} = 5\text{mA}$, unless otherwise specified.) (Note 4)

Symbol	Parameter	Conditions		Min	Typ	Max	Units		
V_{FB}	Feedback voltage			ZXRE160A	0.597	0.6	0.603	V	
				ZXRE160	0.594	0.6	0.606		
		$T_A = 0^\circ\text{C}$ to $+85^\circ\text{C}$		ZXRE160A	0.595		0.605		
				ZXRE160	0.592		0.608		
		$T_A = -40^\circ\text{C}$ to $+85^\circ\text{C}$		ZXRE160A	0.594		0.606		
				ZXRE160	0.591		0.609		
		$T_A = -40^\circ\text{C}$ to $+125^\circ\text{C}$		ZXRE160A	0.593		0.607		
				ZXRE160	0.590		0.610		
FB_{LOAD}	Feedback pin load regulation	$I_{OUT} = 1$ to 15mA			3.8	6	mV		
				$T_A = -40$ to $+125^\circ\text{C}$					10
FB_{LINE}	Feedback pin line regulation	$V_{IN} = 2\text{V}$ to 18V			0.3	1	mV		
		$V_{IN} = 2.2\text{V}$ to 18V		$T_A = -40$ to $+125^\circ\text{C}$				1.5	
FB_{OVR}	Output voltage regulation	$V_{OUT} = 0.2\text{V}$ to 18V , $I_{OUT} = 1\text{mA}$ (Ref. Figure 1)				1	mV		
				$T_A = -40$ to $+125^\circ\text{C}$				1.5	
I_{FB}	FB input bias current	$V_{IN} = 18\text{V}$			-45		nA		
				$T_A = -40$ to $+125^\circ\text{C}$		-200		0	
				$V_{FB} = 0.7\text{V}$		-50		50	
I_{IN}	Input current	$V_{IN} = 2\text{V}$ to 18V		$I_{OUT} = 0.3\text{mA}$			0.35	0.7	mA
						$T_A = -40$ to $+125^\circ\text{C}$			
		$V_{IN} = 2\text{V}$ to 18V		$I_{OUT} = 10\text{mA}$			0.48	1	mA
						$T_A = -40$ to $+125^\circ\text{C}$			
		$V_{IN} = 18\text{V}$, $I_{OUT} = 0.3\text{mA}$		$V_{FB} = 0.7\text{V}$				3	
$I_{OUT(LK)}$	OUT leakage current	$V_{IN} = 18\text{V}$, $V_{OUT} = 18\text{V}$, $V_{FB} = 0\text{V}$				0.1	μA		
				$T_A = +125^\circ\text{C}$				1	
Z_{OUT}	Dynamic Output Impedance	$I_{OUT} = 1$ to 15mA $f < 1\text{kHz}$			0.25	0.4	Ω		
				$T_A = -40$ to $+125^\circ\text{C}$				0.6	
PSRR	Power supply rejection ratio	$F = 300\text{kHz}$ $V_{AC} = 0.3V_{PP}$			>45		dB		
BW	Amplifier Unity Gain Frequency	Ref: Figure 2			600		kHz		
G	Amplifier Transconductance				5000		mA/V		

Note: 4. Production testing of the device is performed at $+25^\circ\text{C}$. Functional operation of the device and parameters specified over the operating temperature range are guaranteed by design, characterization and process control.

Typical Characteristics

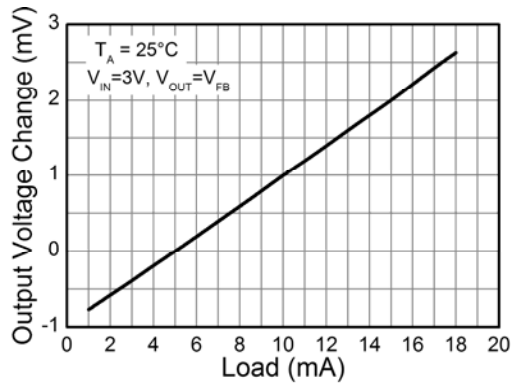

Load Regulation

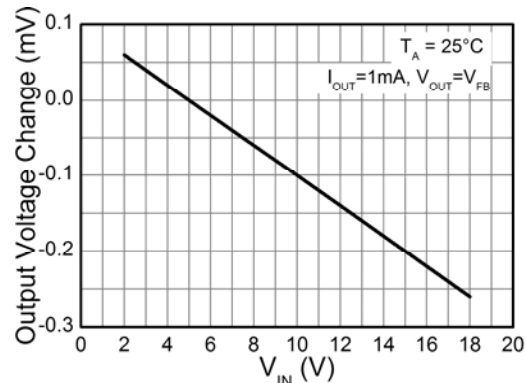

Line Regulation

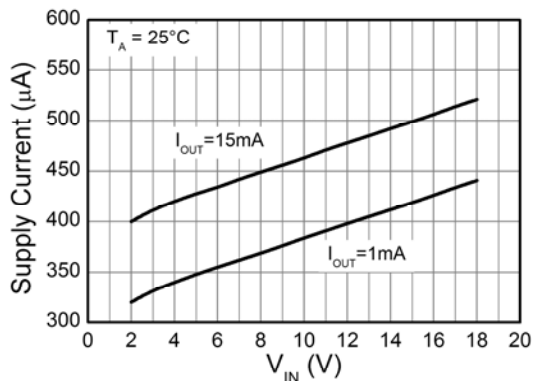

Supply Current vs Input Voltage

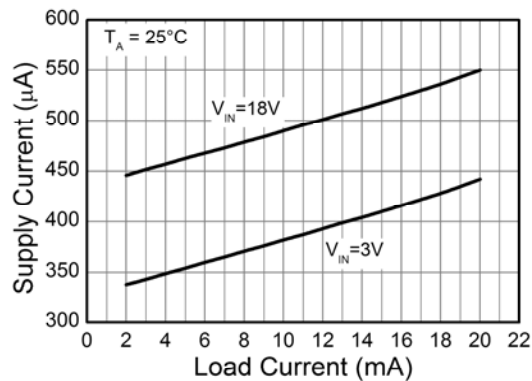

Supply Current vs Load Current

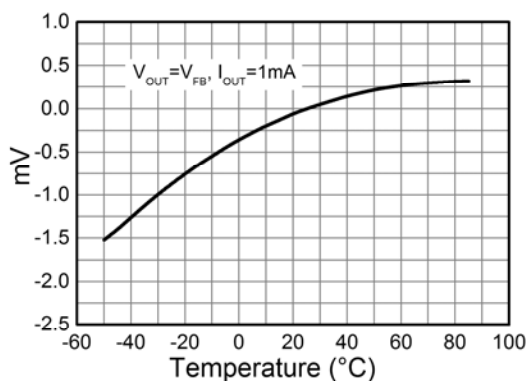

OUT Voltage Change with Temperature

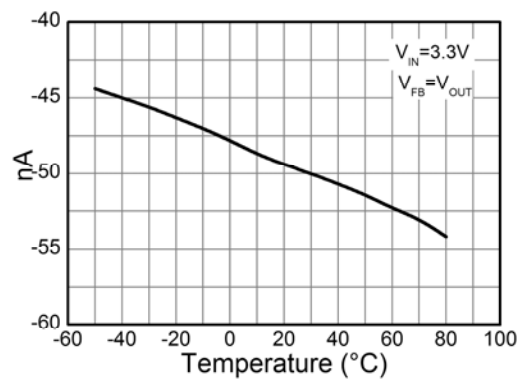

FB Bias Current vs Temperature

Typical Operating Characteristics

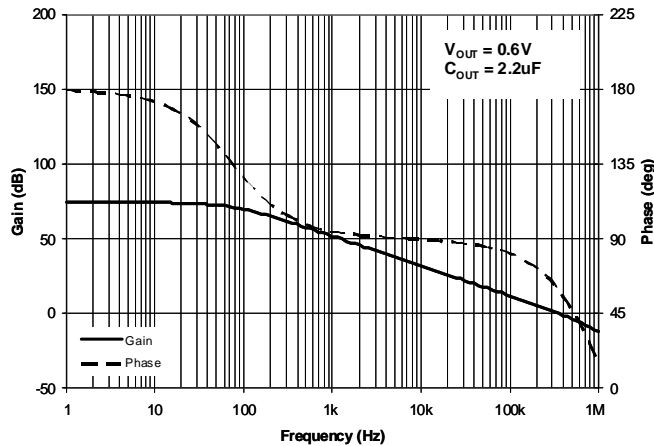

Gain and Phase vs Frequency, $V_{OUT}=0.6V$

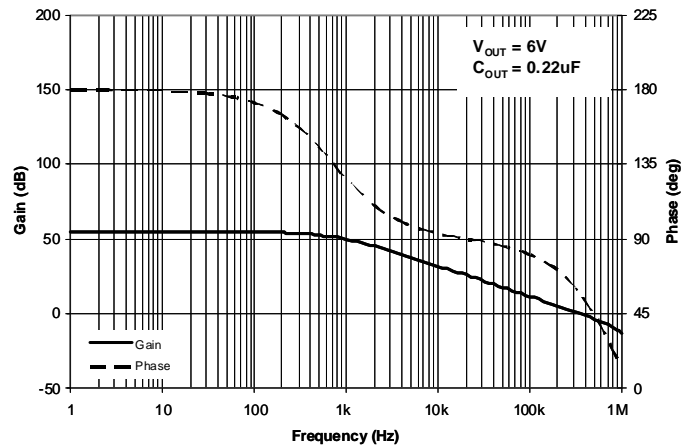

Gain and Phase vs Frequency, $V_{OUT}=6V$

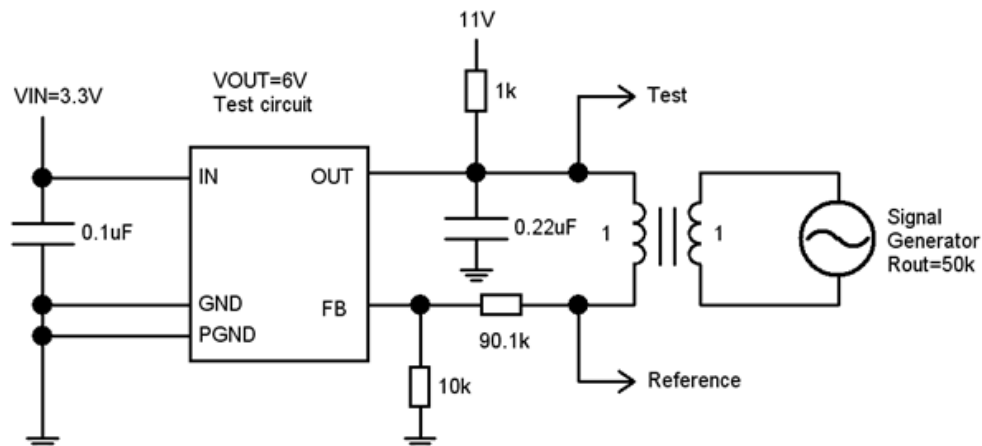
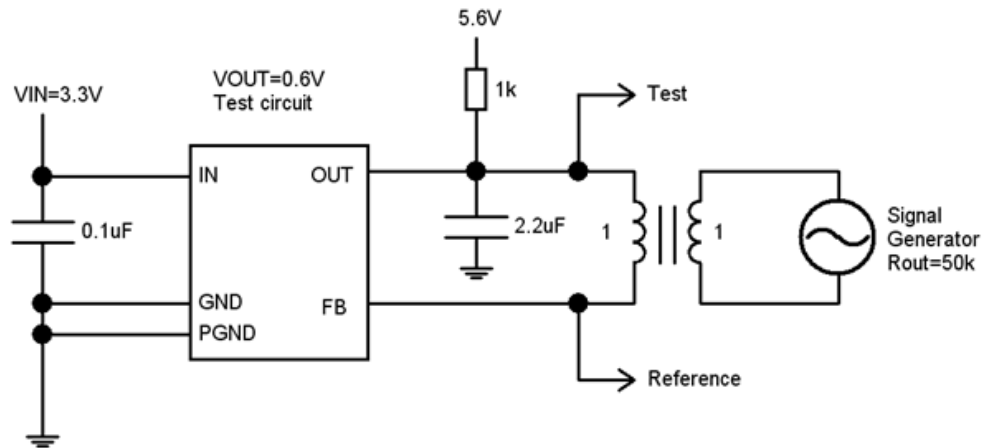

Figure 2. Test Circuits for Gain and Phase Plots

Application Information

The following show some typical application examples for the ZXRE160.



Figure 3. 15V Supply Monitor

In shunt regulator mode it is necessary to include the compensation capacitor C2 to guarantee stability. C2 may range in value from 0.1µF to 10µF depending on the application. The minimum value of C2 can be determined from the following equation (resistor values are in kΩ):

$$C2_{MIN} \geq \frac{R_2}{R_3(R_1 + R_2)} \mu F$$

Both C1 and C2 should be as close to the ZXRE160 as possible and connected to it with the shortest possible track. In the case of Figure 10 and Figure 11, it means the opto-coupler will have to be carefully positioned to enable this.



$$V_{OUT} = V_{REF}$$

$$R_3 = \frac{V_{IN} - V_{OUT}}{I_{R3}}$$

Figure 4. 0.6V Shunt Regulator

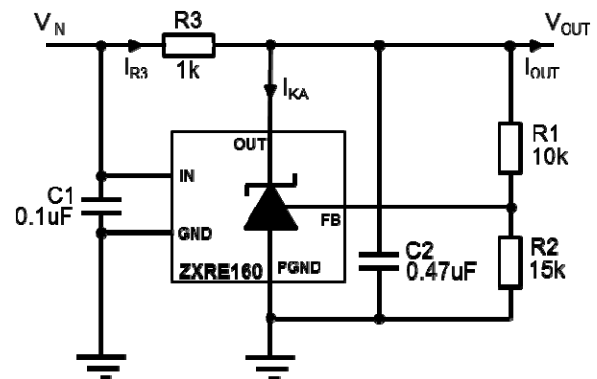

$$V_{OUT} = V_{REF} \left(1 + \frac{R_1}{R_2} \right)$$

$$R_3 = \frac{V_{IN} - V_{OUT}}{I_{R3}}$$

Figure 5. 1.0V Shunt Regulator

Application Information (cont.)

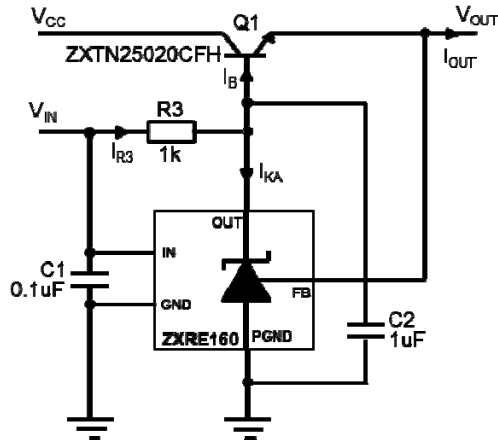

$$V_{OUT} = V_{REF}$$

Figure 6. 0.6V Series LDO Regulator

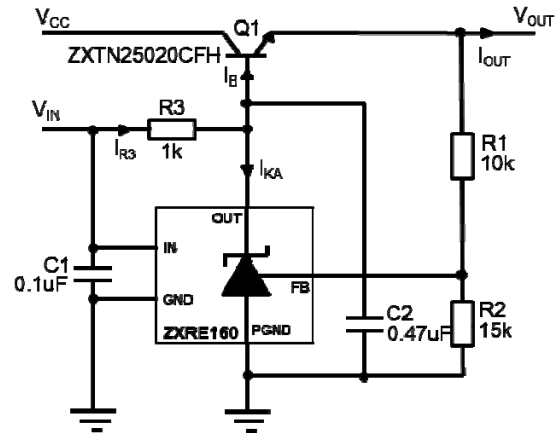

$$V_{OUT} = V_{REF} \left(1 + \frac{R1}{R2} \right)$$

Figure 7. 1.0V Series LDO Regulator

Design guide:

1. Determine I_{OUT} and choose a suitable transistor taking power dissipation into consideration.
2. Determine I_B from $I_B = \frac{I_{OUT(max)}}{(h_{FE(min)} + 1)}$
3. Determine I_{R3} from $I_{R3} \geq I_B + I_{KA(min)}$. The design of the ZXRE160 effectively means there is no $I_{KA(min)}$ limitation as in conventional references. There is only an output leakage current which is a maximum of $1\mu A$. Nevertheless, it is necessary to determine an $I_{KA(min)}$ to ensure that the device operates within its linear range at all times. $I_{KA(min)} \geq 10\mu A$ should be adequate for this.
4. Determine $R3$ from $R3 = \frac{V_{IN} - (V_{OUT} + V_{BE})}{I_{R3}}$.

Although unlikely to be a problem, ensure that $I_{R3} \leq 15$ mA.

Application Information (cont.)

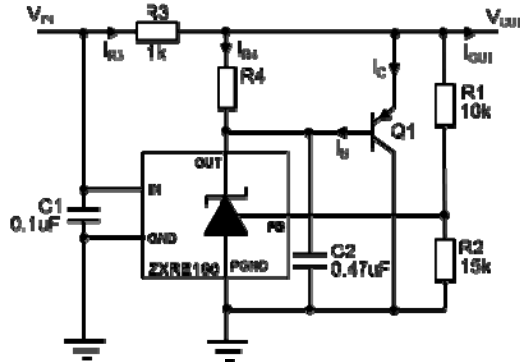

$$V_{OUT} = V_{REF} \left(1 + \frac{R1}{R2} \right)$$

$$V_{OUT} \geq 0.2V + V_{BE}$$

$$R3 = \frac{V_{IN} - V_{OUT}}{I_{R3}}$$

Figure 8. 1V Current-Boosted Shunt Regulator

Design guide

1. Determine I_{OUT} and choose a suitable transistor taking power dissipation into consideration.
2. Determine I_B from $I_B = \frac{I_{OUT(max)}}{(h_{FE(min)} + 1)}$
3. Determine I_{R3} from $I_{R3} = I_{OUT(max)}$
4. Determine $R3$ from $R3 = \frac{V_{IN} - V_{OUT}}{I_{R3}}$
5. It is best to let the ZXRE160 supply as much current as it can before bringing Q1 into conduction. Not only does this minimize the strain on Q1, it also guarantees the most stable operation. Choose a nominal value between 10mA and <15mA for this current, I_{R4} .

Calculate $R4$ from $R4 = \frac{V_{BE}}{I_{R4}}$

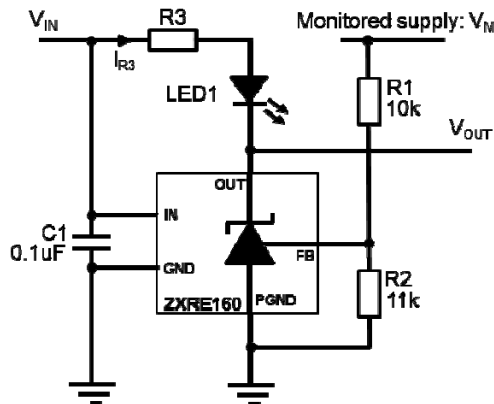

V_{OUT} goes low and LED is lit when monitored supply

$$V_M > V_{REF} \left(1 + \frac{R1}{R2} \right)$$

$$R3 = \frac{V_{IN} - (V_F + 0.2)}{I_{R3}}$$

$$15mA \geq I_{R3} \leq I_F(MAX)$$

V_F and I_F are forward voltage drop and current of LED1.

Figure 9. 1.15V Over-Voltage Indicator

Application Information (cont.)

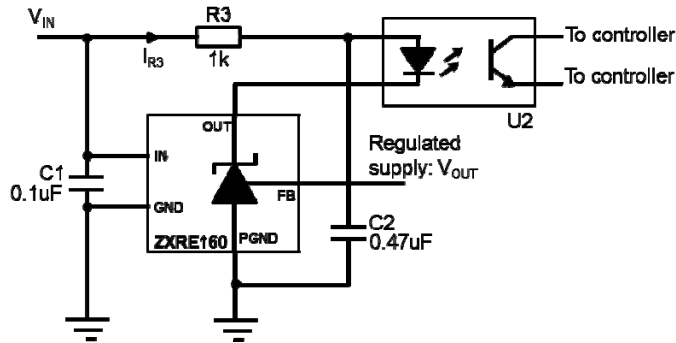

$$V_{OUT} = V_{REF}$$

$$R3 = \frac{V_{IN} - (V_F + 0.2)}{I_{R3}}$$

$$15\text{mA} \geq I_{R3} \leq I_{F(\text{MAX})}$$

Figure 10. Opto-Isolated 0.6V Shunt Regulator



$$V_{OUT} = V_{REF} \left(1 + \frac{R1}{R2} \right)$$

$$R3 = \frac{V_{IN} - (V_F + 0.2)}{I_{R3}}$$

$$15\text{mA} \geq I_{R3} \leq I_{F(\text{MAX})}$$

Figure 11. Opto-Isolated 1.0V Shunt Regulator

V_F and I_F are forward voltage drop and forward current respectively for the optocoupler LED

More applications information is available in the following publications which can be found on Diodes' web site.

- AN58 - Designing with Diodes' References – *Shunt Regulation*
- AN59 - Designing with Diodes' References – *Series Regulation*
- AN60 - Designing with Diodes' References – *Fixed Regulators and Opto-Isolation*
- AN61 - Designing with Diodes' References – *Extending the operating voltage range*
- AN62 - Designing with Diodes' References – *Other Applications*
- AN63 - Designing with Diodes' References – *ZXRE060 Low Voltage Regulator*



Ordering Information



Tol.	Part Number	Package	Identification Code	Reel Size	Tape Width	Quantity/Reel
0.5%	ZXRE160AET5TA	TSOT25	R8	7", 180mm	8mm	3000
	ZXRE160AH5TA	SC70/SOT353	R9	7", 180mm	8mm	3000
	ZXRE160AFT4-7	DFN1520H4-6	R8	7", 180mm	8mm	3000
1%	ZXRE160ET5TA	TSOT25	Z8	7", 180mm	8mm	3000
	ZXRE160H5TA	SC70/SOT353	Z9	7", 180mm	8mm	3000
	ZXRE160FT4-7	X2-DFN1520-6	Z8	7", 180mm	8mm	3000

Marking Information

1. TSOT25, SC70/SOT353

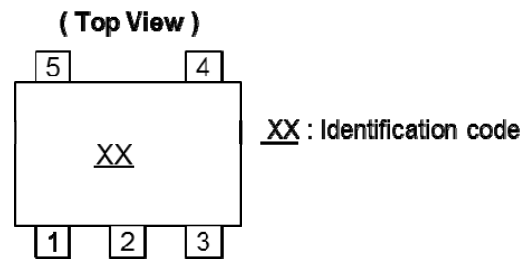

2. X2-DFN1520-6

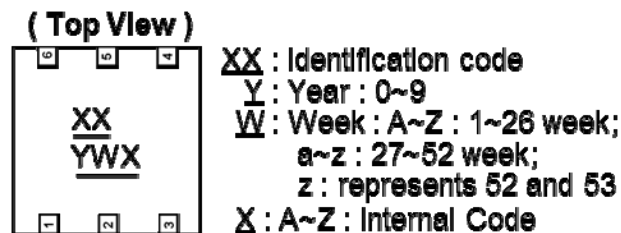

Package Outline Dimensions (All dimensions in mm.)

TSOT25

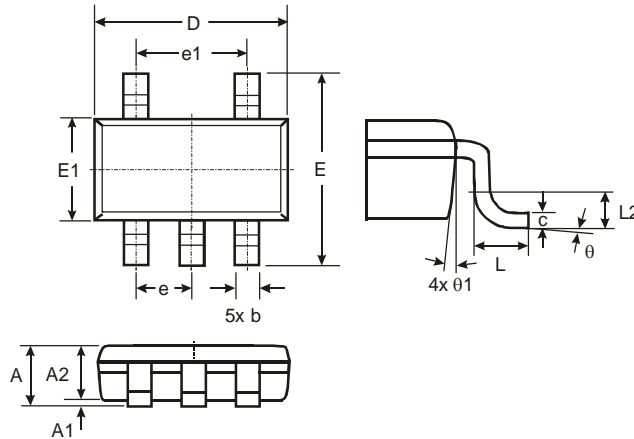

TSOT25			
Dim	Min	Max	Typ
A	-	1.00	-
A1	0.01	0.10	-
A2	0.84	0.90	-
D	-	-	2.90
E	-	-	2.80
E1	-	-	1.60
b	0.30	0.45	-
c	0.12	0.20	-
e	-	-	0.95
e1	-	-	1.90
L	0.30	0.50	-
L2	-	-	0.25
theta	0°	8°	4°
theta1	4°	12°	-
All Dimensions in mm			

SC70/SOT353

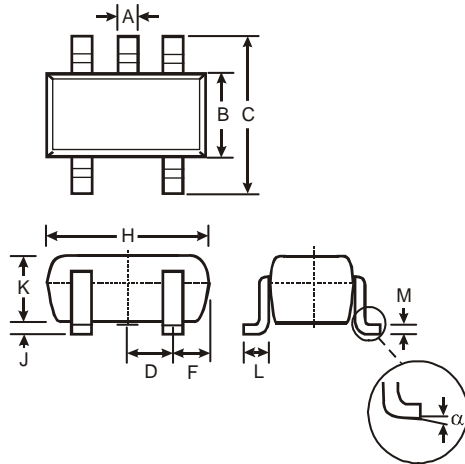

SOT353		
Dim	Min	Max
A	0.10	0.30
B	1.15	1.35
C	2.00	2.20
D	0.65 Typ	
F	0.40	0.45
H	1.80	2.20
J	0	0.10
K	0.90	1.00
L	0.25	0.40
M	0.10	0.22
alpha	0°	8°
All Dimensions in mm		

X2-DFN1520-6



X2-DFN1520-6			
Dim	Min	Max	Typ
A	-	0.40	-
A1	0	0.05	-
A3	-	-	0.13
b	0.20	0.30	-
D	1.45	1.575	-
D2	1.00	1.20	-
e	-	-	0.50
E	1.95	2.075	-
E2	0.70	0.90	-
L	0.25	0.35	-
All Dimensions in mm			

Suggested Pad Layout

TSOT25

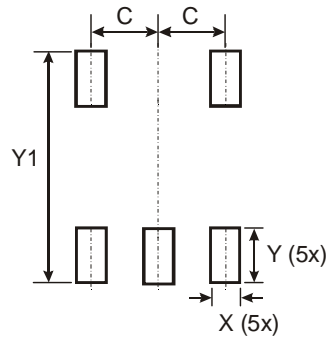

Dimensions	Value (in mm)
C	0.950
X	0.700
Y	1.000
Y1	3.199

SC70/SOT353



Dimensions	Value (in mm)
Z	2.5
G	1.3
X	0.42
Y	0.6
C1	1.9
C2	0.65

X2-DFN1520-6

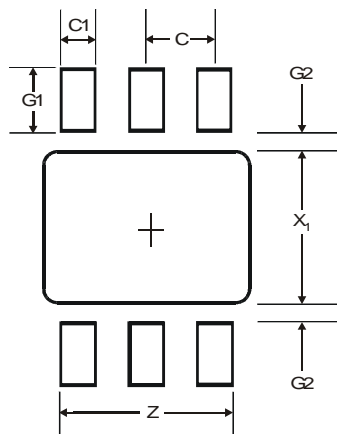

Dimensions	Value (in mm)
Z	1.25
G1	0.45
G2	0.15
X1	1.10
C	0.50
C1	0.25

IMPORTANT NOTICE

DIODES INCORPORATED MAKES NO WARRANTY OF ANY KIND, EXPRESS OR IMPLIED, WITH REGARDS TO THIS DOCUMENT, INCLUDING, BUT NOT LIMITED TO, THE IMPLIED WARRANTIES OF MERCHANTABILITY AND FITNESS FOR A PARTICULAR PURPOSE (AND THEIR EQUIVALENTS UNDER THE LAWS OF ANY JURISDICTION).

Diodes Incorporated and its subsidiaries reserve the right to make modifications, enhancements, improvements, corrections or other changes without further notice to this document and any product described herein. Diodes Incorporated does not assume any liability arising out of the application or use of this document or any product described herein; neither does Diodes Incorporated convey any license under its patent or trademark rights, nor the rights of others. Any Customer or user of this document or products described herein in such applications shall assume all risks of such use and will agree to hold Diodes Incorporated and all the companies whose products are represented on Diodes Incorporated website, harmless against all damages.

Diodes Incorporated does not warrant or accept any liability whatsoever in respect of any products purchased through unauthorized sales channel. Should Customers purchase or use Diodes Incorporated products for any unintended or unauthorized application, Customers shall indemnify and hold Diodes Incorporated and its representatives harmless against all claims, damages, expenses, and attorney fees arising out of, directly or indirectly, any claim of personal injury or death associated with such unintended or unauthorized application.

Products described herein may be covered by one or more United States, international or foreign patents pending. Product names and markings noted herein may also be covered by one or more United States, international or foreign trademarks.

LIFE SUPPORT

Diodes Incorporated products are specifically not authorized for use as critical components in life support devices or systems without the express written approval of the Chief Executive Officer of Diodes Incorporated. As used herein:

A. Life support devices or systems are devices or systems which:

1. are intended to implant into the body, or
2. support or sustain life and whose failure to perform when properly used in accordance with instructions for use provided in the labeling can be reasonably expected to result in significant injury to the user.

B. A critical component is any component in a life support device or system whose failure to perform can be reasonably expected to cause the failure of the life support device or to affect its safety or effectiveness.

Customers represent that they have all necessary expertise in the safety and regulatory ramifications of their life support devices or systems, and acknowledge and agree that they are solely responsible for all legal, regulatory and safety-related requirements concerning their products and any use of Diodes Incorporated products in such safety-critical, life support devices or systems, notwithstanding any devices- or systems-related information or support that may be provided by Diodes Incorporated. Further, Customers must fully indemnify Diodes Incorporated and its representatives against any damages arising out of the use of Diodes Incorporated products in such safety-critical, life support devices or systems.

Copyright © 2012, Diodes Incorporated

www.diodes.com

Данный компонент на территории Российской Федерации

Вы можете приобрести в компании MosChip.

Для оперативного оформления запроса Вам необходимо перейти по данной ссылке:

<http://moschip.ru/get-element>

Вы можете разместить у нас заказ для любого Вашего проекта, будь то серийное производство или разработка единичного прибора.

В нашем ассортименте представлены ведущие мировые производители активных и пассивных электронных компонентов.

Нашей специализацией является поставка электронной компонентной базы двойного назначения, продукции таких производителей как XILINX, Intel (ex.ALTERA), Vicor, Microchip, Texas Instruments, Analog Devices, Mini-Circuits, Amphenol, Glenair.

Сотрудничество с глобальными дистрибьюторами электронных компонентов, предоставляет возможность заказывать и получать с международных складов практически любой перечень компонентов в оптимальные для Вас сроки.

На всех этапах разработки и производства наши партнеры могут получить квалифицированную поддержку опытных инженеров.

Система менеджмента качества компании отвечает требованиям в соответствии с ГОСТ Р ИСО 9001, ГОСТ РВ 0015-002 и ЭС РД 009

Офис по работе с юридическими лицами:

105318, г.Москва, ул.Щербаковская д.3, офис 1107, 1118, ДЦ «Щербаковский»

Телефон: +7 495 668-12-70 (многоканальный)

Факс: +7 495 668-12-70 (доб.304)

E-mail: info@moschip.ru

Skype отдела продаж:

moschip.ru

moschip.ru_4

moschip.ru_6

moschip.ru_9