



KSZ8091RNA/KSZ8091RND

10Base-T/100Base-TX Physical Layer Transceiver

Description

The KSZ8091RNA is a single-supply 10Base-T/100Base-TX Ethernet physical-layer transceiver for transmission and reception of data over standard CAT-5 unshielded twisted pair (UTP) cable.

The KSZ8091RNA is a highly-integrated PHY solution. It reduces board cost and simplifies board layout by using on-chip termination resistors for the differential pairs and by integrating a low-noise regulator to supply the 1.2V core, and by offering a flexible 1.8/2.5/3.3V digital I/O interface.

The KSZ8091RNA offers the Reduced Media Independent Interface (RMII) for direct connection with RMII-compliant Ethernet MAC processors and switches.

As the power-up default, the KSZ8091RNA uses a 25MHz crystal to generate all required clocks, including the 50MHz RMII reference clock output for the MAC. The KSZ8091RND takes in the 50MHz RMII reference clock as the power-up default.

Energy Efficient Ethernet (EEE) provides further power saving during idle traffic periods and Wake-on-LAN (WOL) provides a mechanism for the KSZ8091RNA to wake up a system that is in standby power mode.

The KSZ8091RNA and KSZ8091RND are available in 24-pin, lead-free QFN packages.

Applications

- Game console
- IP phone
- IP set-top box
- IP TV
- LOM
- Printer

For more information, contact your local Micrel sales representative, or visit Micrel at:

www.micrel.com

Micrel Inc., is a leading global manufacturer of IC solutions for the worldwide analog, Ethernet and high bandwidth markets. The Company's products include advanced mixed-signal, analog and power semiconductors; high performance communication, clock management, Ethernet switch and physical layer transceiver ICs. Company customers include leading manufacturers of enterprise, consumer, industrial, mobile, telecommunications, automotive, and computer products. Corporation headquarters and state-of-the-art wafer fabrication facilities are located in San Jose, CA with regional sales and support offices and advanced technology design centers situated throughout the Americas, Europe and Asia. In addition, the Company maintains an extensive network of distributors and reps worldwide.

www.micrel.com

Functional Diagram

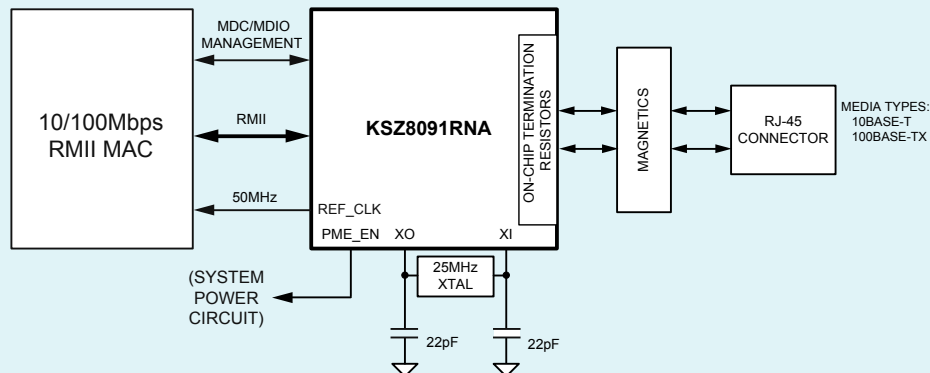

KSZ8091RNA/KSZ8091RND - 10Base-T/100Base-TX PHYSICAL LAYER TRANSCEIVER

Key Features	Benefits
Single-chip 10Base-T/100Base-TX IEEE 802.3-compliant Ethernet transceiver	Standard compliance ensures that the device will work with other standard-compliant, already deployed devices
RMII v1.2 Interface support, with a 50MHz reference clock output to MAC and an option to input a 50MHz reference clock	Provides flexible options for the 50MHz RMII reference clock as the input or output
RMII back-to-back mode support	Allows creation of low-cost 100Mbps copper repeater using only two KSZ8091 PHYs
MDC/MDIO management interface	Allows the MAC processor complete access to the KSZ8091 control and status registers
On-chip termination resistors for the differential pairs	On-chip termination (eliminating four external resistors) simplifies PCB design, reduces system BOM, and improves overall signal integrity and EMI emission
On-chip regulator	Reduces BOM cost by eliminating external regulator for 1.2V core
HP Auto MDI/MDI-X to reliably detect and correct straight-through and crossover cable connections with disable and enable option	Easy-to-use feature eliminates the need for crossover cable, which reduces installation costs
Energy Efficient Ethernet (EEE) support with low-power idle (LPI) mode for 100Base-TX and transmit amplitude reduction with 10Base-Te option	Saves greater than 50% power in idle mode
Wake-on-LAN (WOL) support with either magic packet, link status change, or robust custom-packet detection	Provides a mechanism to wake up a system that is in standby power mode, saving total system power consumption
Multiple loopback options	Allows diagnostic testing for RMII and line side data paths
Single 3.3V power supply with VDD I/O options for 1.8V, 2.5V, or 3.3V	Enables low-power and flexible I/O design
Power-down and power-saving modes	Optimizes power consumption based on the status of the link or the device
LinkMD TDR-based cable diagnostics	Identifies common cable faults in production testing and in deployment

Contact Micrel, Inc.

Location	Address		Telephone	Fax
Corporate HQ	2180 Fortune Drive	San Jose, CA 95131 USA	+1 408 944 0800	+1 408 944 0970
Western USA	2180 Fortune Drive	San Jose, CA 95131 USA	+1 408 944 0800	+1 408 944 0970
Central USA	2425 N. Central Express Way, Suite 351	Richardson, TX 75080 USA	+1 972 393 2533	+1 972 393 2370
Eastern USA	93 Branch Street	Medford, NJ 08055 USA	+1 609 654 0078	+1 609 654 0989
Latin America	2425 N. Central Express Way, Suite 351	Richardson, TX 75080 USA	+1 972 393 2533	+1 972 393 2370
Hong Kong	Unit 213-215, Photonics Centre, #2 Science Park East Ave., Hong Kong Science Park	Shatin, N.T., Hong Kong	+852 2886 8839	+852 2886 8851
China	No. 2001 & 2002, 20/F, Excellence Times Plaza, 4068 Yitian Road, Futian Dist	Shenzhen, P.R. China 518048	+86 755 8302 7618	+86 755 8302 7637
Japan	2-3-1 Minato Morai Queen's Tower A 14F, Nishi-ku, Yokohama	Kanagawa 220-6014, Japan	+81 45 224 6616	+81 45 224 6716
Korea	42nd Flr, Korean Academy of Science and Tech Bldg, 7-1 Gumi-dong Bundang-gu	Gyeonggi, 463-808, Korea	+82 2 538 2380	+82 2 538 2381
Singapore/India	7500A Beach Road, #07-324 The Plaza	Singapore 199591	+65 6291 1318	+65 6291 1332
Taiwan	4F, No. 43 Lane 188, Rueiguang Road, Nei-Hu District	Taipei 11491 Taiwan, R.O.C	+886 2 8751 0600	+886 2 8751 0746
UK/EMEA	1st Floor, 3 Lockside Place, Mill Lane, Newbury, Berks	United Kingdom RG14 5QS	+44 1635 524455	+44 1635 524466
France/Southern Europe	Les Laurentides - Batiment Ontario, 3 Avenue du Quebec	91140 Villebon sur Yvette, France	+33 0 1 6092 4190	+33 0 1 6092 4189



1.800.944.0800 Tel
1.408.474.1000 Fax
www.micrel.com

Mouser Electronics

Authorized Distributor

Click to View Pricing, Inventory, Delivery & Lifecycle Information:

[Micrel:](#)

[KSZ8091RNDIA TR](#) [KSZ8091RNDIA-TR](#)

Данный компонент на территории Российской Федерации

Вы можете приобрести в компании MosChip.

Для оперативного оформления запроса Вам необходимо перейти по данной ссылке:

<http://moschip.ru/get-element>

Вы можете разместить у нас заказ для любого Вашего проекта, будь то серийное производство или разработка единичного прибора.

В нашем ассортименте представлены ведущие мировые производители активных и пассивных электронных компонентов.

Нашей специализацией является поставка электронной компонентной базы двойного назначения, продукции таких производителей как XILINX, Intel (ex.ALTERA), Vicor, Microchip, Texas Instruments, Analog Devices, Mini-Circuits, Amphenol, Glenair.

Сотрудничество с глобальными дистрибьюторами электронных компонентов, предоставляет возможность заказывать и получать с международных складов практически любой перечень компонентов в оптимальные для Вас сроки.

На всех этапах разработки и производства наши партнеры могут получить квалифицированную поддержку опытных инженеров.

Система менеджмента качества компании отвечает требованиям в соответствии с ГОСТ Р ИСО 9001, ГОСТ РВ 0015-002 и ЭС РД 009

Офис по работе с юридическими лицами:

105318, г.Москва, ул.Щербаковская д.3, офис 1107, 1118, ДЦ «Щербаковский»

Телефон: +7 495 668-12-70 (многоканальный)

Факс: +7 495 668-12-70 (доб.304)

E-mail: info@moschip.ru

Skype отдела продаж:

moschip.ru

moschip.ru_4

moschip.ru_6

moschip.ru_9