Input

- + 5 DC voltage
- Optical input (optional C-mount for lens)
- Mechanical potentiometer for APD-bias setting

Output

- 16 channels voltage signal of amplified APD (300 MHz bandwidth and additional gain of 2200)
- Monitor output of APD bias setting
- Temperature information

Features

- 16 element APD array
- 100 MHz bandwidth
- 2.2 k Ω transimpedance
- Low noise

Description

Compact evaluation board for APD array including high bandwidth, amplification and temperature compensated power control.

Application

- LIDAR applications
- Shape recognition
- Collision warning

RoHS

2002/95/EC

Absolute maximum ratings

Symbol	Parameter	Min	Max	Unit
T _{STG}	Storage temp	-40	125	°C
T _{OP}	Operating temp	-25	70	°C
M _{max}	Overall gain		220 k	

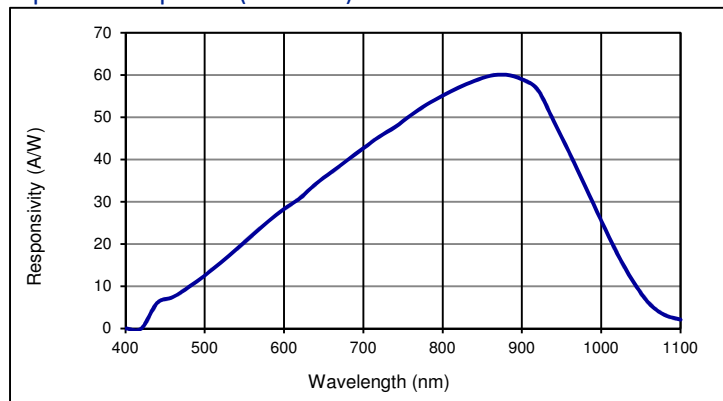
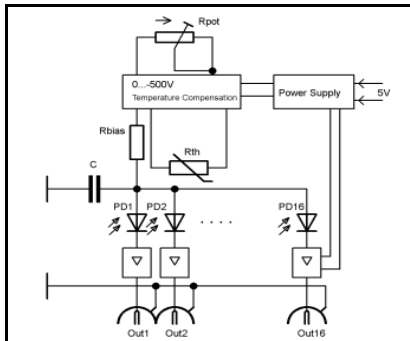
Spectral response (M = 100)

Schematic

Electro-optical characteristics of APD chip @ 23 °C

Symbol	Characteristic	Test Condition	Min	Typ	Max	Unit
	No of elements		16*			
	Active area		1000 x 405*			μm
	Gap; Pitch		95 ; 500*			μm
I _D	Dark current	M = 50; per element		2.0		nA
C	Capacitance	M = 50, per element		1.0		pF
	Responsivity	M = 100; $\lambda = 905 \text{ nm}$	55	60		A/W
t _R	Rise time	M = 100; $\lambda = 905 \text{ nm}$; R _L = 50 Ω		2		ns
V _{BR}	Breakdown voltage	I _R = 2 μA	100	300	400	V
	Temperature coefficient			1.45		V/K
	Cross talk	$\lambda = 905 \text{ nm}$		50		dB
	Photo current uniformity	M = 50		± 5	± 20	%
	Dark current uniformity	M = 50		± 5	± 20	%

* also available with 8 channel APD array and smaller pitch 16 channel APD array

European, International Sales:

First Sensor AG
 Peter-Behrens-Strasse 15
 12459 Berlin
 Germany
 T +49 30 6399 2399
 F +49 30 639923-752
 sales.opto@first-sensor.com

USA:

First Sensor Inc.
 5700 Corsa Avenue #105
 Westlake Village
 CA 91362 USA
 T +1 818 706 3400
 F +1 818 889 7053
 sales.us@first-sensor.com

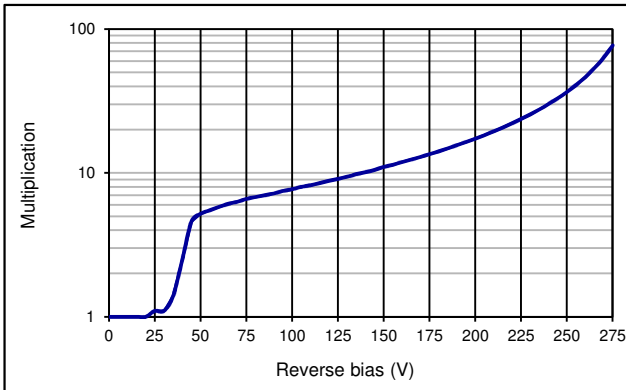
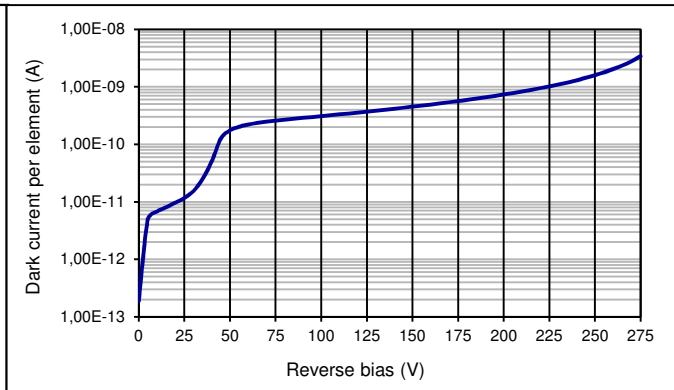
APD multiplication as fct of reverse bias (23 °C)

APD Dark current as fct of reverse bias (23 °C)

Characteristics of evaluation board @ 23 °C

Part	Characteristic	Test Condition	Min	Typ	Max	Unit
Measurement characteristics						
Amplifier	Photoelectric sensitivity incl. APD	M = 25; λ = 905 nm; 10 kHz		3.3x10 ⁻⁴ *		V/W
Amplifier	Noise equivalent power	M = 25; λ = 905 nm; 10 kHz		6x10 ⁻¹⁵ *		W/Hz ^{1/2}
Amplifier	Feedback resistance			2.2		kΩ
Amplifier	Rise time	1 Volt Step		3.5		ns
Amplifier	Bandwidth (Cut-off frequency)	-3db		300		MHz
Amplifier	Coupling			AC		
Amplifier	Output impedance			50		Ω
Amplifier	Output voltage	50Ω load			2.0	V
Amplifier	Voltage noise	1 MHz			tdb	nV/√Hz
Amplifier	Current noise	1 MHz			tbd	pV/√Hz
Power Supply (internal)						
Power Sup.	Bias range for APD (user adjustable)	DC	100	300	400	V
Power Sup.	Supply current for APD			200		mA
Power Sup.	Temperature compensated APD bias			yes		
Power Sup.	Gain stability	25 °C ± 10 °C; M = 25		± 5		%
Connector (Power supply and Signal)						
Connector	Maker: Samtec (www.samtec.com)	Type	MMCX-J-P-H-RA-TH1			
		Number	2 x 8			
		Mating cable	MMCX on BNC			
Module	Supply voltage			5		V
Module	Supply current			200		mA
Mechanical characteristics						
Module	Dimensional outline - width			30		mm
Module	Dimensional outline - length			55		mm
Module	Dimensional outline - height			55		mm
Module	Weight without optical interface			100		g
Module	Housing material			no housing		
Module	Optical interface	optional		C-Mount		
Module	Field of view of removable optics plate	with C-mount adaptor		±12		°
		without C-mount adaptor		±18		°

European, International Sales:

 First Sensor AG
 Peter-Behrens-Strasse 15
 12459 Berlin
 Germany
 T +49 30 6399 2399
 F +49 30 639923-752
 sales.opto@first-sensor.com

USA:

 First Sensor Inc.
 5700 Corso Avenue #105
 Westlake Village
 CA 91362 USA
 T +1 818 706 3400
 F +1 818 889 7053
 sales.us@first-sensor.com

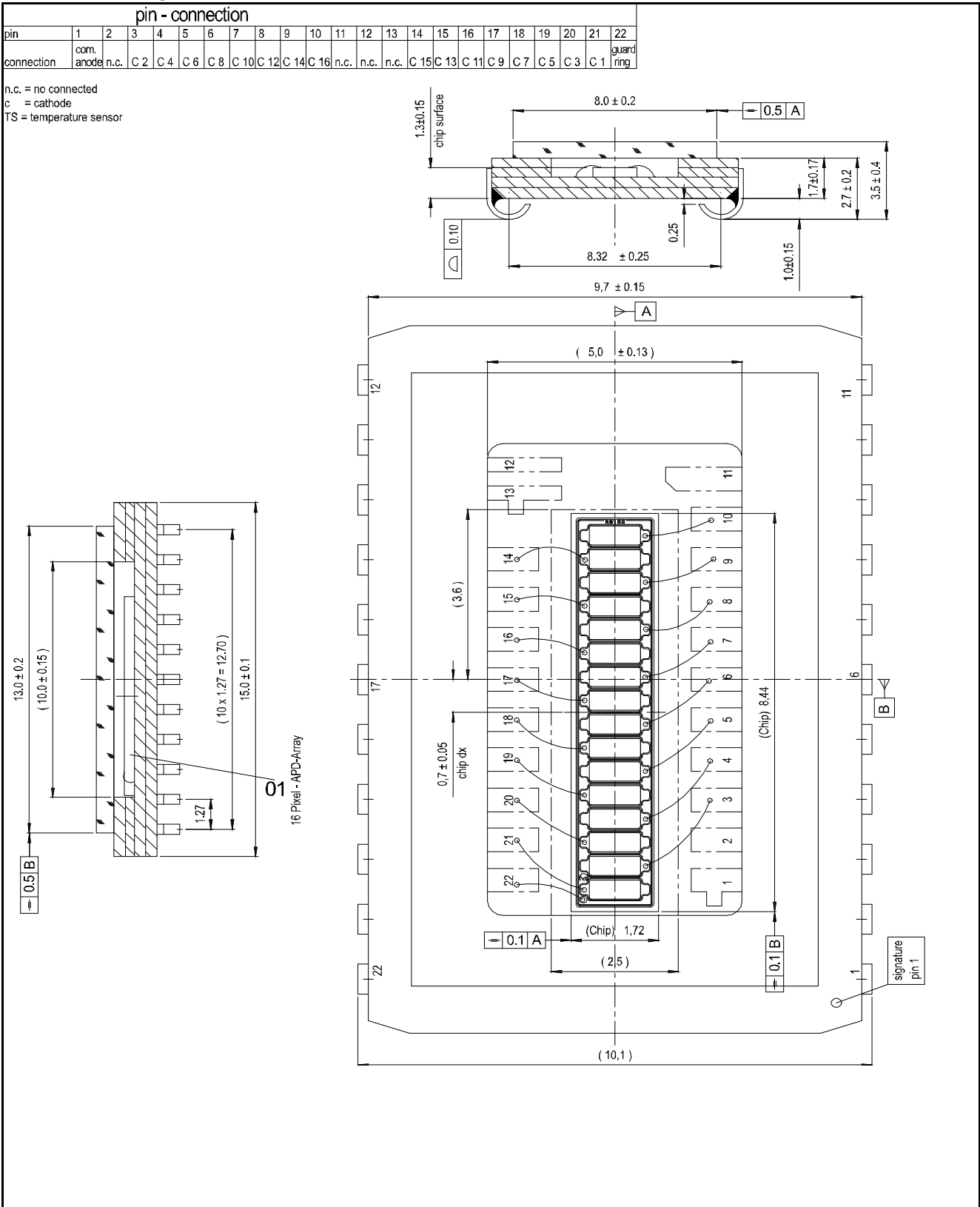
Technical Drawing APD (16AA0.4-9 SMD)

European, International Sales:

First Sensor AG
 Peter-Behrens-Strasse 15
 12459 Berlin
 Germany
 T +49 30 6399 2399
 F +49 30 639923-752
 sales.opto@first-sensor.com

USA:

First Sensor Inc.
 5700 Corsa Avenue #105
 Westlake Village
 CA 91362 USA
 T +1 818 706 3400
 F +1 818 889 7053
 sales.us@first-sensor.com

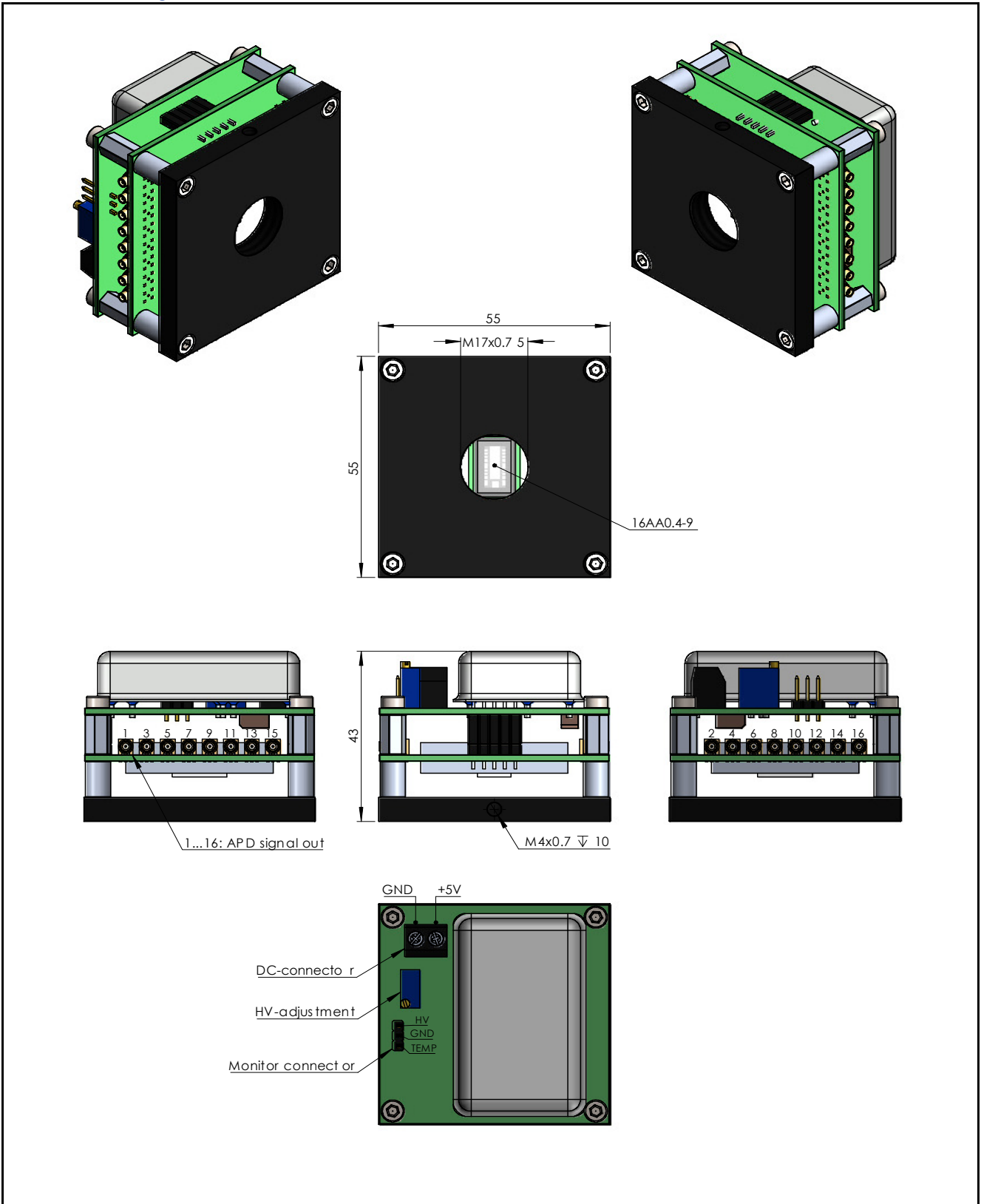
Technical Drawing Module



European, International Sales:



First Sensor AG
 Peter-Behrens-Strasse 15
 12459 Berlin
 Germany
 T +49 30 6399 2399
 F +49 30 639923-752
 sales.opto@first-sensor.com

USA:



First Sensor Inc.
 5700 Corsa Avenue #105
 Westlake Village
 CA 91362 USA
 T +1 818 706 3400
 F +1 818 889 7053
 sales.us@first-sensor.com

Connector schedule

Connectors			
PIN	Signal connectors	PIN	DC connector
1	μBNC APD channel 1	+5V	+5V supply voltage
2	μBNC APD channel 2	GND	supply voltage ground
3	μBNC APD channel 3		
4	μBNC APD channel 4	PIN	Monitor connectors
5	μBNC APD channel 5	HV	APD bias monitor (1:200)
6	μBNC APD channel 6	GND	Ground for monitors
7	μBNC APD channel 7	TEMP	LM20 temperature signal
8	μBNC APD channel 8		
9	μBNC APD channel 9		
10	μBNC APD channel 10		
11	μBNC APD channel 11		
12	μBNC APD channel 12		
13	μBNC APD channel 13		
14	μBNC APD channel 14		
15	μBNC APD channel 15		
16	μBNC APD channel 16		

Schematic

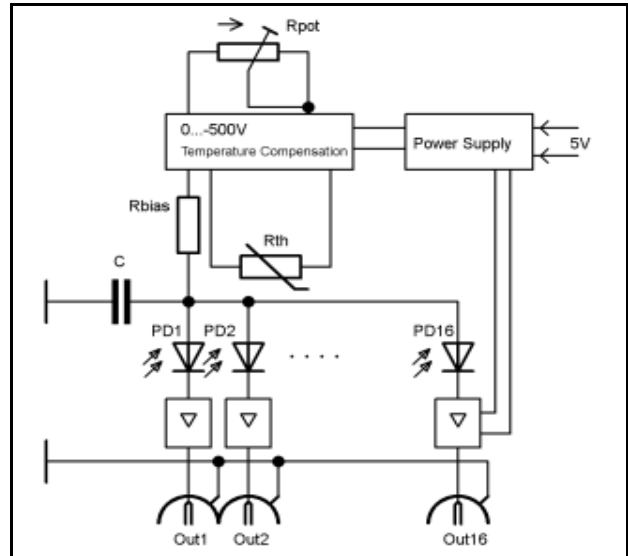

Characteristic curve of LM20 temp sensor

T [°C]	Voltage [V]	T [°C]	Voltage [V]	T [°C]	Voltage [V]
-40	2,317692	14	1,7021395	68	1,0639589
-38	2,2952973	16	1,6789067	70	1,039888
-36	2,2728715	18	1,6556429	72	1,0157861
-34	2,2504147	20	1,632348	74	0,9916531
-32	2,2279269	22	1,6090221	76	0,9674891
-30	2,205408	24	1,5856651	78	0,9432941
-28	2,1828581	26	1,5622771	80	0,919068
-26	2,1602771	28	1,5388581	82	0,8948109
-24	2,1376651	30	1,515408	84	0,8705227
-22	2,1150221	32	1,4919269	86	0,8462035
-20	2,092348	34	1,4684147	88	0,8218533
-18	2,0696429	36	1,4448715	90	0,797472
-16	2,0469067	38	1,4212973	92	0,7730597
-14	2,0241395	40	1,397692	94	0,7486163
-12	2,0013413	42	1,3740557	96	0,7241419
-10	1,978512	44	1,3503883	98	0,6996365
-8	1,9556517	46	1,3266899	100	0,6751
-6	1,9327603	48	1,3029605	102	0,6505325
-4	1,9098379	50	1,2792	104	0,6259339
-2	1,8868845	52	1,2554085	106	0,6013043
0	1,8639	54	1,2315859	108	0,5766437
2	1,8408845	56	1,2077323	110	0,551952
4	1,8178379	58	1,1838477	112	0,5272293
6	1,7947603	60	1,159932	114	0,5024755
8	1,7716517	62	1,1359853	116	0,4776907
10	1,748512	64	1,1120075	118	0,4528749
12	1,7253413	66	1,0879987	120	0,428028

Characteristic curve of LM20 temp sensor

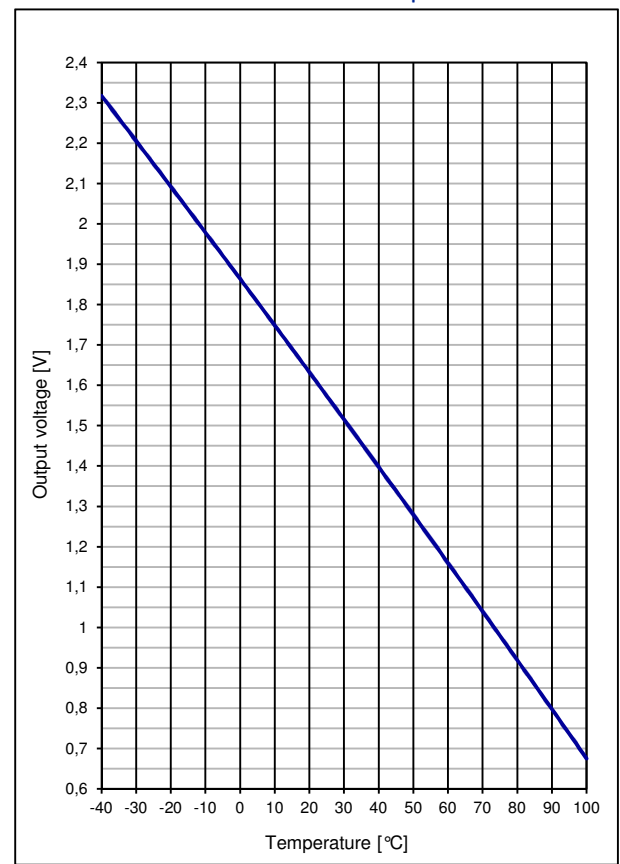

Handling: Please consider ESD protection while handling.

Disclaimer: Due to our strive for continuous improvement, specifications are subject to change within our PCN policy according to JESD46C.

European, International Sales:



First Sensor AG
 Peter-Behrens-Strasse 15
 12459 Berlin
 Germany
 T +49 30 6399 2399
 F +49 30 639923-752
 sales.opto@first-sensor.com

USA:



First Sensor Inc.
 5700 Corsa Avenue #105
 Westlake Village
 CA 91362 USA
 T +1 818 706 3400
 F +1 818 889 7053
 sales.us@first-sensor.com

Данный компонент на территории Российской Федерации

Вы можете приобрести в компании MosChip.

Для оперативного оформления запроса Вам необходимо перейти по данной ссылке:

<http://moschip.ru/get-element>

Вы можете разместить у нас заказ для любого Вашего проекта, будь то серийное производство или разработка единичного прибора.

В нашем ассортименте представлены ведущие мировые производители активных и пассивных электронных компонентов.

Нашей специализацией является поставка электронной компонентной базы двойного назначения, продукции таких производителей как XILINX, Intel (ex.ALTERA), Vicor, Microchip, Texas Instruments, Analog Devices, Mini-Circuits, Amphenol, Glenair.

Сотрудничество с глобальными дистрибьюторами электронных компонентов, предоставляет возможность заказывать и получать с международных складов практически любой перечень компонентов в оптимальные для Вас сроки.

На всех этапах разработки и производства наши партнеры могут получить квалифицированную поддержку опытных инженеров.

Система менеджмента качества компании отвечает требованиям в соответствии с ГОСТ Р ИСО 9001, ГОСТ РВ 0015-002 и ЭС РД 009

Офис по работе с юридическими лицами:

105318, г.Москва, ул.Щербаковская д.3, офис 1107, 1118, ДЦ «Щербаковский»

Телефон: +7 495 668-12-70 (многоканальный)

Факс: +7 495 668-12-70 (доб.304)

E-mail: info@moschip.ru

Skype отдела продаж:

moschip.ru

moschip.ru_4

moschip.ru_6

moschip.ru_9