

K5V Illuminated Tact Switch



Features

- Gold plated dome contact SPST/SPDT
- Excellent ergonomics
- High bright leds
- Reduced space usage on board
- 40 N overload
- Tape and reel
- RoHS compliant and compatible

Typical Applications

- When backlighting and switch are required to be a "2 in 1" component
- The dome contact secures a superior contact reliability in time
- The ergonomics of K5V provides a long travel, a sharp tactile feel and an audible click
- Server, storage, automotive, network infrastructure, medical

Specification

FUNCTION: momentary action
 CONTACT ARRANGEMENT: Normally Open + Normally Closed
 TERMINALS:
 THT: Through hole terminals with positioning pegs
 SMT: Surface mount terminals with positioning pegs
 PM: Panel mount solder terminals with wire hole

Electrical

POWER MIN/MAX: 0.02VA / 1.0VA
 VOLTAGE MIN/MAX: 20mVdc – 32 Vdc
 CURRENT MIN/MAX: 0.1mA – 100mA
 CONTACT RESISTANCE: <150m Ω
 INSULATION RESISTANCE: >1G Ω initial, >10M Ω after damp heat
 BOUNCE TIME: <5ms

Mechanical

| Version | Operating force FA ¹ Newtons (grams) | Operating life (operations) | Travel (total travel) mm(mm) |
|--------------|---|-----------------------------------|------------------------------------|
| THT, SMT, PM | 4.0 (400) | 25,000 | 1.2 (2.4) |

¹ Tolerances of operating force FA is ± 25%.

Environmental

OPERATING TEMPERATURE: -40°C to 85°C
 STORAGE TEMPERATURE: -50°C to 85°C
 RELATIVE HUMIDITY: 90 to 96% according to NF EN 60068-2-30
 PROTECTION: dust protection and flux tight
 OVERLOAD: 40N min

Packaging

THT:
 60 pieces per tray; 1800 pieces per box
 SMT:
 330 pieces per reel (reel ø 360mm); 1320 pieces per box
 PM:
 60 pieces per tray; 2100 pieces per box

Process

SMT
 Soldering: Compatible with the lead free soldering profile
 No washing
 THT
 Soldering: Compatible with the lead free soldering profile
 No washing
 PM
 Soldering: Low wattage soldering iron (25-50 watts max).
 Solder time 3 seconds max. No washing

Materials

LEAD FREE
 CONTACTS: Au over Ni
 SOLDERING: Au over Ni
 HOUSING: Thermoplastic UL94 V0

How To Order

Our easy build-a-switch concept allows you to mix and match options to create the switch you need. To order, select desired option from each category and and place it in the appropriate box.

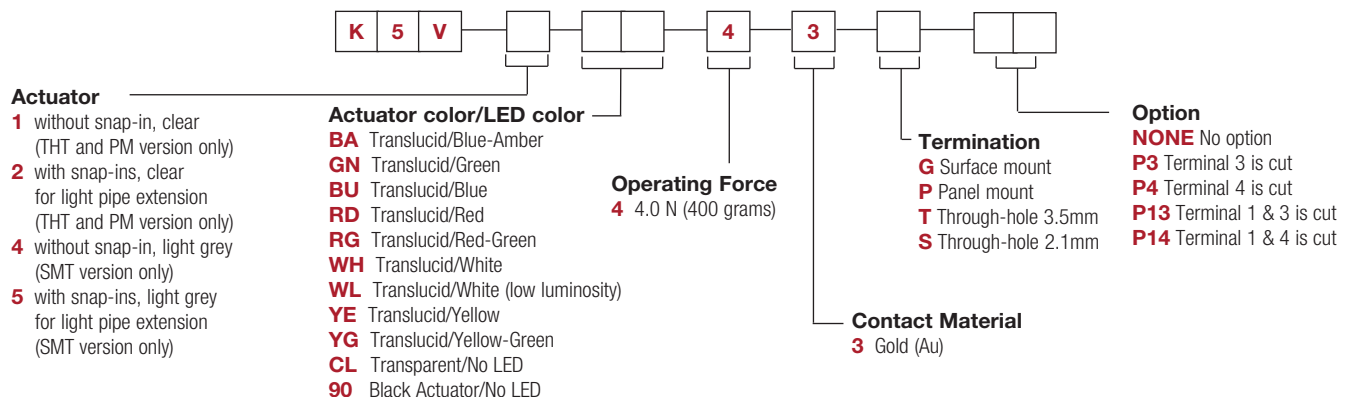

Dimensions are shown: mm
 Specifications and dimensions subject to change

K5V Illuminated Tact Switch

K5V SMT

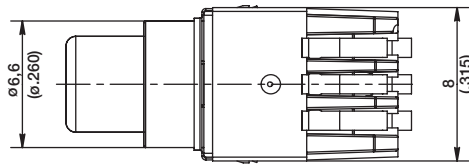
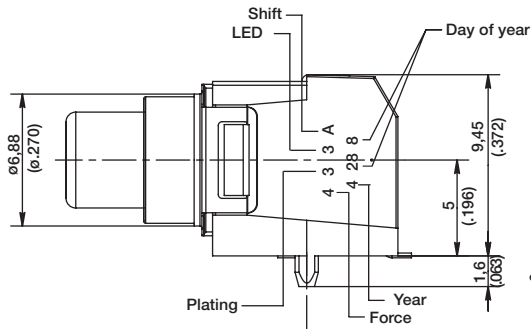
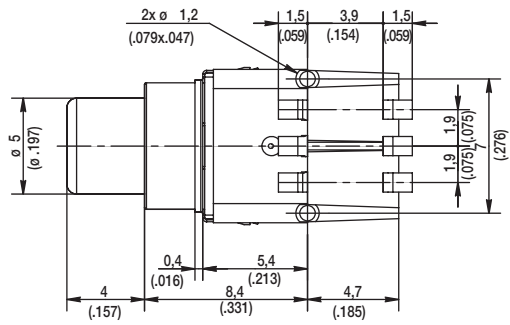

ELECTRICAL DIAGRAM

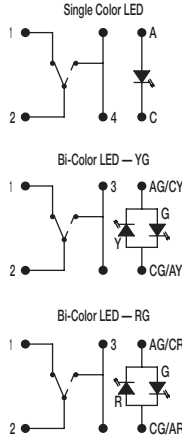

RECOMMENDED PCB LAYOUT (WITH HOLES)

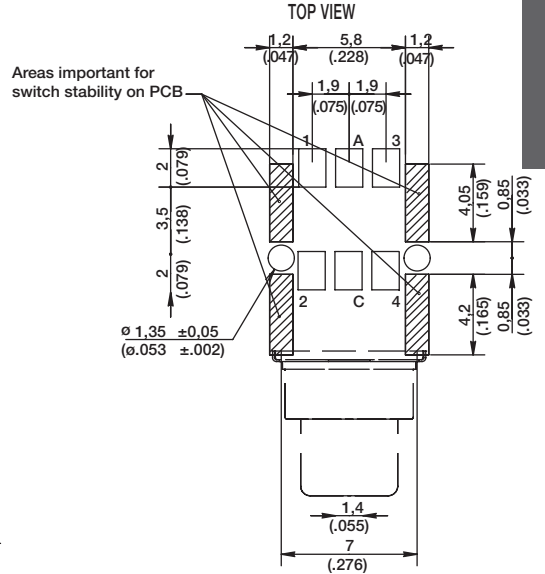

Tactile Switches

TAPE & REEL

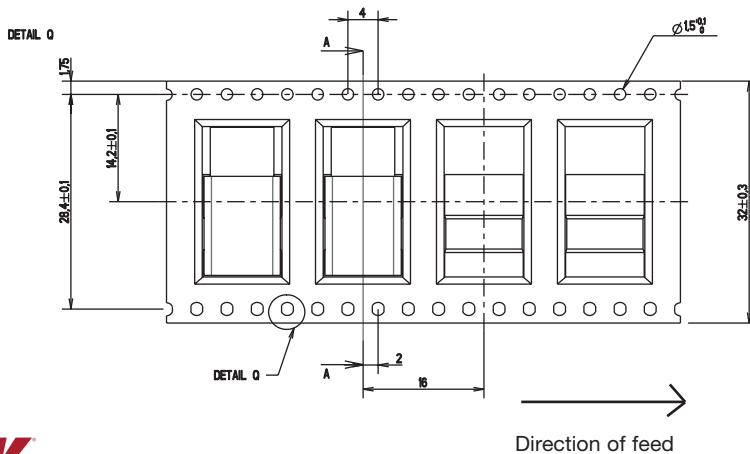
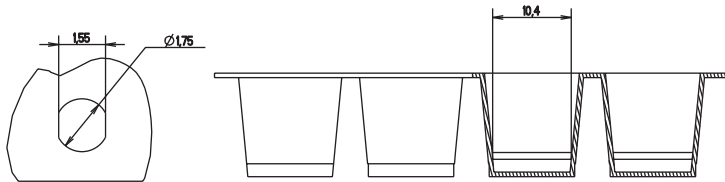

COUPE A-A

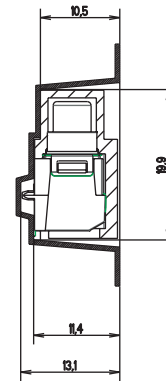

Dimensions are shown: mm
Specifications and dimensions subject to change

K5V Illuminated Tact Switch

Tactile Switches

B

K5V THT

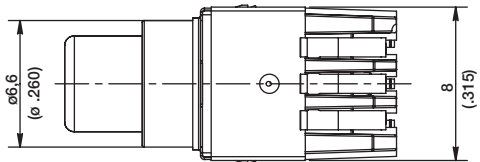
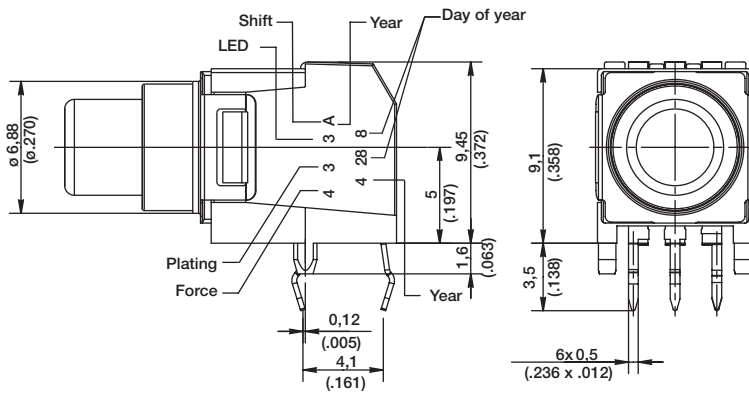
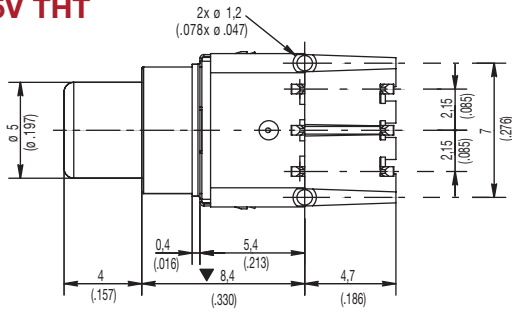

ELECTRICAL DIAGRAM

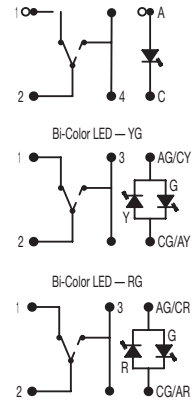

RECOMMENDED PCB LAYOUT (WITH HOLES) TOP VIEW

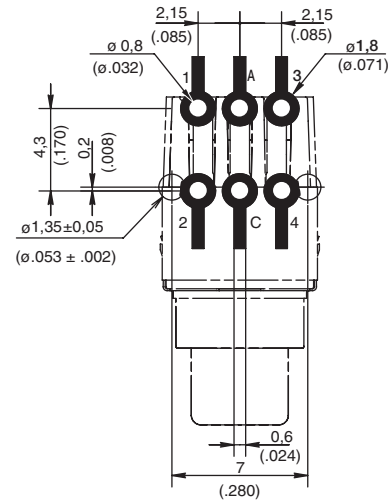

TRAY

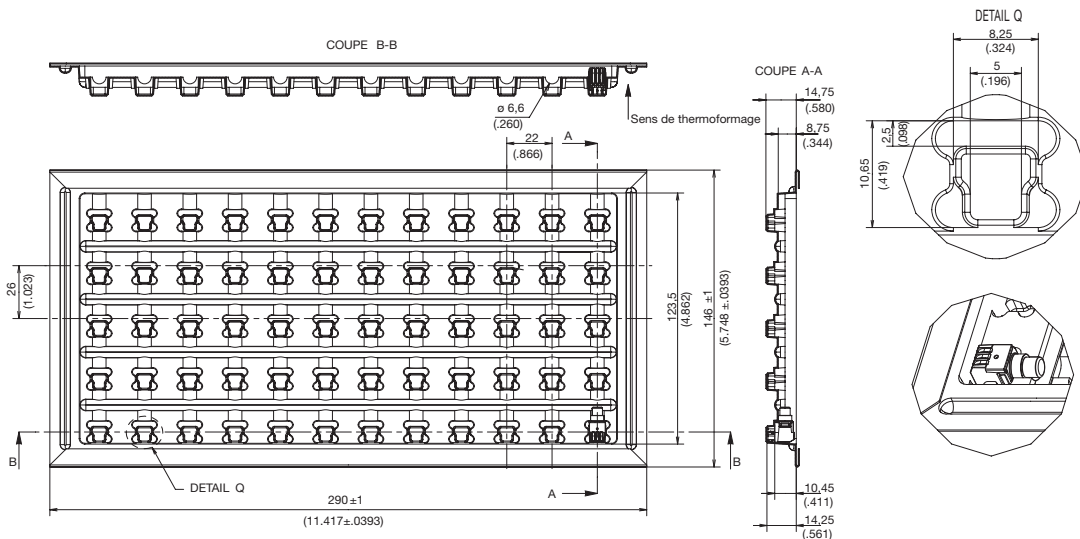

Dimensions are shown: mm
Specifications and dimensions subject to change

K5V Illuminated Tact Switch

Tactile Switches

K5V PM

ELECTRICAL DIAGRAM

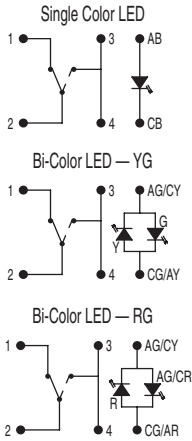

TERMINAL REFERENCES

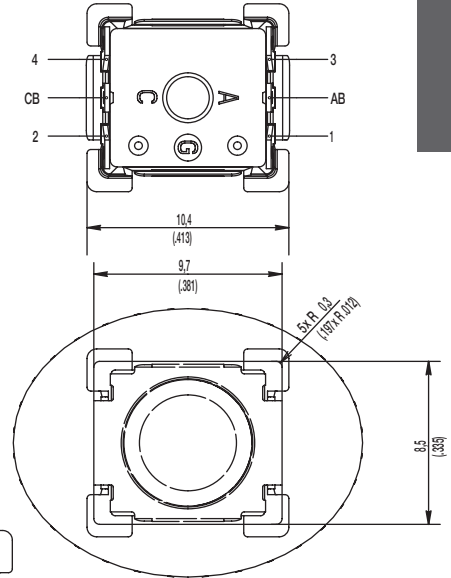

PRODUCT IDENTIFICATION AND DATE CODES

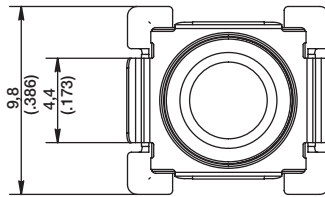
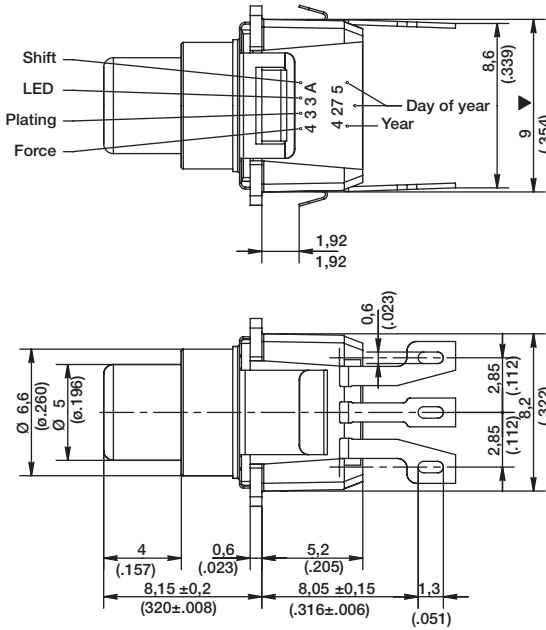

TRAY

SUITABLE FOR PANEL THICKNESS OF 1.8MM MAX

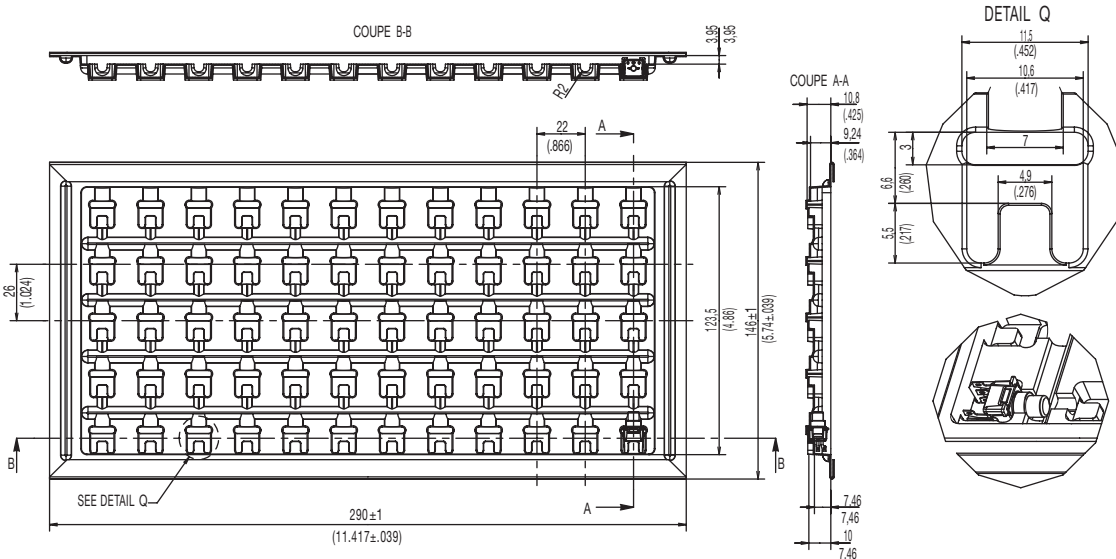

Dimensions are shown: mm
Specifications and dimensions subject to change

Данный компонент на территории Российской Федерации

Вы можете приобрести в компании MosChip.

Для оперативного оформления запроса Вам необходимо перейти по данной ссылке:

<http://moschip.ru/get-element>

Вы можете разместить у нас заказ для любого Вашего проекта, будь то серийное производство или разработка единичного прибора.

В нашем ассортименте представлены ведущие мировые производители активных и пассивных электронных компонентов.

Нашей специализацией является поставка электронной компонентной базы двойного назначения, продукции таких производителей как XILINX, Intel (ex.ALTERA), Vicor, Microchip, Texas Instruments, Analog Devices, Mini-Circuits, Amphenol, Glenair.

Сотрудничество с глобальными дистрибьюторами электронных компонентов, предоставляет возможность заказывать и получать с международных складов практически любой перечень компонентов в оптимальные для Вас сроки.

На всех этапах разработки и производства наши партнеры могут получить квалифицированную поддержку опытных инженеров.

Система менеджмента качества компании отвечает требованиям в соответствии с ГОСТ Р ИСО 9001, ГОСТ РВ 0015-002 и ЭС РД 009

Офис по работе с юридическими лицами:

105318, г.Москва, ул.Щербаковская д.3, офис 1107, 1118, ДЦ «Щербаковский»

Телефон: +7 495 668-12-70 (многоканальный)

Факс: +7 495 668-12-70 (доб.304)

E-mail: info@moschip.ru

Skype отдела продаж:

moschip.ru

moschip.ru_4

moschip.ru_6

moschip.ru_9