

# XPT IGBT Module

$V_{CES} = 1200\text{ V}$   
 $I_{C25} = 360\text{ A}$   
 $V_{CE(sat)} = 1.8\text{ V}$

Boost chopper + free wheeling Diodes + NTC

**Part number**  
 MIXA225RF1200TSF

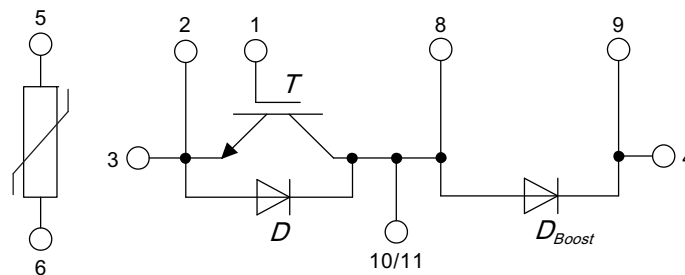
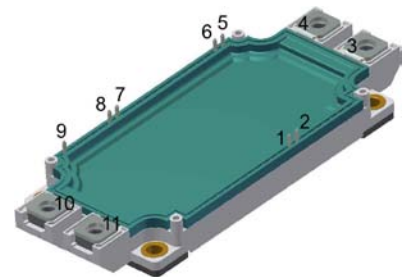

### Features / Advantages:

- High level of integration - only one power semiconductor module required for the whole drive
- Rugged XPT design (Xtreme light Punch Through) results in:
  - short circuit rated for 10  $\mu$ sec.
  - very low gate charge
  - low EMI
  - square RBSOA @ 3x Ic
- Thin wafer technology combined with the XPT design results in a competitive low  $V_{CE(sat)}$
- Temperature sense included
- SONIC™ diode
  - fast and soft reverse recovery
  - low operating forward voltage

### Applications:

- Brake for AC motor drives
- Boost chopper
- Switch reluctance drives

### Package: SimBus F

- Industry standard outline
- RoHS compliant
- Soldering pins for PCB mounting
- Height: 17 mm
- Base plate:
  - Copper internally DCB isolated
- Advanced power cycling

IGBT <i>T</i>				Ratings			
Symbol	Definitions	Conditions	min.	typ.	max.	Unit	
$V_{CES}$	collector emitter voltage	$T_{VJ} = 25^{\circ}\text{C}$ to $125^{\circ}\text{C}$			1200	V	
$V_{GES}$	max. DC gate voltage				$\pm 20$	V	
$V_{GEM}$	max. transient gate emitter voltage				$\pm 30$	V	
$I_{C25}$	collector current	$T_C = 25^{\circ}\text{C}$			360	A	
$I_{C80}$		$T_C = 80^{\circ}\text{C}$			250	A	
$P_{tot}$	total power dissipation	$T_C = 25^{\circ}\text{C}$			1100	W	
$V_{CE(sat)}$	collector emitter saturation voltage	$I_C = 225\text{ A}; V_{GE} = 15\text{ V}$		1.8	2.1	V	
				2.1		V	
$V_{GE(th)}$	gate emitter threshold voltage	$I_C = 9\text{ mA}; V_{GE} = V_{CE}$	5.4		6.5	V	
$I_{CES}$	collector emitter leakage current	$V_{CE} = V_{CES}; V_{GE} = 0\text{ V}$			0.3	mA	
				0.3		mA	
$I_{GES}$	gate emitter leakage current	$V_{GE} = \pm 20\text{ V}; V_{CE} = 0\text{ V}$			1.5	$\mu\text{A}$	
$Q_{G(on)}$	total gate charge	$V_{CE} = 600\text{ V}; V_{GE} = 15\text{ V}; I_C = 225\text{ A}$		690		nC	
$t_{d(on)}$	turn-on delay time	inductive load $V_{CE} = 600\text{ V}; I_C = 225\text{ A}$ $V_{GE} = \pm 15\text{ V}; R_G = 3.3\ \Omega$		60		ns	
$t_r$	current rise time		$T_{VJ} = 125^{\circ}\text{C}$		70		ns
$t_{d(off)}$	turn-off delay time				280		ns
$t_f$	current fall time				310		ns
$E_{on}$	turn-on energy per pulse				20		mJ
$E_{off}$	turn-off energy per pulse				27		mJ
<b>RBSOA</b>	reverse bias safe operating area	$V_{GE} = \pm 15\text{ V}; R_G = 3.3\ \Omega$					
$I_{CM}$		$V_{CEmax} = 1200\text{ V}$			500	A	
<b>SCSOA</b>	short circuit safe operating area	$V_{CEmax} = 1200\text{ V}$					
$t_{SC}$	short circuit duration	$V_{CE} = 900\text{ V}; V_{GE} = \pm 15\text{ V};$			10	$\mu\text{s}$	
$I_{SC}$	short circuit current	$R_G = 3.3\ \Omega; \text{non-repetitive}$		900		A	
$R_{thJC}$	thermal resistance junction to case				0.115	K/W	
$R_{thCH}$	thermal resistance case to heatsink			0.045		K/W	
<b>Diode <math>D_{Boost}</math></b>							
$V_{RRM}$	max. repetitive reverse voltage				1200	V	
$I_{F25}$	forward current				265	A	
$I_{F80}$					185	A	
$V_F$	forward voltage	$I_F = 225\text{ A}; V_{GE} = 0\text{ V}$		1.80	2.10	V	
				1.70		V	
$I_R$	reverse current	$V_R = V_{RRM}$			0.3	mA	
				0.3		mA	
$Q_{rr}$	reverse recovery charge	$V_R = 600\text{ V}$ $-di_F/dt = 3300\text{ A}/\mu\text{s}$ $I_F = 225\text{ A}; V_{GE} = 0\text{ V}$		32		$\mu\text{C}$	
$I_{RM}$	max. reverse recovery current		$T_{VJ} = 125^{\circ}\text{C}$		250		A
$t_{rr}$	reverse recovery time				340		ns
$E_{rec}$	reverse recovery energy				11.7		mJ
$R_{thJC}$	thermal resistance junction to case				0.145	K/W	
$R_{thCH}$	thermal resistance case to heatsink			0.05		K/W	

Diode D				Ratings			
Symbol	Definitions	Conditions	min.	typ.	max.	Unit	
$V_{RRM}$	max. repetitive reverse voltage				1200	V	
$I_{F25}$	forward current				65	A	
$I_{F80}$					45	A	
$V_F$	forward voltage	$I_F = 60 \text{ A}; V_{GE} = 0 \text{ V}$		2.0	2.2	V	
				2.0		V	
$I_R$	reverse current * not applicable, see Ices value of IGBT T	$V_R = V_{RRM}$		*	*	mA mA	
$R_{thJC}$	thermal resistance junction to case				0.5	K/W	
$R_{thCH}$	thermal resistance case to heatsink			0.2		K/W	

Package SimBus F				Ratings			
Symbol	Definitions	Conditions	min.	typ.	max.	Unit	
$I_{RMS}$	RMS current	per terminal				A	
$T_{stg}$	storage temperature		-40		125	°C	
$T_{VJM}$	virtual junction temperature		-40		150	°C	
<b>Weight</b>				350		g	
					3400	V~	
			$I_{ISOL} \leq 1 \text{ mA}; 50/60 \text{ Hz}$				
$M_D$	mounting torque (M5)		3		6	Nm	
$M_T$	terminal torque (M6)		3		6	Nm	
$d_{Spp/App}$	creepage distance on surface / striking distance through air	terminal to terminal	12.7			mm	
$d_{Spb/Apb}$		terminal to backside	10.0			mm	
$V_{ISOL}$	isolation voltage	$t = 1 \text{ second}$	3000			V	
		$t = 1 \text{ minute}$	2500			V	
		50/60 Hz, RMS, $I_{ISOL} \leq 1 \text{ mA}$					
$R_{term-chip}$	resistance terminal to chip	$V = V_{CEsat} + 2x R_{term-chip} \cdot I_C$ resp. $V = V_F + 2x R \cdot I_F$		0.65		mΩ	

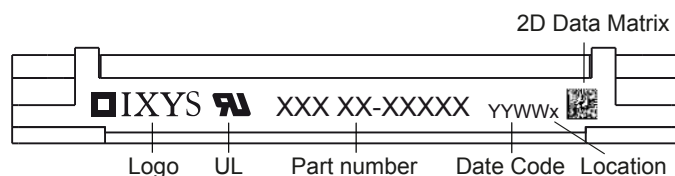

**Part number**

M = Module  
 I = IGBT  
 X = XPT  
 A = standard  
 225 = Current Rating [A]  
 RF = Boost / brake chopper + free wheeling diode  
 1200 = Reverse Voltage [V]  
 T = NTC  
 EH = E3-Pack

Ordering	Part Name	Marking on Product	Delivering Mode	Base Qty	Ordering Code
Standard	MIXA225RF1200TSF	MIXA225RF1200TSF	Box	3	511581

Temperature Sensor NTC			Ratings			
Symbol	Definitions	Conditions	min.	typ.	max.	Unit
$R_{25}$	resistance	$T_C = 25^\circ\text{C}$	4.75	5.0	5.25	kΩ
$B_{25/50}$	temperature coefficient			3375		K

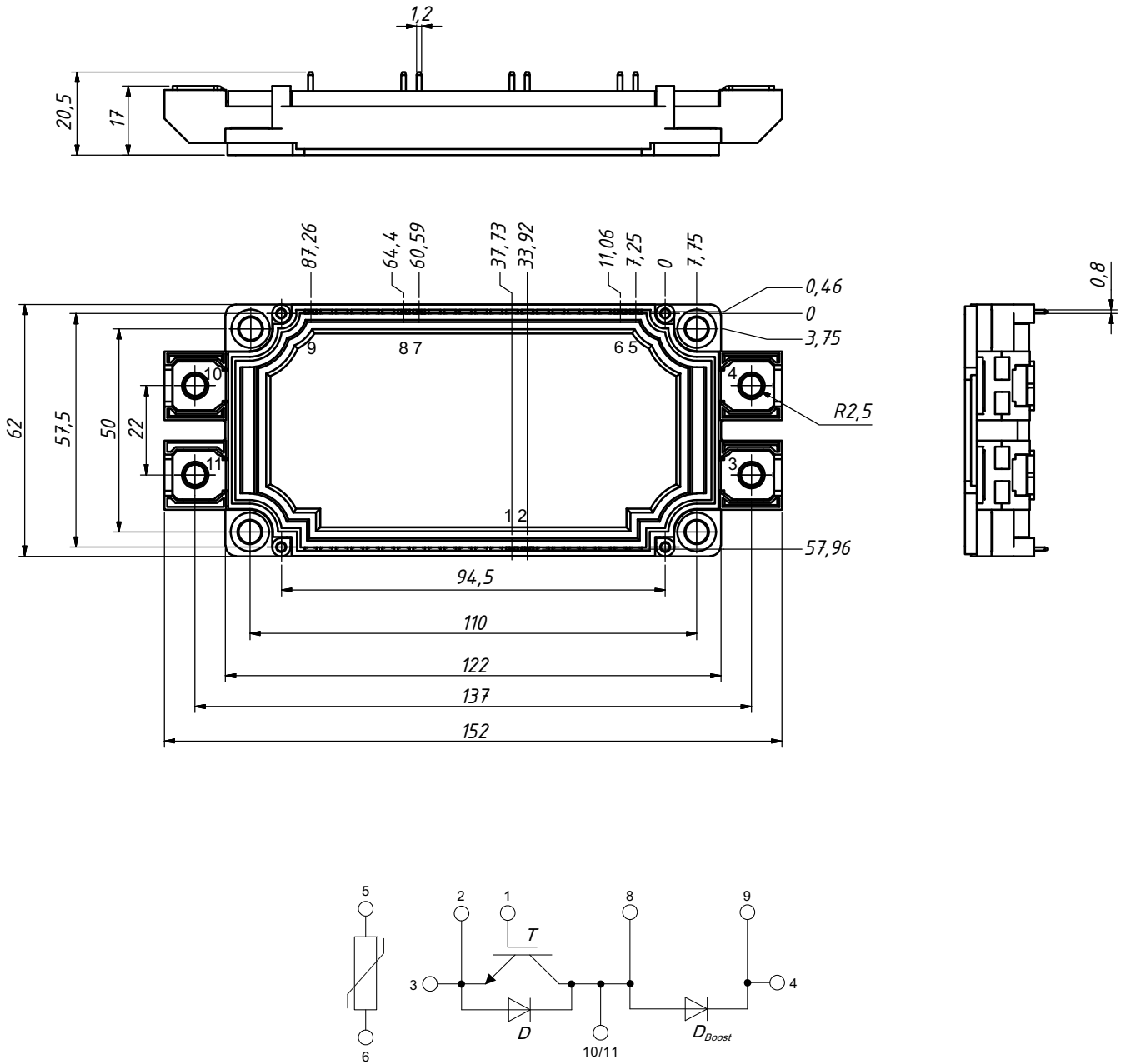
Outlines SimBus F



## Данный компонент на территории Российской Федерации

### Вы можете приобрести в компании MosChip.

Для оперативного оформления запроса Вам необходимо перейти по данной ссылке:

<http://moschip.ru/get-element>

Вы можете разместить у нас заказ для любого Вашего проекта, будь то серийное производство или разработка единичного прибора.

В нашем ассортименте представлены ведущие мировые производители активных и пассивных электронных компонентов.

Нашей специализацией является поставка электронной компонентной базы двойного назначения, продукции таких производителей как XILINX, Intel (ex.ALTERA), Vicor, Microchip, Texas Instruments, Analog Devices, Mini-Circuits, Amphenol, Glenair.

Сотрудничество с глобальными дистрибьюторами электронных компонентов, предоставляет возможность заказывать и получать с международных складов практически любой перечень компонентов в оптимальные для Вас сроки.

На всех этапах разработки и производства наши партнеры могут получить квалифицированную поддержку опытных инженеров.

Система менеджмента качества компании отвечает требованиям в соответствии с ГОСТ Р ИСО 9001, ГОСТ РВ 0015-002 и ЭС РД 009

### Офис по работе с юридическими лицами:

105318, г.Москва, ул.Щербаковская д.3, офис 1107, 1118, ДЦ «Щербаковский»

Телефон: +7 495 668-12-70 (многоканальный)

Факс: +7 495 668-12-70 (доб.304)

E-mail: [info@moschip.ru](mailto:info@moschip.ru)

Skype отдела продаж:

moschip.ru

moschip.ru\_4

moschip.ru\_6

moschip.ru\_9