

# PSM-ME-RS485/RS485-P

Order No.: 2744429



<http://eshop.phoenixcontact.net/phoenix/treeViewClick.do?UID=2744429>

Repeater, for potential separation and range increase in RS-485 2-wire bus systems, 3-way isolation, rail-mountable



**RS-485**

## Commercial data

EAN	 4 017918 171797
Pack	1 pcs.
Customs tariff	85176200
Gross weight in pieces	0.1896 KG
Net weight per piece (exclusive packing)	0.1896 KG
Catalog page information	Page 481 (IF-2011)

## Product notes

WEEE/RoHS-compliant since:  
07/14/2006



<http://www.download.phoenixcontact.com>  
Please note that the data given here has been taken from the online catalog. For comprehensive information and data, please refer to the user documentation. The General Terms and Conditions of Use apply to Internet downloads.

## Technical data

### Serial interface

Interface 1	RS-485 interface, in acc. with EIA/TIA-485, DIN 66259-4/RS-485 2-wire
Operating mode	Semi-duplex
File format/coding	UART (11/10 bit switchable; NRZ)

Data direction switching	Automatic control, min. station response time 1 bits
Termination resistor	390 Ω
	220 Ω
	390 Ω (Can be connected)
Transmission medium	2-wire twisted pair, shielded
Transmission length	max. 1200 m (depends on transmission speed, bus system and cable type)
Cascadability	9 (4,8 - 93,75 kbps)
	7 (115.2 - 136 kbps)
Connection method	Pluggable screw connection
Conductor cross section stranded min.	0.2 mm <sup>2</sup>
Conductor cross section stranded max.	2.5 mm <sup>2</sup>
Conductor cross section AWG/kcmil min.	24
Conductor cross section AWG/kcmil max	14
Serial transmission speed	4.8/ 9.6/ 19.2/ 38.4/ 57.6/ 75/ 93.75/ 115.2/ 136/ 187.5/ 375/ 500/ 1500 kbps
Interface 2	RS-485 interface, in acc. with EIA/TIA-485, DIN 66259-4/RS-485 2-wire
Operating mode	Semi-duplex
File format/coding	UART (11/10 bit switchable; NRZ)
Data direction switching	Automatic control, min. station response time 1 bits
Transmission medium	2-wire twisted pair, shielded
Transmission length	1200 m (depends on transmission speed, bus system and cable type)
Cascadability	9 (4,8 - 93,75 kbps)
Conductor cross section stranded min.	0.2 mm <sup>2</sup>
Conductor cross section stranded max.	2.5 mm <sup>2</sup>
Conductor cross section AWG/kcmil min.	24
Conductor cross section AWG/kcmil max	14
Serial transmission speed	4.8/ 9.6/ 19.2/ 38.4/ 57.6/ 75/ 93.75/ 115.2/ 136/ 187.5/ 375/ 500/ 1500 kbps
<b>Power supply</b>	
Nominal supply voltage	24 V AC/DC ±20 %
Typical current consumption	90 mA (24 V DC)
<b>General data</b>	
Transmission channels	2 (1/1), TD, RD, half duplex

Bit delay	< 200 ns
Bit distortion	< 1.5 %
Bit distortion, input	max. $\pm$ 35 %
Bit distortion, output	< 3.6 %
Width	22.5 mm
Height	99 mm
Depth	114.5 mm
Ambient temperature (operation)	0 °C ... 55 °C
Ambient temperature (storage/transport)	-40 °C ... 85 °C
Permissible humidity (operation)	10 % ... 95 % (no condensation)
Altitude	5000 m (For restrictions see manufacturer's declaration)
Electrical isolation	(VCC // RS-485 (A) // RS-485 (B))
Test voltage data interfaces	2 kV AC
Test voltage data interface/power supply	2 kV AC
	2 kV
Electromagnetic compatibility	Conformance with EMC Directive 2004/108/EC
Noise emission	EN 50 081-1
Noise immunity	EN 61000-6-2:2005
Net weight	130 g
Housing material	PA
Color	green
MTBF	1849 Years (Telcordia standard, 25°C temperature, 21% operating cycle (5 days a week, 8 hours a day))
	385 Years (Telcordia standard, 40°C temperature, 34.25% operating cycle (5 days a week, 12 hours a day))
UL, USA / Canada	508 recognized
	Class I, Div. 2, Groups A, B, C, D

#### Certificates / Approvals



Certification	cULus Recognized, GOST, DNV
Certification Ex:	cUL Recognized
Certifications applied for:	cUL / UL

**Accessories**

Item	Designation	Description
------	-------------	-------------

**Assembly**

2853899	ME-SAS	Shield connection clamp for printed circuit terminal block
---------	--------	--

**General**

2313944	PSI-TERMINATOR-PB	Active termination resistor with redundant voltage supply for PROFIBUS and RS-485 bus systems. Compact design. Electrical isolation between supply and data interface. Bus termination can be switched. Integrated programming interface.
---------	-------------------	---

**Tools**

1204517	SZF 1-0,6X3,5	Actuation tool, for ST terminal blocks, also suitable for use as a bladed screwdriver, size: 0.6 x 3.5 x 100 mm, 2-component grip, with non-slip grip
---------	---------------	---

**Diagrams/Drawings**

Application drawing

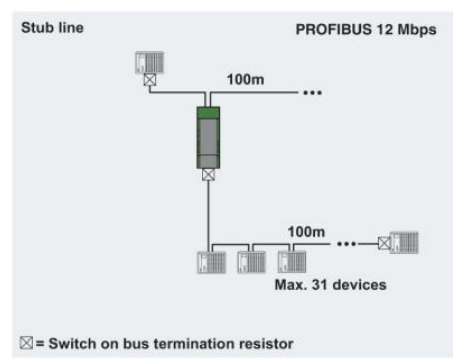
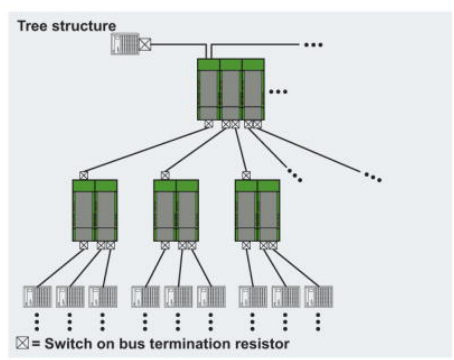
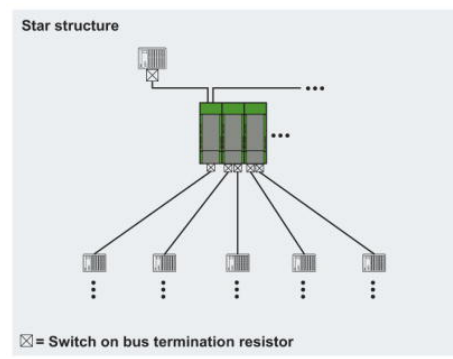
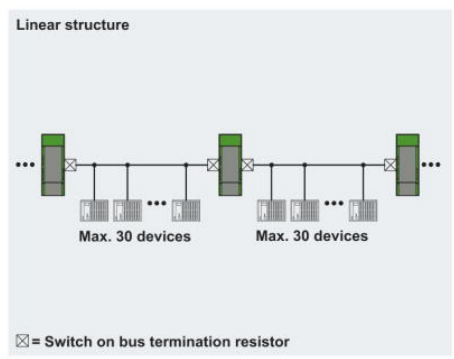

### Circuit diagram

---

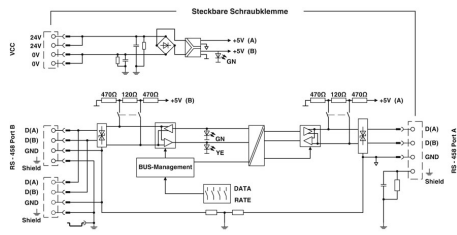

**Address**

PHOENIX CONTACT Ltd  
Halesfield 13  
Telford Shropshire TF7 4PG,GB  
Phone 01952 681 700  
Fax 01952 681 799  
<http://www.phoenixcontact.co.uk>



© 2013 Phoenix Contact  
Technical modifications reserved;

## Данный компонент на территории Российской Федерации

### Вы можете приобрести в компании MosChip.

Для оперативного оформления запроса Вам необходимо перейти по данной ссылке:

<http://moschip.ru/get-element>

Вы можете разместить у нас заказ для любого Вашего проекта, будь то серийное производство или разработка единичного прибора.

В нашем ассортименте представлены ведущие мировые производители активных и пассивных электронных компонентов.

Нашей специализацией является поставка электронной компонентной базы двойного назначения, продукции таких производителей как XILINX, Intel (ex.ALTERA), Vicor, Microchip, Texas Instruments, Analog Devices, Mini-Circuits, Amphenol, Glenair.

Сотрудничество с глобальными дистрибьюторами электронных компонентов, предоставляет возможность заказывать и получать с международных складов практически любой перечень компонентов в оптимальные для Вас сроки.

На всех этапах разработки и производства наши партнеры могут получить квалифицированную поддержку опытных инженеров.

Система менеджмента качества компании отвечает требованиям в соответствии с ГОСТ Р ИСО 9001, ГОСТ РВ 0015-002 и ЭС РД 009

### Офис по работе с юридическими лицами:

105318, г.Москва, ул.Щербаковская д.3, офис 1107, 1118, ДЦ «Щербаковский»

Телефон: +7 495 668-12-70 (многоканальный)

Факс: +7 495 668-12-70 (доб.304)

E-mail: [info@moschip.ru](mailto:info@moschip.ru)

Skype отдела продаж:

moschip.ru

moschip.ru\_4

moschip.ru\_6

moschip.ru\_9