

Load Switch ICs for Portable Equipment

BD2202G-LB BD2206G-LB

General Description

This product guarantees long time support in Industrial market. The High-side switch, which has over-current protection function, is used for the power supply line of a memory card slot. In the switch part, an N-channel MOSFET with low ON resistance has been 1 circuit integrated. The switch goes OFF when the over-current condition lasts longer than the over-current shutdown time. The OFF switch is set to latch off mode. The operating voltage range is 2.7V to 3.6V and the current limit value is set on 400mA, 1A. Moreover, functions of soft start, under voltage lockout, and over temperature protection are integrated.

Features

- Long time support a product for Industrial applications.
- Single low on-resistance (Typ. = 150mΩ) Nch MOS FET
- Continuous load current
 - 0.2A: (BD2202G)
 - 0.5A: (BD2206G)
- Control input logic: Active-High
- Soft start function
- Over current protection circuit
- Over temperature protection circuit
- Under voltage lockout

Key Specifications

- Input voltage range: 2.7V to 3.6V
- ON resistance : 150mΩ(Typ.)
- Over current threshold:
 - BD2202G 0.25A min., 1.0A max.
 - BD2206G 0.8A min., 1.6A max.
- Standby current: 0.01μA (Typ.)
- Operating temperature range: -25°C to +85°C

Package

SSOP5 W(Typ.) D(Typ.) H (Max.)
2.90mm x 2.80mm x 1.25mm

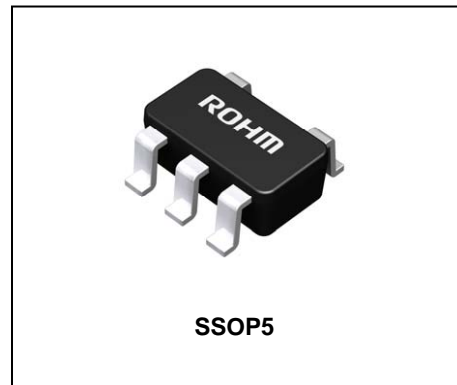

Applications

Industrial Equipment, Memory card slots of STB, Digital still camera, Cell Phones, Notebook PC.

Typical Application Circuit

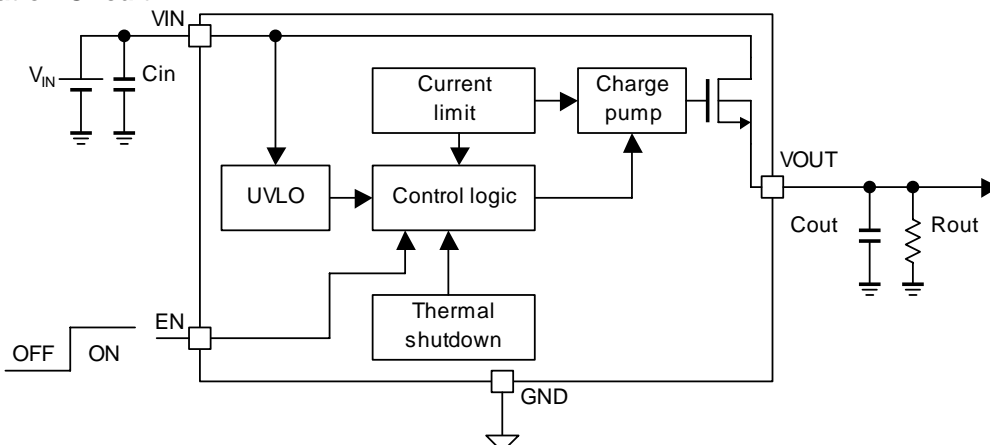

Lineup

Over current threshold			Control input logic	Package		Orderable Part Number
Min.	Typ.	Max.				
0.25A	-	1.0A	High	SSOP5	Reel of 3000	BD2202G-LBTR
0.8A	-	1.6A	High	SSOP5	Reel of 3000	BD2206G-LBTR

Block Diagram

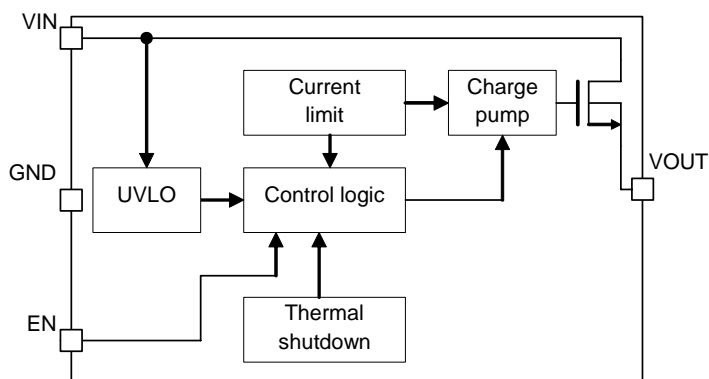

Pin Configuration

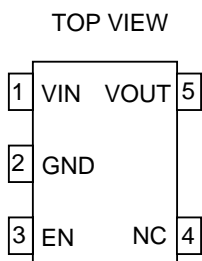

Pin Description

Pin Number	Pin Name	I / O	Pin function
1	VIN	I	Power supply input terminal. Input terminal to the power switch and supply of the internal circuit.
2	GND	I	Ground.
3	EN	I	Power Switch enable input. Active-High Switch on input. Logic high turns the switch on.
4	N.C	-	No connection.
5	VOUT	O	Power switch output.

Absolute Maximum Ratings

Parameter	Symbol	Limits	Unit
Supply voltage	V _{IN}	-0.3 to 6.0	V
EN voltage	V _{EN}	-0.3 to 6.0	V
OUT voltage	V _{OUT}	-0.3 to V _{IN} + 0.3	V
Storage temperature	T _{STG}	-55 to 150	°C
Power dissipation	PD	675 ^{*1}	mW

*1 Mounted on 70mm * 70mm * 1.6mm grass-epoxy PCB. Derating: 5.4mW/°C for operating above Ta=25°C

Recommended Operating Range

◎BD2202G

Parameter	Symbol	Limits	Unit
Operating voltage range	V _{IN}	2.7 to 3.6	V
Operating temperature range	T _{OPR}	-25 to 85	°C
Operating load current	I _{LO}	0 to 200	mA

◎BD2206G

Parameter	Symbol	Limits	Unit
Operating voltage range	V _{IN}	2.7 to 3.6	V
Operating temperature range	T _{OPR}	-25 to 85	°C
Operating load current	I _{LO}	0 to 500	mA

Electrical Characteristics

◎BD2202G (Unless otherwise specified, V_{IN} = 3.3V, Ta = 25°C)

DC characteristics

Parameter	Symbol	Limits			Unit	Condition
		Min.	Typ.	Max.		
Operating current	I _{DD}	-	70	90	μA	V _{EN} = 3.3V, V _{OUT} = OPEN
Standby current	I _{STB}	-	0.01	1	μA	V _{EN} = 0V, V _{OUT} = OPEN
EN input voltage	V _{EN}	2.0	-	-	V	High level input
		-	-	0.8	V	Low level input
EN input current	I _{EN}	-1.0	0.01	1.0	μA	V _{EN} = 0V or V _{EN} = 3.3V
ON resistance	R _{ON}	-	150	200	mΩ	I _{OUT} = 50mA
Over-current Threshold	I _{TH}	0.25	-	1.0	A	
Short-circuit output current	I _{SC}	200	-	600	mA	V _{OUT} = 0V
Output leak current	I _{LEAK}	-	0.01	10	μA	V _{EN} = 0V, V _{OUT} = 0V
UVLO threshold	V _{TUVH}	2.1	2.3	2.5	V	V _{IN} increasing
	V _{TUVL}	2.0	2.2	2.4	V	V _{IN} decreasing

AC characteristics

Parameter	Symbol	Limits			Unit	Condition
		Min.	Typ.	Max.		
Output rise time	T _{ON1}	0.25	1.2	6	ms	R _{OUT} =500Ω, C _{OUT} =0.1μF
Output turn on time	T _{ON2}	0.4	2	10	ms	R _{OUT} =500Ω, C _{OUT} =0.1μF
Output fall time	T _{OFF1}	50	100	200	μs	R _{OUT} =500Ω, C _{OUT} =0.1μF
Output turn off time	T _{OFF2}	50	100	200	μs	R _{OUT} =500Ω, C _{OUT} =0.1μF
Over current shutdown time 1	T _{BLANK1}	5	10	15	ms	At continuous over current
Over current shutdown time 2	T _{BLANK2}	3	-	15	ms	At discontinuous over current

Electrical Characteristics - continued©BD2206G (Unless otherwise specified, $V_{IN} = 3.3V$, $T_a = 25^\circ C$)

DC characteristics

Parameter	Symbol	Limits			Unit	Condition
		Min.	Typ.	Max.		
Operating current	I_{DD}	-	70	90	μA	$V_{EN} = 3.3V$, $V_{OUT} = OPEN$
Standby current	I_{STB}	-	0.01	1	μA	$V_{EN} = 0V$, $V_{OUT} = OPEN$
EN input voltage	V_{EN}	2.0	-	-	V	High level input
		-	-	0.8	V	Low level input
EN input current	I_{EN}	-1.0	0.01	1.0	μA	$V_{EN} = 0V$ or $V_{EN} = 3.3V$
ON resistance	R_{ON}	-	150	200	$m\Omega$	$I_{OUT} = 50mA$
Over-current Threshold	I_{TH}	0.8	-	1.6	A	
Short-circuit output current	I_{SC}	750	-	1350	mA	$V_{OUT} = 0V$
Output leak current	I_{LEAK}	-	0.01	10	μA	$V_{EN} = 0V$, $V_{OUT} = 0V$
UVLO threshold	V_{TUVH}	2.1	2.3	2.5	V	V_{IN} increasing
	V_{TUVL}	2.0	2.2	2.4	V	V_{IN} decreasing

AC characteristics

Parameter	Symbol	Limits			Unit	Condition
		Min.	Typ.	Max.		
Output rise time	T_{ON1}	0.25	1.2	6	ms	$R_{OUT}=500\Omega$, $C_{OUT}=0.1\mu F$
Output turn on time	T_{ON2}	0.4	2	10	ms	$R_{OUT}=500\Omega$, $C_{OUT}=0.1\mu F$
Output fall time	T_{OFF1}	50	100	200	μs	$R_{OUT}=500\Omega$, $C_{OUT}=0.1\mu F$
Output turn off time	T_{OFF2}	50	100	200	μs	$R_{OUT}=500\Omega$, $C_{OUT}=0.1\mu F$
Over current shutdown time 1	T_{BLANK1}	5	10	15	ms	At continuous over current
Over current shutdown time 2	T_{BLANK2}	3	-	15	ms	At discontinuous over current

Measurement Circuits

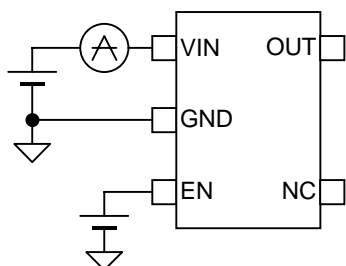

A. Operating current

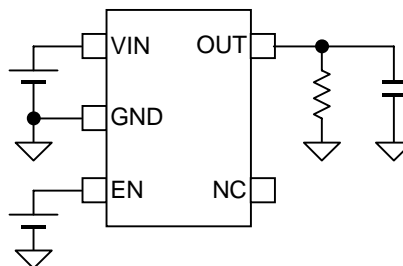

B. EN input voltage, Output rise / fall time

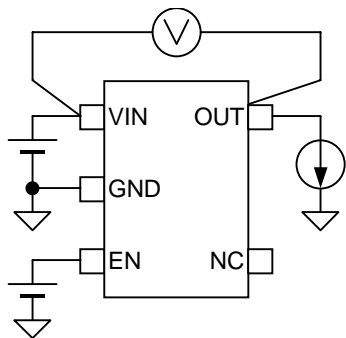

C.ON resistance

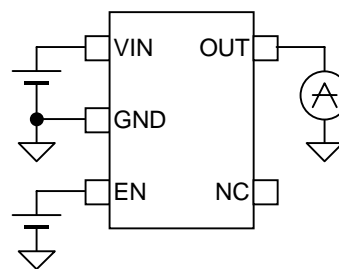

D. Over current protection characteristics

Figure 1. Measurement circuits

Timing Diagrams

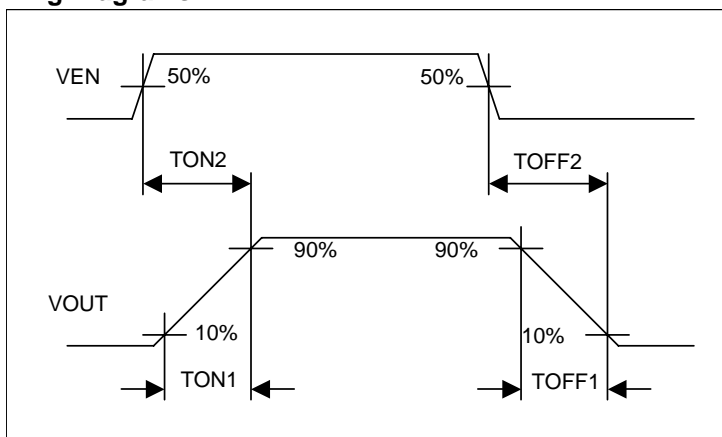

Figure 2. Switch Turn on / off time

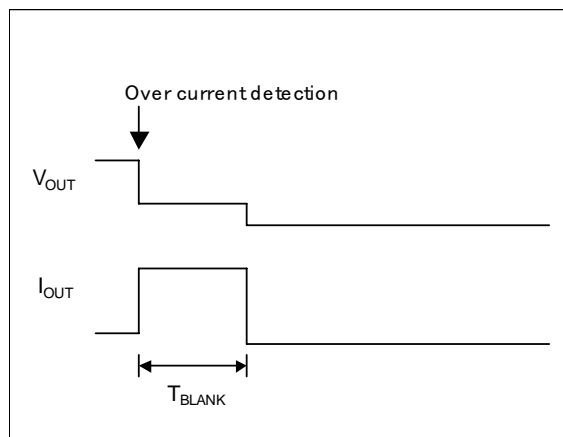

Figure 3. Over current limits characteristics

Typical Performance Curves

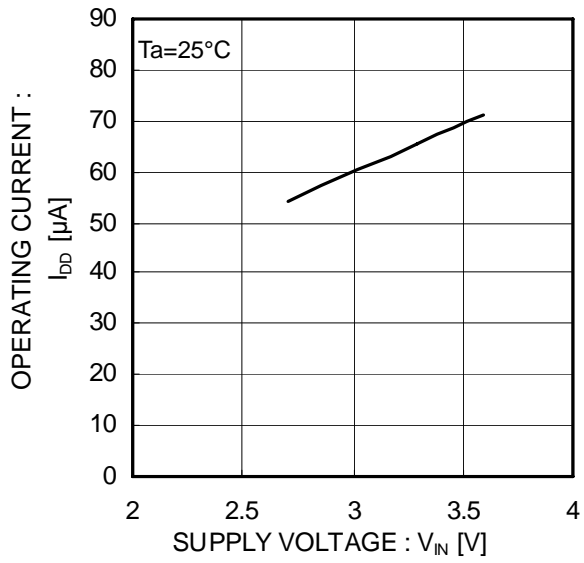

Figure 4. Operating current
EN Enable

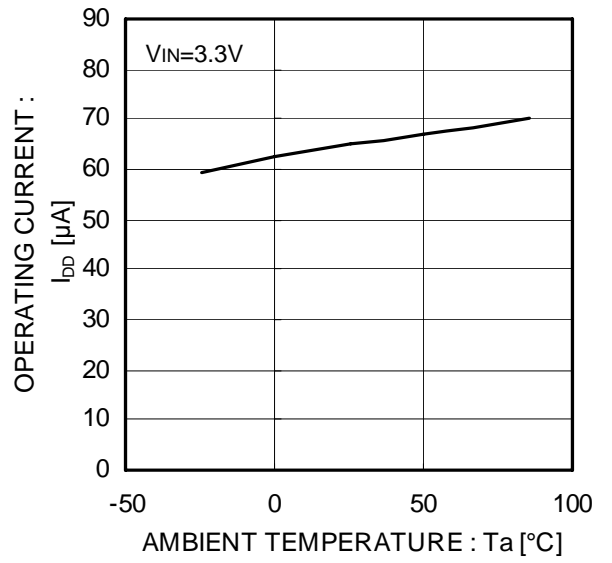

Figure 5. Operating current
EN Enable

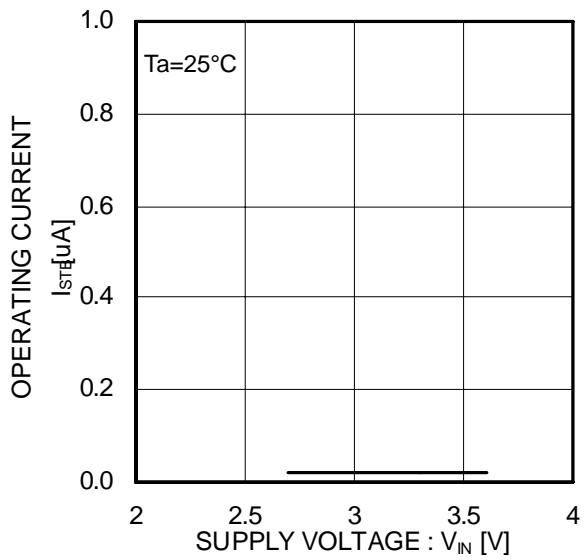

Figure 6. Operating current
EN Disable

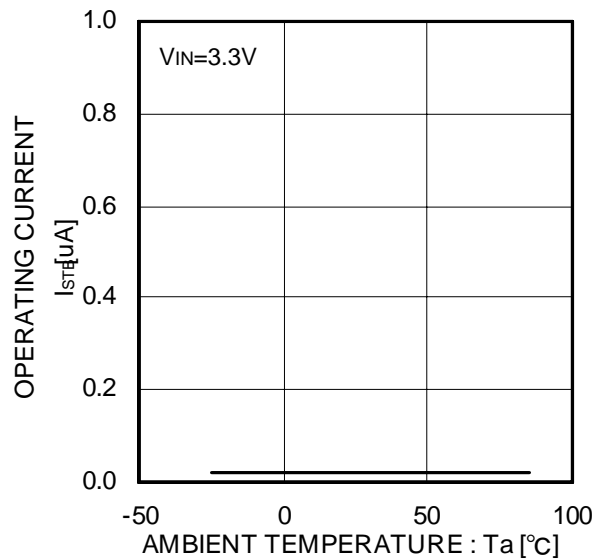

Figure 7. Operating current
EN Disable

Typical Performance Curves - continued

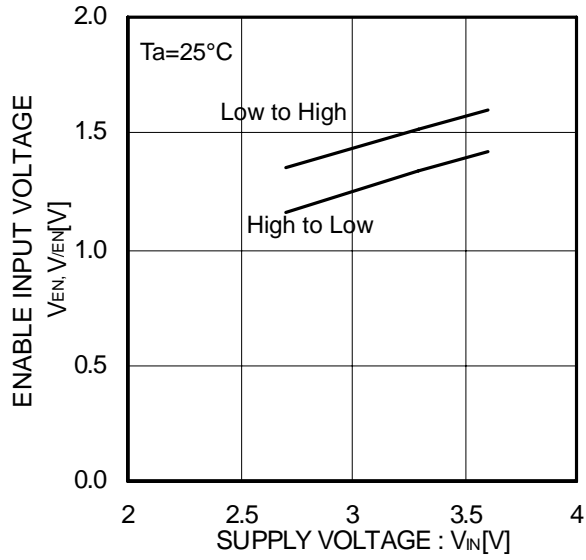

Figure 8. EN input voltage

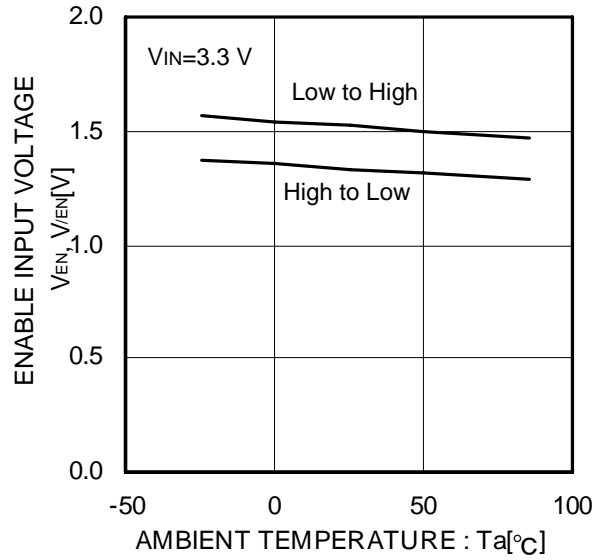

Figure 9. EN input voltage

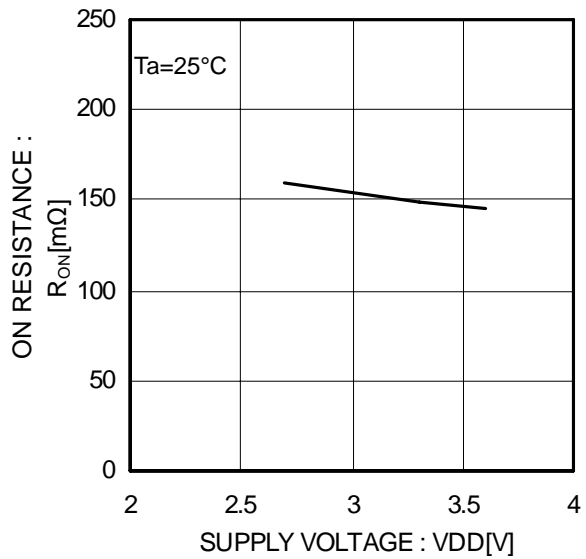

Figure 10. ON resistance

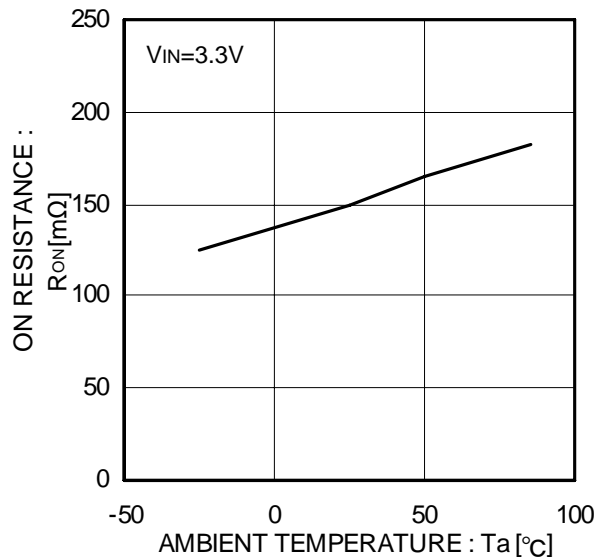

Figure 11. ON resistance

Typical Performance Curves - continued

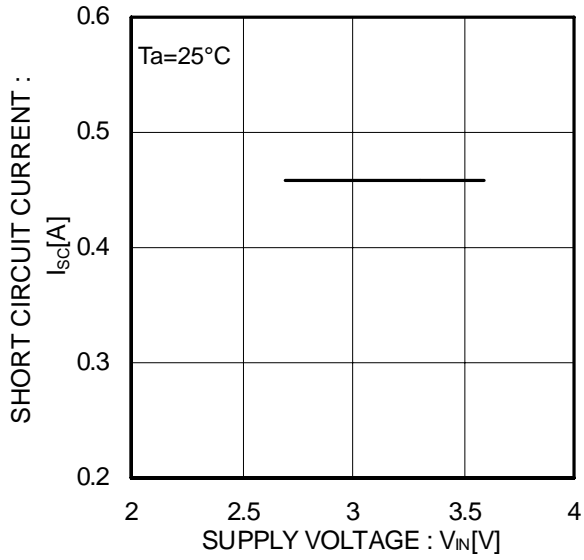

Figure 12. Short circuit output current (BD2202G)

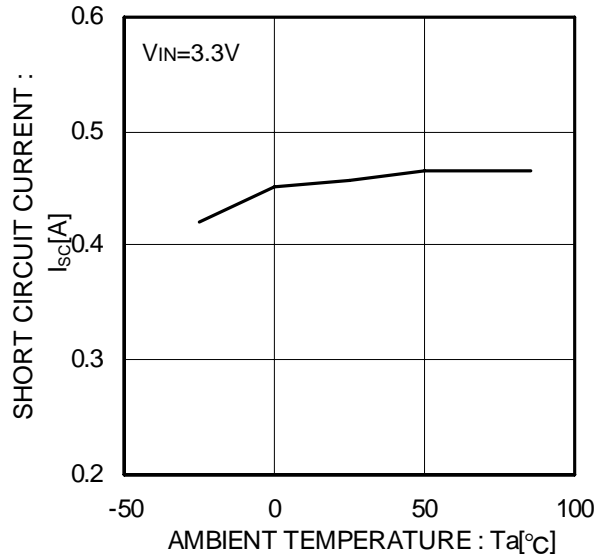

Figure 13. Short circuit output current (BD2202G)

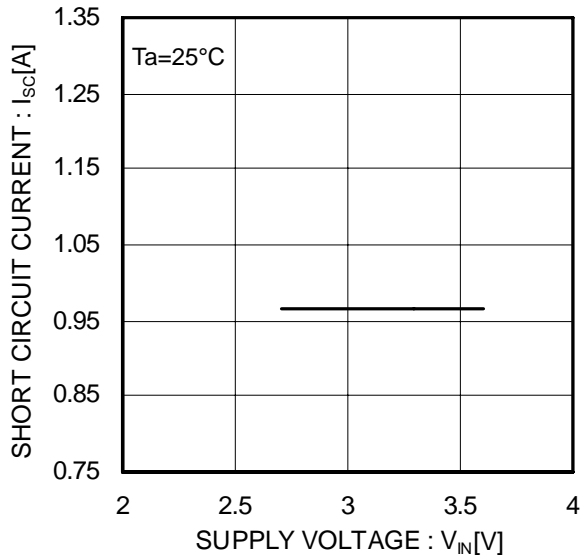

Figure 14. Short circuit output current (BD2206G)

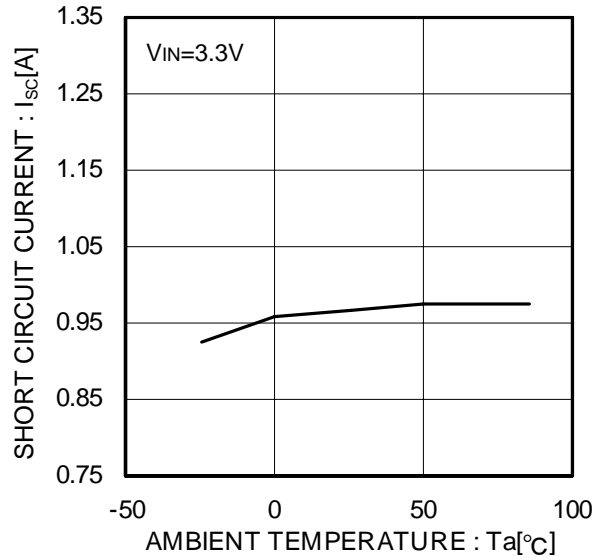

Figure 15. Short circuit output current (BD2206G)

Typical Performance Curves - continued

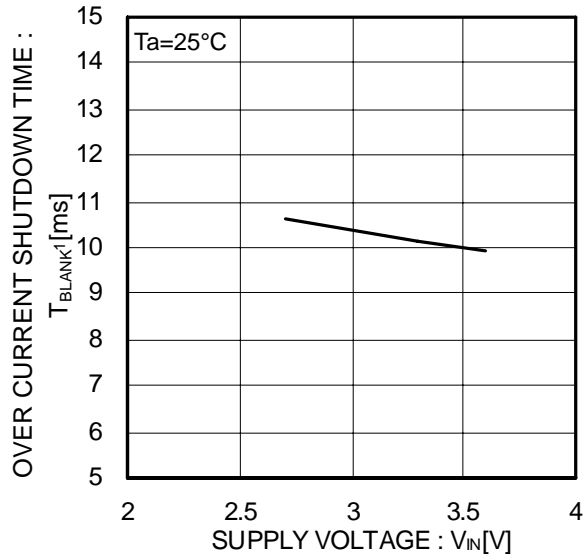

Figure 16. Over current shutdown time

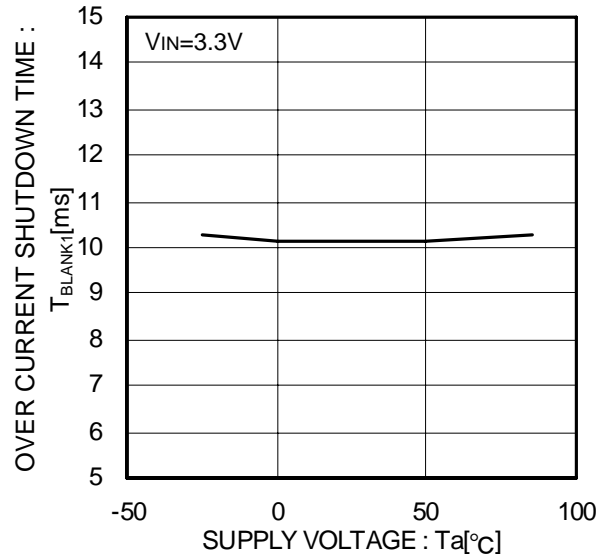

Figure 17. Over current shutdown time

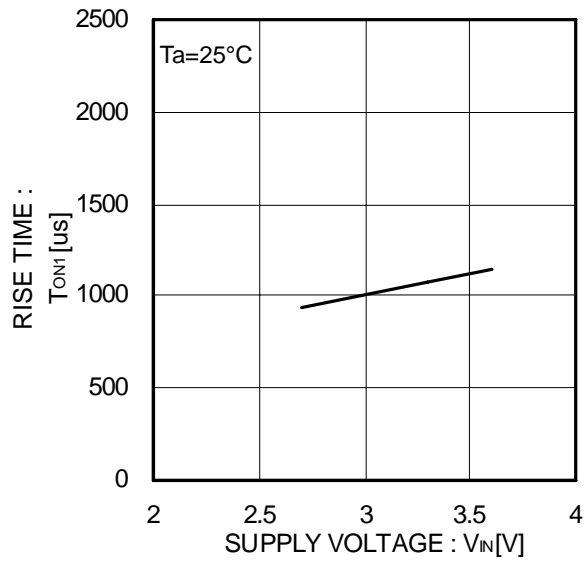

Figure 18. Output rise time

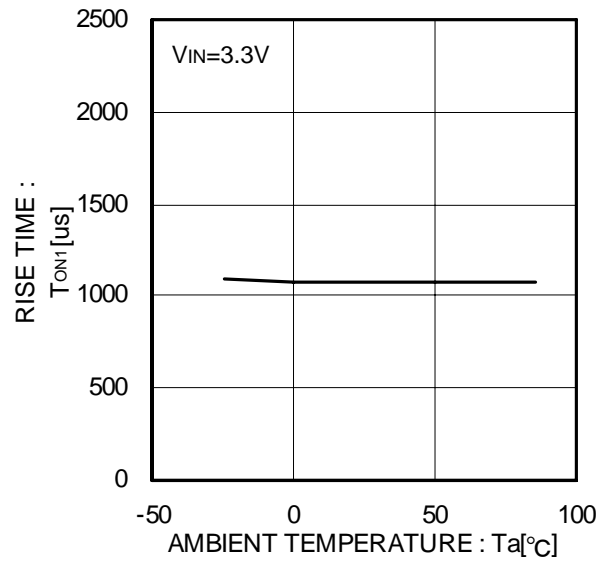

Figure 19. Output rise time

Typical Performance Curves - continued

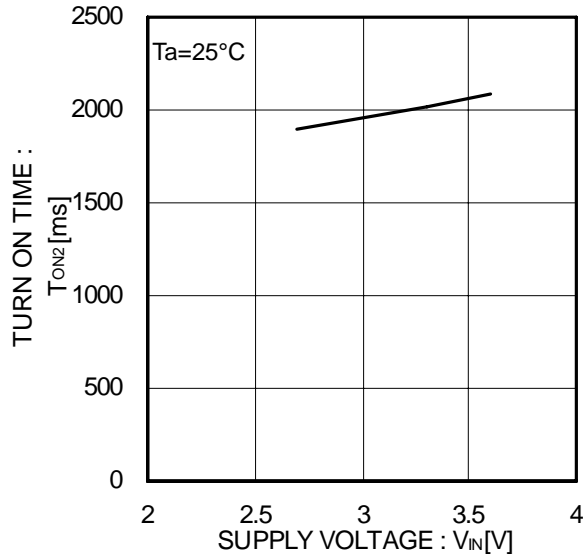

Figure 20. Output turn on time

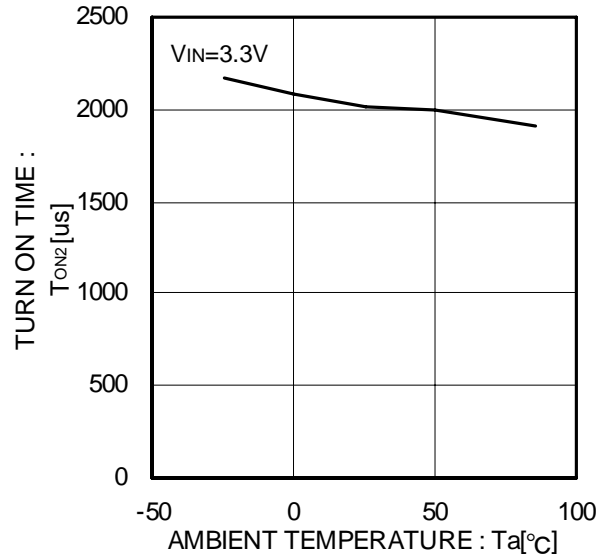

Figure 21. Output turn on time

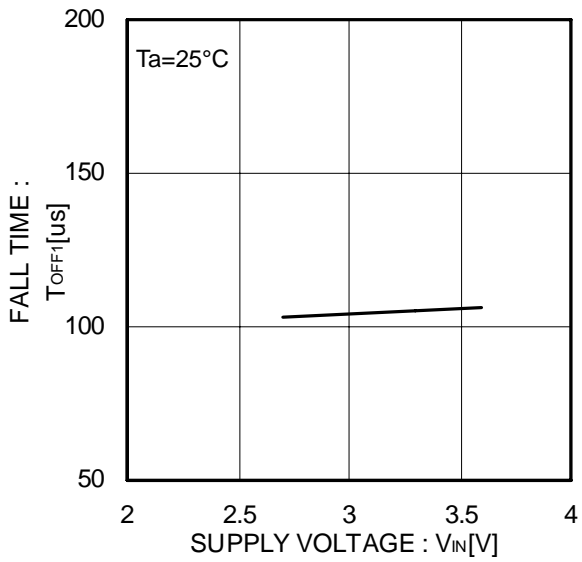

Figure 22. Output fall time

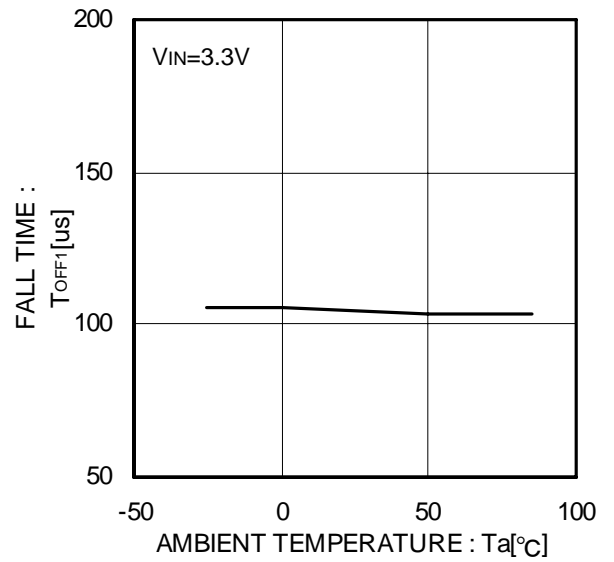

Figure 23. Output fall time

Typical Performance Curves - continued

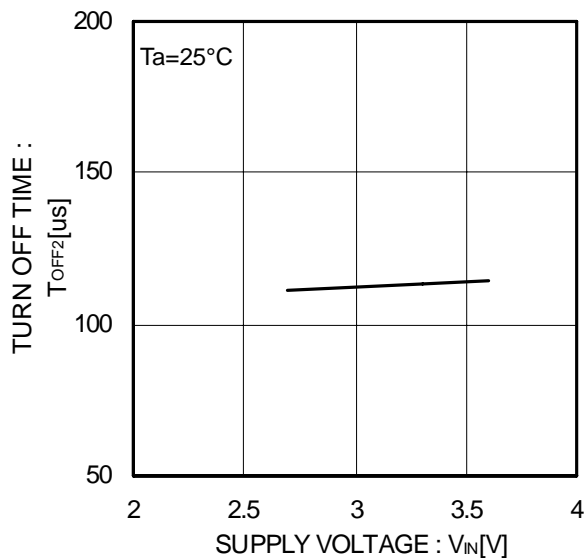

Figure 24. Output turn off time

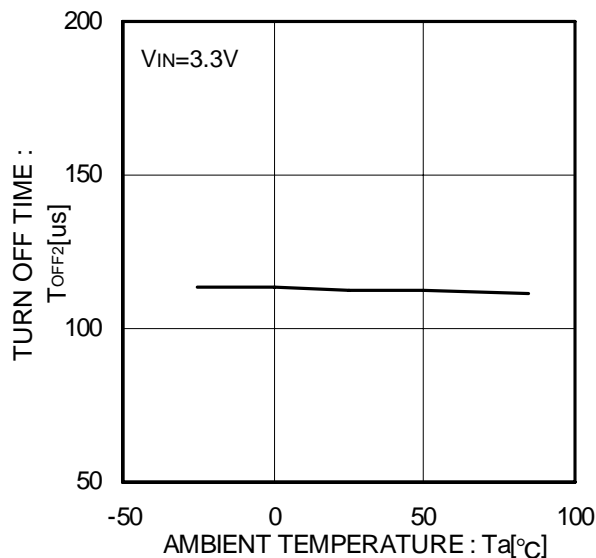

Figure 25. Output turn off time

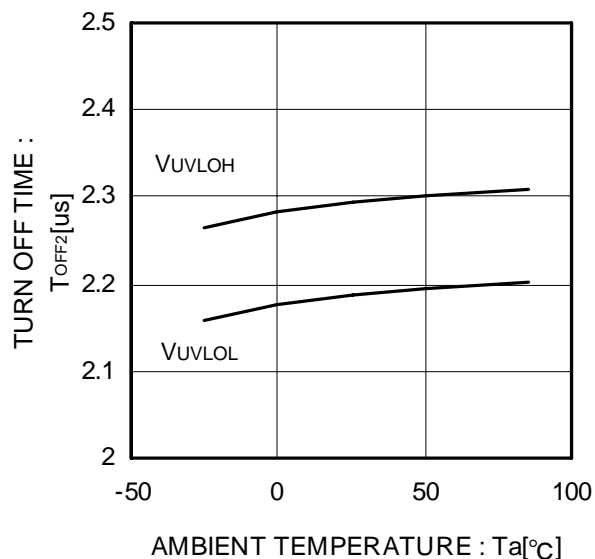

Figure 26. UVLO threshold voltage

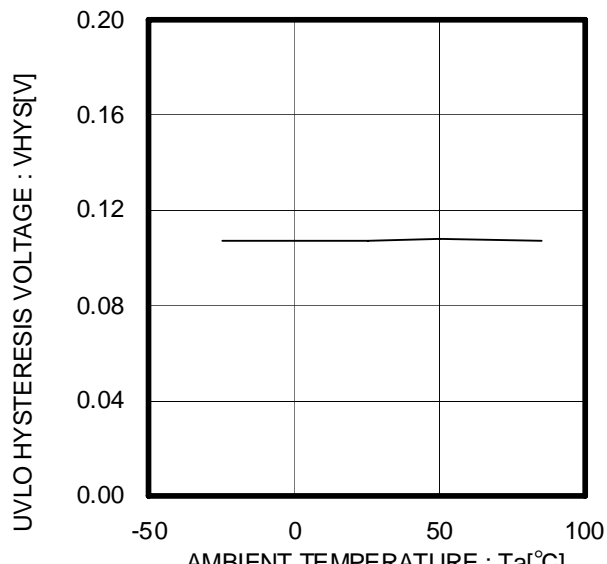

Figure 27. UVLO hysteresis voltage

Typical Wave Forms

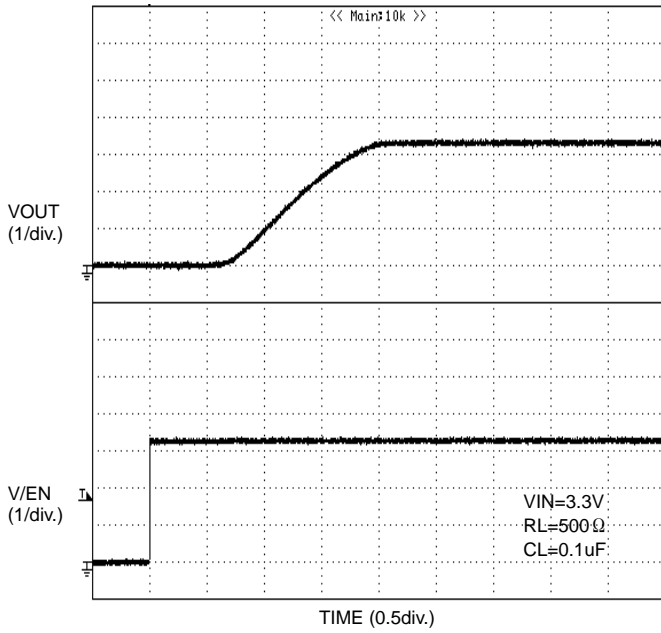

Figure 28. Output turn on response

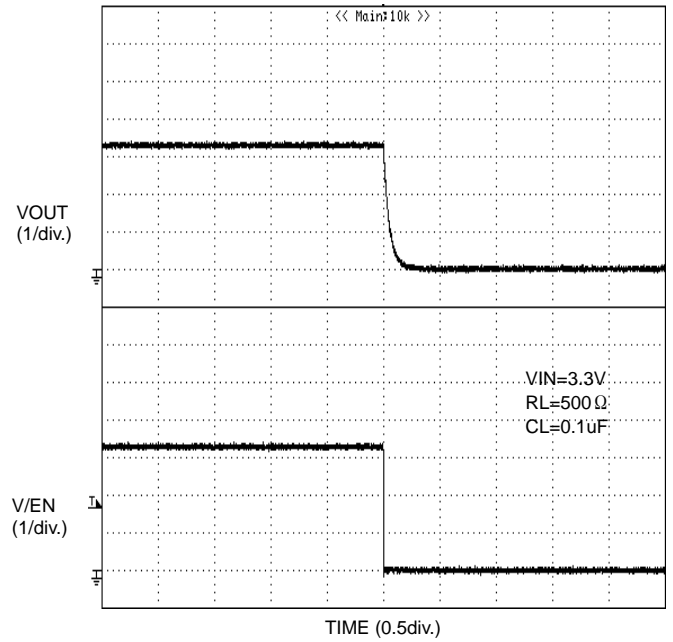

Figure 29. Output turn off response

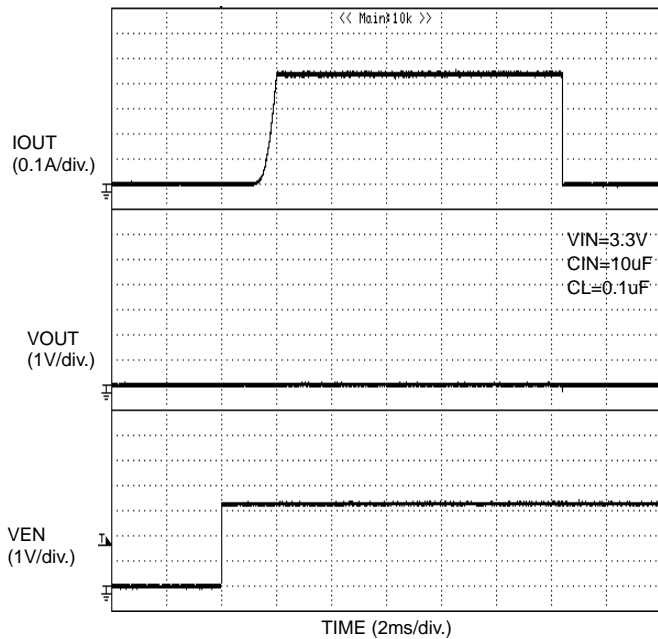

Figure 30. Current limit response
Enable into short circuit
(BD2202G)

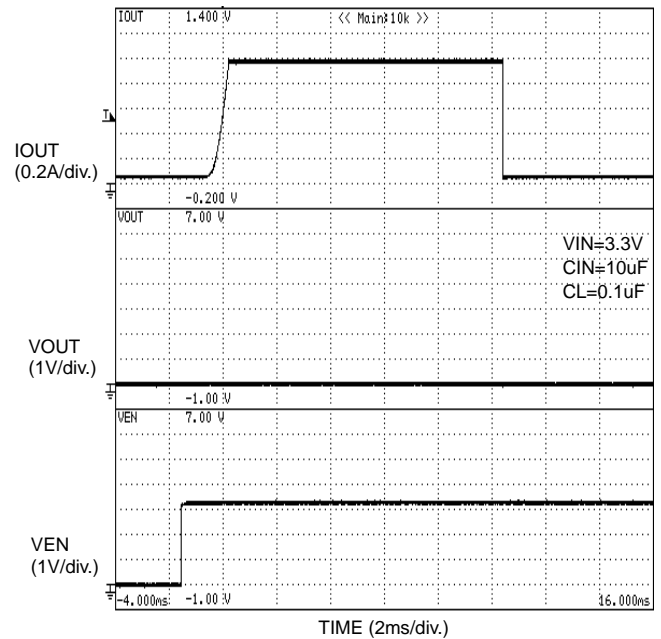

Figure 31. Current limit response
Enable into short circuit
(BD2206G)

Typical Wave Forms - continued

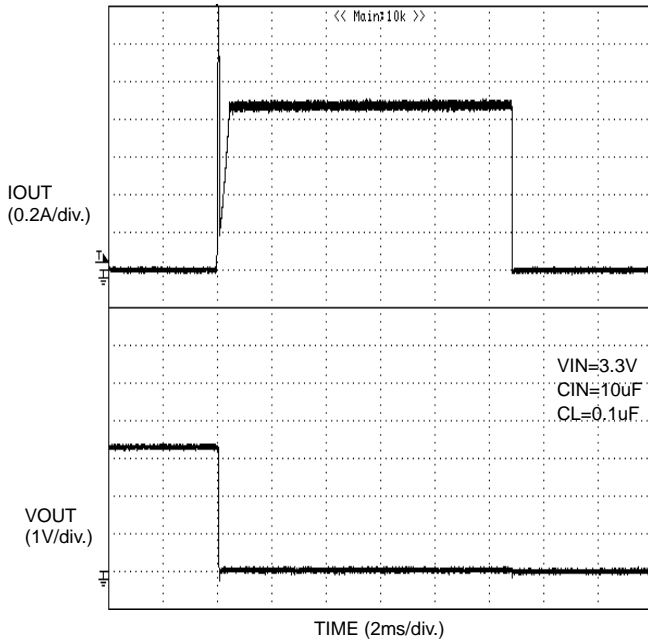

Figure 32. Current limit response
Output shorted to GND
(BD2202G)

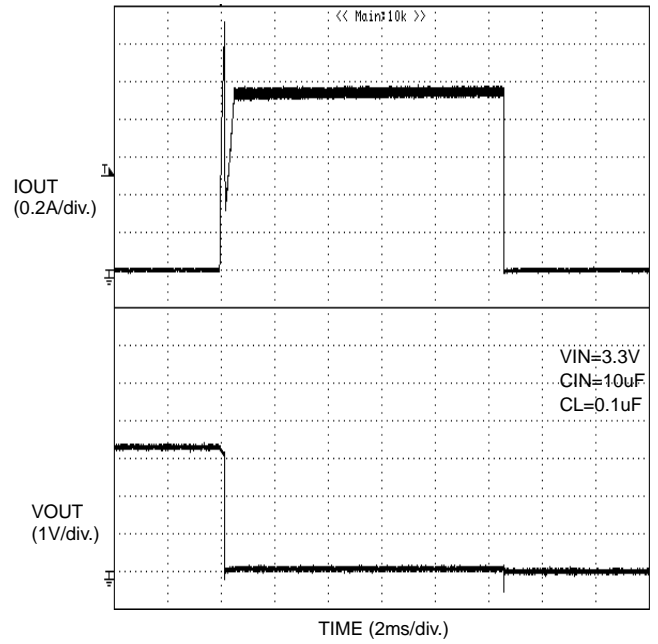

Figure 33. Current limit response
Output shorted to GND
(BD2206G)

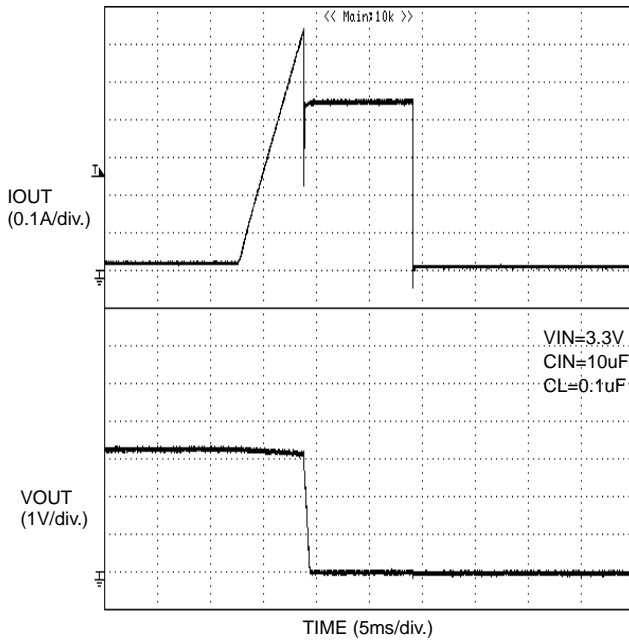

Figure 34. Current limit response
Ramped load (1A/10ms)
(BD2202G)

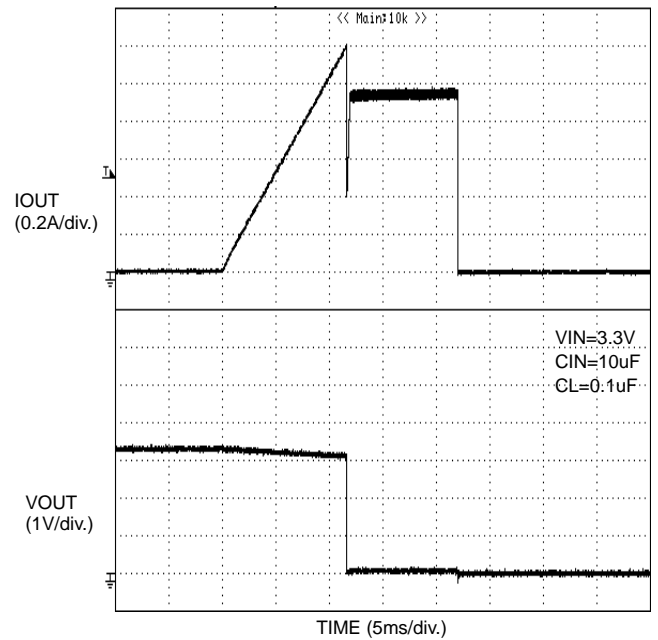

Figure 35. Current limit response
Ramped load (1A/10ms)
(BD2206G)

Typical Wave Forms - continued

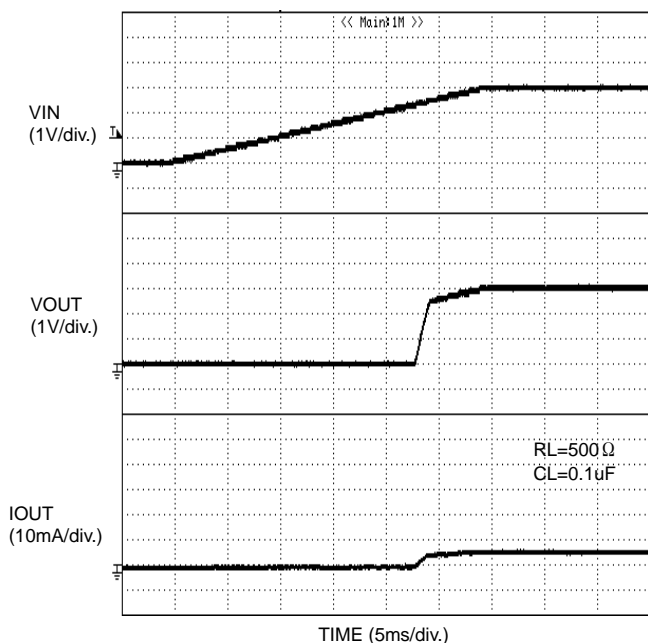

Figure 36. UVLO V_{IN} rising

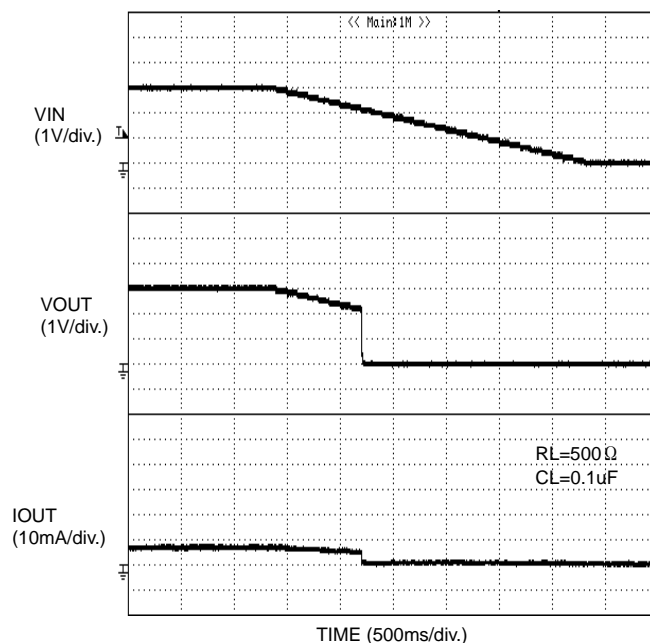
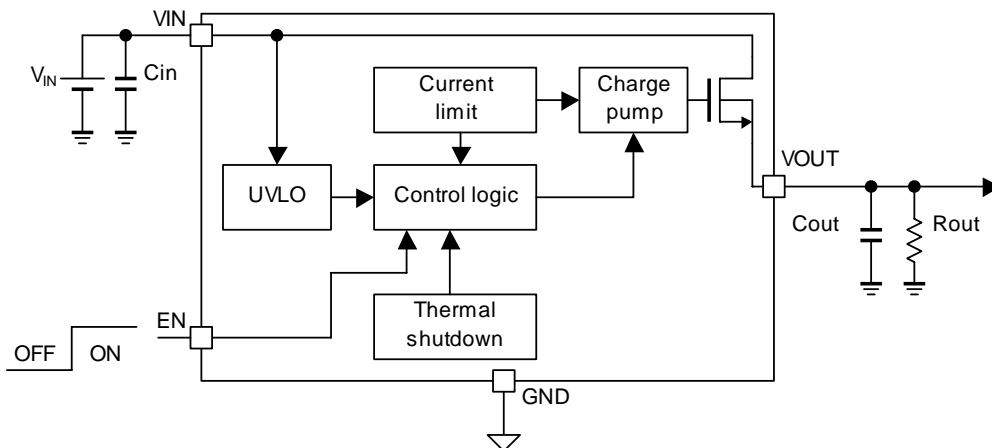

Figure 37. UVLO V_{IN} falling

Typical application circuit



Application Information

When excessive current flows due to output short-circuit or so, ringing occurs because of inductance between power source line to IC, and may cause bad influences on IC operations. In order to avoid this case, connect a bypass capacitor across IN terminal and GND terminal of IC. 1 μ F or higher is recommended.

This application circuit does not guarantee its operation.

When using the circuit with changes to the external circuit constants, make sure to leave an adequate margin for external components including AC/DC characteristics as well as dispersion of the IC.

Operation Description

BD2202G and BD2206G are high side switch ICs with over-current protection function. The operating voltage range is from 2.7V to 3.6V and the current limit value is set to 400mA and 1A respectively.

When an over-current condition lasts longer than its over-current shutdown time, the switch turns OFF. The OFF switch is set to latch mode. The switch set to latch mode returns to normal by toggling EN pin from High to Low to High.

1. Switch On/Off control

VIN terminal and VOUT terminal are connected to the drain and the source of switch MOSFET respectively. And the VIN terminal is used also as power source input to internal control circuit.

When the switch is turned on from EN control input, VIN and VOUT are connected by a 150mΩ switch. In normal condition, the switch is bidirectional. Therefore, when the voltage of VOUT is higher than VIN the current flows from VOUT to VIN.

In the switch MOSFET, there is a parasitic diode (body diode) between drain and source. So, even when the switch is off, when voltage of VOUT is higher than VIN, the current flows through the body diode from VOUT to VIN.

2. Over current detection (OCD)

The over current detection circuit limits current flowing in switch MOSFET when it exceeds its limit threshold. There are three types of responses against over current. The over current detection circuit is in operation when the power switch is ON (when EN signal is active).

2-1 When the switch is turned on while the output is in short-circuit status

When the switch is turned on while the output is in short-circuit status, the switch goes into current limit status immediately.

2-2 When the output short-circuits while the switch is on

When the output short-circuits or high-current load is connected while the switch is on, very large current flows until the over current limit circuit reacts. When the current detection and limit circuit works, current limitation is carried out.

2-3 When the output current increases gradually

When the output current increases gradually, current limitation does not work until the output current exceeds the over current detection value. When it exceeds the detection value, current limitation is carried out.

3. Over current shutdown

When the over current detection circuit detects an over current, TBLANK timer starts working. When the over current condition disappears before TBLANK2 stage, TBLANK timer is reset. When the over current condition progresses to more than TBLANK1, the switch is shut off. The OFF switch is set to latch off mode. The latch is reset when EN terminal is toggled or when UVLO is detected.

4. Under voltage lockout (UVLO)

UVLO keeps the power switch off until VIN voltage exceeds 2.3V (Typ.). Moreover, from a power switch ON situation, if VIN voltage drops to 2.2V (Typ.), the power switch is set to OFF. UVLO has a 100mV hysteresis. The under voltage lock out circuit is in operation when power switch is ON (when EN signal is active).

5. Thermal shutdown

When the chip temperature increases to 160°C (Typ.), the thermal shut down circuit works and the power switch is turned OFF. When the chip temperature falls to 140°C (Typ.), the power switch output returns to normal. This operation will repeat itself until the causes of the chip temperature rise are removed or until the power switch output is turned off.

The thermal shutdown circuit is in operation when the power switch is ON (when EN signal is active).

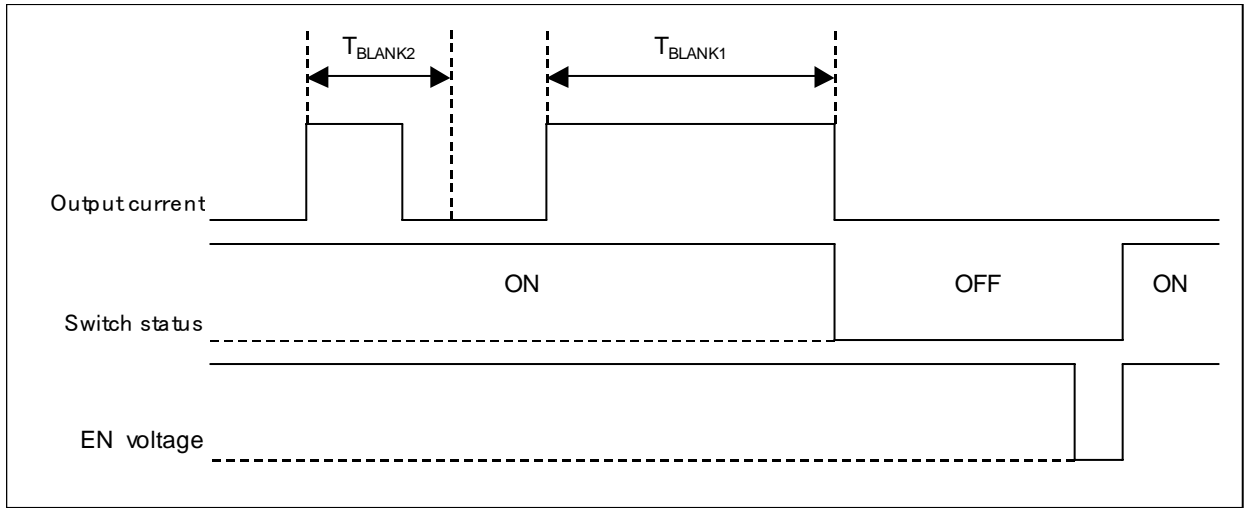

Figure 38. Over-current detection, shutdown operation (return with EN input)

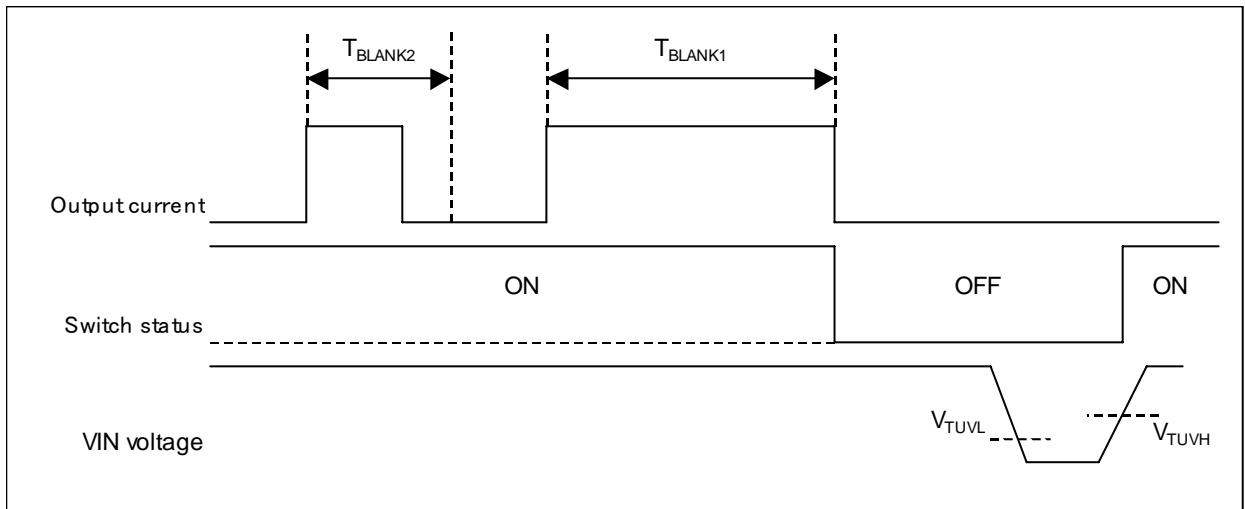

Figure 39. Over-current detection, shutdown operation (return with UVLO operation)

Power Dissipation
(SSOP5)

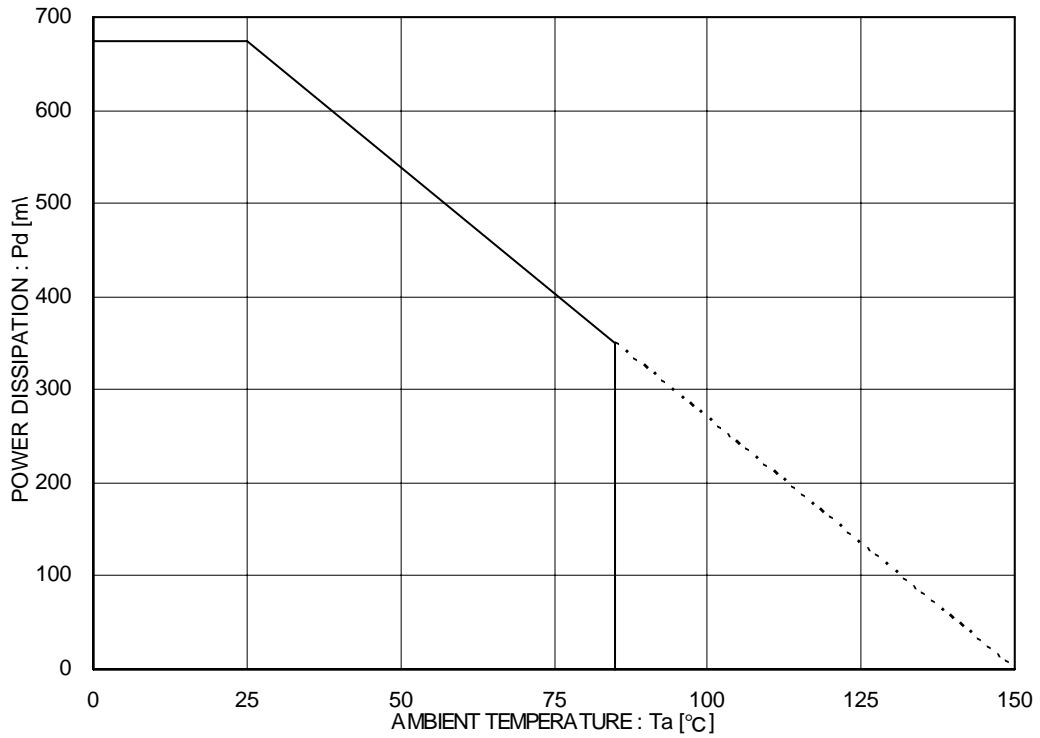

Figure 40. Power dissipation curve (Pd-Ta Curve)

I/O Equivalence Circuit

Pin Name	Pin Number	Equivalence circuits
EN	3	
VOUT	5	

Operational Notes

(1) Absolute Maximum Ratings

Operating the IC over the absolute maximum ratings may damage the IC. The damage can either be a short circuit between pins or an open circuit between pins. Therefore, it is important to consider circuit protection measures, such as adding a fuse, in case the IC is operated over the absolute maximum ratings.

(2) Recommended Operating Conditions

These conditions represent a range within which the expected characteristics of the IC can be approximately obtained. The electrical characteristics are guaranteed under the conditions of each parameter.

(3) Reverse Connection of Power Supply

Connecting the power supply in reverse polarity can damage the IC. Take precautions against reverse polarity when connecting the power supply, such as mounting an external diode between the power supply and the IC's power supply terminals.

(4) Power Supply Lines

Design the PCB layout pattern to provide low impedance ground and supply lines. Separate the ground and supply lines of the digital and analog blocks to prevent noise in the ground and supply lines of the digital block from affecting the analog block. Furthermore, connect a capacitor to ground at all power supply pins. Consider the effect of temperature and aging on the capacitance value when using electrolytic capacitors.

(5) Ground voltage

The voltage of the ground pin must be the lowest voltage of all pins of the IC at all operating conditions. Ensure that no pins are at a voltage below the ground pin at any time, even during transient condition.

(6) Short between Pins and Mounting Errors

Be careful when mounting the IC on printed circuit boards. The IC may be damaged if it is mounted in a wrong orientation or if pins are shorted together. Short circuit may be caused by conductive particles caught between the pins.

(7) Operation under Strong Electromagnetic Field

Operating the IC in the presence of a strong electromagnetic field may cause the IC to malfunction.

(8) Testing on Application Boards

When testing the IC on an application board, connecting a capacitor directly to a low-impedance output pin may subject the IC to stress. Always discharge capacitors completely after each process or step. The IC's power supply should always be turned off completely before connecting or removing it from the test setup during the inspection process. To prevent damage from static discharge, ground the IC during assembly and use similar precautions during transport and storage.

(9) Regarding Input Pins of the IC

This monolithic IC contains P+ isolation and P substrate layers between adjacent elements in order to keep them isolated. P-N junctions are formed at the intersection of the P layers with the N layers of other elements, creating a parasitic diode or transistor. For example (refer to figure below):

When $GND > Pin A$ and $GND > Pin B$, the P-N junction operates as a parasitic diode.

When $GND > Pin B$, the P-N junction operates as a parasitic transistor.

Parasitic diodes inevitably occur in the structure of the IC. The operation of parasitic diodes can result in mutual interference among circuits, operational faults, or physical damage. Therefore, conditions that cause these diodes to operate, such as applying a voltage lower than the GND voltage to an input pin (and thus to the P substrate) should be avoided.

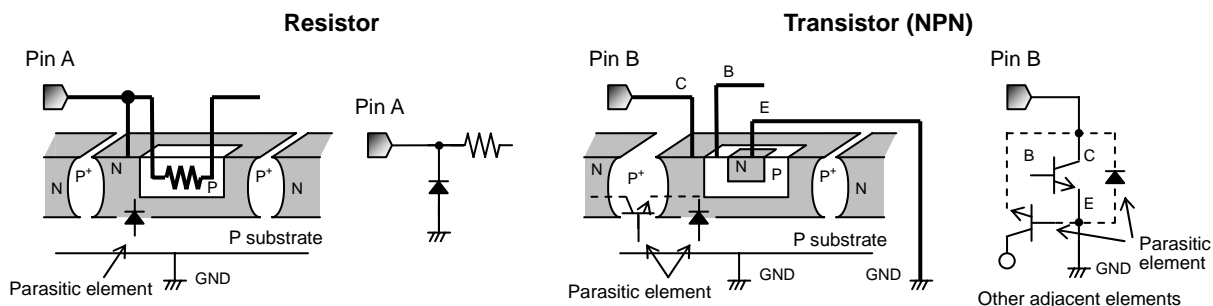

Figure 41. Example of monolithic IC structure

(10)GND Wiring Pattern

When using both small-signal and large-current GND traces, the two ground traces should be routed separately but connected to a single ground at the reference point of the application board to avoid fluctuations in the small-signal ground caused by large currents. Also ensure that the GND traces of external components do not cause variations on the GND voltage. The power supply and ground lines must be as short and thick as possible to reduce line impedance.

(11)External capacitor

When using a ceramic capacitor, determine the dielectric constant considering the change of capacitance with temperature and the decrease in nominal capacitance due to DC bias and others.

(12)Thermal Shutdown Circuit (TSD)

The IC incorporates a built-in thermal shutdown circuit, which is designed to turn off the IC when the internal temperature of the IC reaches a specified value. Do not continue to operate the IC after this function is activated. Do not use the IC in conditions where this function will always be activated.

(13)Thermal Consideration

Use a thermal design that allows for a sufficient margin by taking into account the permissible power dissipation (P_d) in actual operating conditions. Consider P_c that does not exceed P_d in actual operating conditions ($P_c \geq P_d$).

Package Power dissipation : $P_d (W) = (T_{jmax} - T_a) / \theta_{ja}$

Power dissipation : $P_c (W) = (V_{cc} - V_o) \times I_o + V_{cc} \times I_b$

(T_{jmax} : Maximum junction temperature=150°C, T_a : Peripheral temperature[°C],
 θ_{ja} : Thermal resistance of package-ambience[°C/W], P_d : Package Power dissipation [W],
 P_c : Power dissipation [W], V_{cc} : Input Voltage, V_o : Output Voltage, I_o : Load, I_b : Bias Current)

Ordering Information

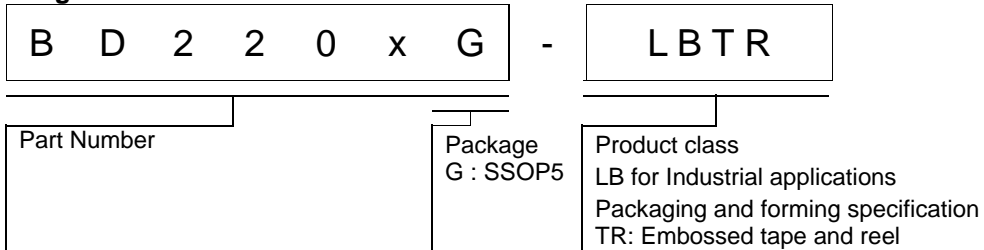

Marking Diagram

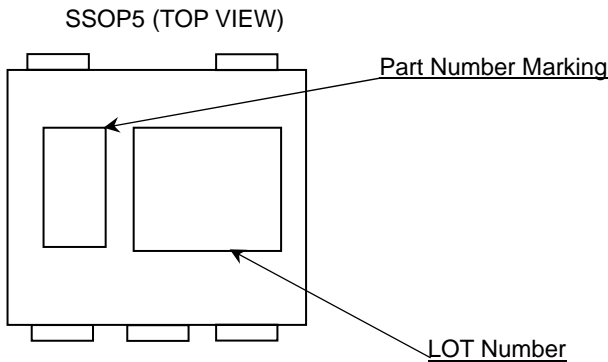

Part Number	Part Number Marking
BD2202G	AN
BD2206G	AR

Physical Dimension Tape and Reel Information

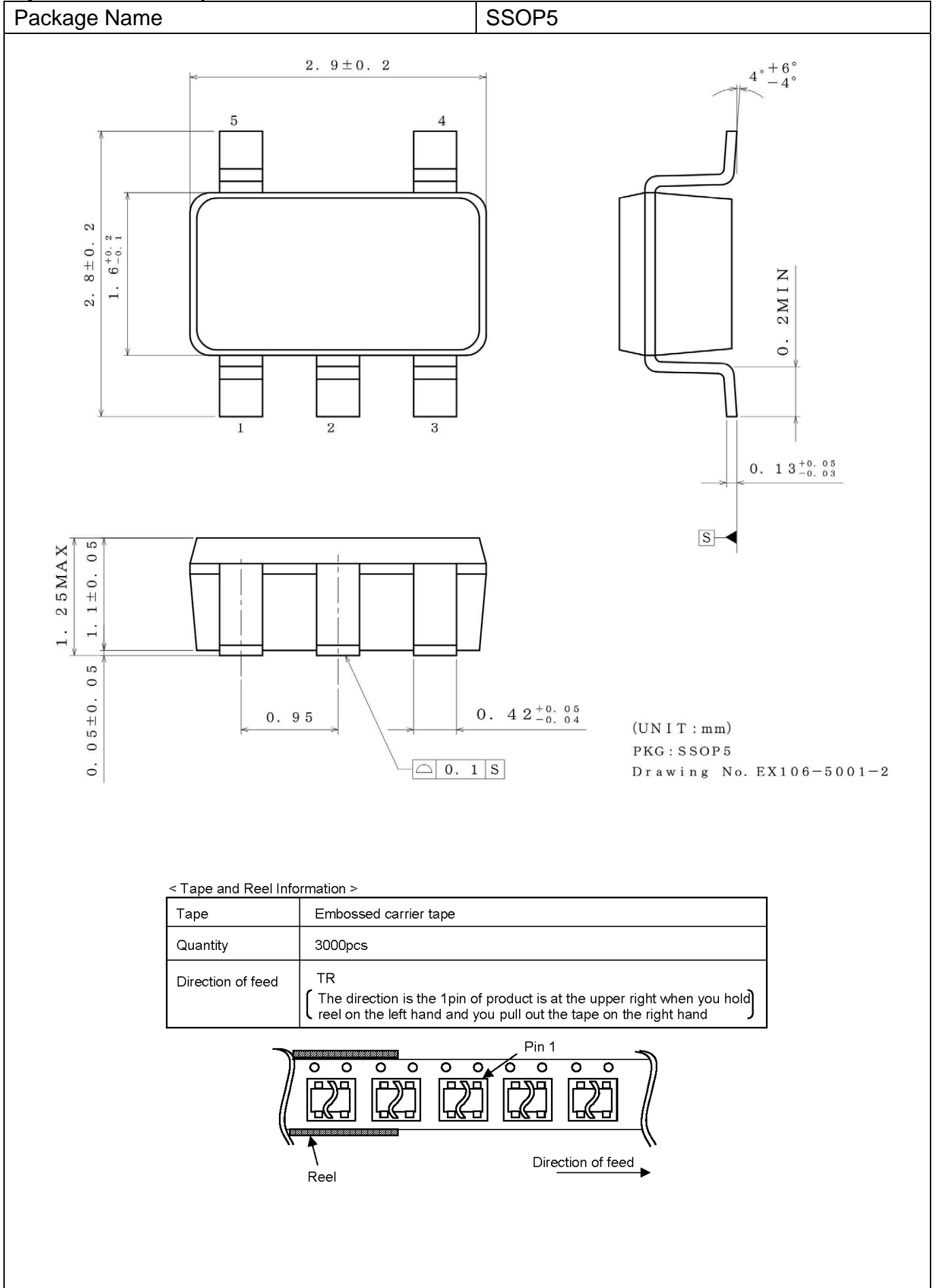

Revision History

Date	Revision	Changes
13.Mar.2012	001	New Release
21.Feb.2014	002	Delete sentence "and log life cycle" in General Description and Futures (page 1). Change "Industrial Applications" to "Industrial Equipment" in Applications (page 1). Applied new style ("title", "Ordering Information" and "Physical Dimension Tape and Reel Information").

Notice

Precaution on using ROHM Products

1. If you intend to use our Products in devices requiring extremely high reliability (such as medical equipment ^(Note 1), aircraft/spacecraft, nuclear power controllers, etc.) and whose malfunction or failure may cause loss of human life, bodily injury or serious damage to property ("Specific Applications"), please consult with the ROHM sales representative in advance. Unless otherwise agreed in writing by ROHM in advance, ROHM shall not be in any way responsible or liable for any damages, expenses or losses incurred by you or third parties arising from the use of any ROHM's Products for Specific Applications.

(Note1) Medical Equipment Classification of the Specific Applications

JAPAN	USA	EU	CHINA
CLASS III	CLASS III	CLASS II b	CLASS III
CLASS IV		CLASS III	

2. ROHM designs and manufactures its Products subject to strict quality control system. However, semiconductor products can fail or malfunction at a certain rate. Please be sure to implement, at your own responsibilities, adequate safety measures including but not limited to fail-safe design against the physical injury, damage to any property, which a failure or malfunction of our Products may cause. The following are examples of safety measures:
 - [a] Installation of protection circuits or other protective devices to improve system safety
 - [b] Installation of redundant circuits to reduce the impact of single or multiple circuit failure
3. Our Products are not designed under any special or extraordinary environments or conditions, as exemplified below. Accordingly, ROHM shall not be in any way responsible or liable for any damages, expenses or losses arising from the use of any ROHM's Products under any special or extraordinary environments or conditions. If you intend to use our Products under any special or extraordinary environments or conditions (as exemplified below), your independent verification and confirmation of product performance, reliability, etc, prior to use, must be necessary:
 - [a] Use of our Products in any types of liquid, including water, oils, chemicals, and organic solvents
 - [b] Use of our Products outdoors or in places where the Products are exposed to direct sunlight or dust
 - [c] Use of our Products in places where the Products are exposed to sea wind or corrosive gases, including Cl₂, H₂S, NH₃, SO₂, and NO₂
 - [d] Use of our Products in places where the Products are exposed to static electricity or electromagnetic waves
 - [e] Use of our Products in proximity to heat-producing components, plastic cords, or other flammable items
 - [f] Sealing or coating our Products with resin or other coating materials
 - [g] Use of our Products without cleaning residue of flux (even if you use no-clean type fluxes, cleaning residue of flux is recommended); or Washing our Products by using water or water-soluble cleaning agents for cleaning residue after soldering
 - [h] Use of the Products in places subject to dew condensation
4. The Products are not subject to radiation-proof design.
5. Please verify and confirm characteristics of the final or mounted products in using the Products.
6. In particular, if a transient load (a large amount of load applied in a short period of time, such as pulse. is applied, confirmation of performance characteristics after on-board mounting is strongly recommended. Avoid applying power exceeding normal rated power; exceeding the power rating under steady-state loading condition may negatively affect product performance and reliability.
7. De-rate Power Dissipation (Pd) depending on Ambient temperature (Ta). When used in sealed area, confirm the actual ambient temperature.
8. Confirm that operation temperature is within the specified range described in the product specification.
9. ROHM shall not be in any way responsible or liable for failure induced under deviant condition from what is defined in this document.

Precaution for Mounting / Circuit board design

1. When a highly active halogenous (chlorine, bromine, etc.) flux is used, the residue of flux may negatively affect product performance and reliability.
2. In principle, the reflow soldering method must be used; if flow soldering method is preferred, please consult with the ROHM representative in advance.

For details, please refer to ROHM Mounting specification

Precautions Regarding Application Examples and External Circuits

1. If change is made to the constant of an external circuit, please allow a sufficient margin considering variations of the characteristics of the Products and external components, including transient characteristics, as well as static characteristics.
2. You agree that application notes, reference designs, and associated data and information contained in this document are presented only as guidance for Products use. Therefore, in case you use such information, you are solely responsible for it and you must exercise your own independent verification and judgment in the use of such information contained in this document. ROHM shall not be in any way responsible or liable for any damages, expenses or losses incurred by you or third parties arising from the use of such information.

Precaution for Electrostatic

This Product is electrostatic sensitive product, which may be damaged due to electrostatic discharge. Please take proper caution in your manufacturing process and storage so that voltage exceeding the Products maximum rating will not be applied to Products. Please take special care under dry condition (e.g. Grounding of human body / equipment / solder iron, isolation from charged objects, setting of Ionizer, friction prevention and temperature / humidity control).

Precaution for Storage / Transportation

1. Product performance and soldered connections may deteriorate if the Products are stored in the places where:
 - [a] the Products are exposed to sea winds or corrosive gases, including Cl₂, H₂S, NH₃, SO₂, and NO₂
 - [b] the temperature or humidity exceeds those recommended by ROHM
 - [c] the Products are exposed to direct sunshine or condensation
 - [d] the Products are exposed to high Electrostatic
2. Even under ROHM recommended storage condition, solderability of products out of recommended storage time period may be degraded. It is strongly recommended to confirm solderability before using Products of which storage time is exceeding the recommended storage time period.
3. Store / transport cartons in the correct direction, which is indicated on a carton with a symbol. Otherwise bent leads may occur due to excessive stress applied when dropping of a carton.
4. Use Products within the specified time after opening a humidity barrier bag. Baking is required before using Products of which storage time is exceeding the recommended storage time period.

Precaution for Product Label

QR code printed on ROHM Products label is for ROHM's internal use only.

Precaution for Disposition

When disposing Products please dispose them properly using an authorized industry waste company.

Precaution for Foreign Exchange and Foreign Trade act

Since our Products might fall under controlled goods prescribed by the applicable foreign exchange and foreign trade act, please consult with ROHM representative in case of export.

Precaution Regarding Intellectual Property Rights

1. All information and data including but not limited to application example contained in this document is for reference only. ROHM does not warrant that foregoing information or data will not infringe any intellectual property rights or any other rights of any third party regarding such information or data. ROHM shall not be in any way responsible or liable for infringement of any intellectual property rights or other damages arising from use of such information or data.:
2. No license, expressly or implied, is granted hereby under any intellectual property rights or other rights of ROHM or any third parties with respect to the information contained in this document.

Other Precaution

1. This document may not be reprinted or reproduced, in whole or in part, without prior written consent of ROHM.
2. The Products may not be disassembled, converted, modified, reproduced or otherwise changed without prior written consent of ROHM.
3. In no event shall you use in any way whatsoever the Products and the related technical information contained in the Products or this document for any military purposes, including but not limited to, the development of mass-destruction weapons.
4. The proper names of companies or products described in this document are trademarks or registered trademarks of ROHM, its affiliated companies or third parties.

General Precaution

1. Before you use our Products, you are requested to carefully read this document and fully understand its contents. ROHM shall not be in any way responsible or liable for failure, malfunction or accident arising from the use of any ROHM's Products against warning, caution or note contained in this document.
2. All information contained in this document is current as of the issuing date and subject to change without any prior notice. Before purchasing or using ROHM's Products, please confirm the latest information with a ROHM sales representative.
3. The information contained in this document is provided on an "as is" basis and ROHM does not warrant that all information contained in this document is accurate and/or error-free. ROHM shall not be in any way responsible or liable for any damages, expenses or losses incurred by you or third parties resulting from inaccuracy or errors of or concerning such information.

Mouser Electronics

Authorized Distributor

Click to View Pricing, Inventory, Delivery & Lifecycle Information:

[ROHM Semiconductor:](#)

[BD2206G-LBTR](#) [BD2202G-LBTR](#)

Данный компонент на территории Российской Федерации

Вы можете приобрести в компании MosChip.

Для оперативного оформления запроса Вам необходимо перейти по данной ссылке:

<http://moschip.ru/get-element>

Вы можете разместить у нас заказ для любого Вашего проекта, будь то серийное производство или разработка единичного прибора.

В нашем ассортименте представлены ведущие мировые производители активных и пассивных электронных компонентов.

Нашей специализацией является поставка электронной компонентной базы двойного назначения, продукции таких производителей как XILINX, Intel (ex.ALTERA), Vicor, Microchip, Texas Instruments, Analog Devices, Mini-Circuits, Amphenol, Glenair.

Сотрудничество с глобальными дистрибьюторами электронных компонентов, предоставляет возможность заказывать и получать с международных складов практически любой перечень компонентов в оптимальные для Вас сроки.

На всех этапах разработки и производства наши партнеры могут получить квалифицированную поддержку опытных инженеров.

Система менеджмента качества компании отвечает требованиям в соответствии с ГОСТ Р ИСО 9001, ГОСТ РВ 0015-002 и ЭС РД 009

Офис по работе с юридическими лицами:

105318, г.Москва, ул.Щербаковская д.3, офис 1107, 1118, ДЦ «Щербаковский»

Телефон: +7 495 668-12-70 (многоканальный)

Факс: +7 495 668-12-70 (доб.304)

E-mail: info@moschip.ru

Skype отдела продаж:

moschip.ru

moschip.ru_4

moschip.ru_6

moschip.ru_9