

DESCRIPTION

Demonstration circuit 549 is a monolithic step-down DC/DC switching converter using the LT3431. The board is optimized for 5V output at up to 2A load current for a steady state input voltage range of 7.5V to 20V. The LT3431 is capable of withstanding input transients to 60V and runs at 500kHz with steady state input voltages that require duty cycles between 25% and 75%. For duty cycles below 25% the part may pulse skip to effectively average the lower duty cycle and still provide minimum on-time switch cycles. With its wide input voltage range, 3A internal power switch, high 500kHz switching frequency and thermally enhanced package, the LT3431 is a very versatile and powerful IC for DC/DC converters that require compact size, high efficiency and tolerance to high input voltage transients.

The LT3431 500kHz switching frequency allows all of the components to be small, surface mount devices. Synchronization with an external clock of up to 700kHz is possible. The current-mode control topology creates fast transient response and good loop stability with a minimum number of external compensation components. In particular, the current-mode architecture allows the use of ceramic input and output capacitors for increased reliability, extremely low output ripple voltage and small component size. The low resistance internal power switch (0.1Ω) maintains high efficiencies of up to 87%. The

SHDN pin can be used to program undervoltage lockout or place the part in micropower shutdown, reducing supply current to $30\mu\text{A}$ by driving the pin low.

The LT3431 datasheet gives a complete description of the part, operation and applications information. The datasheet must be read in conjunction with this Quick Start Guide for demonstration circuit 549. In particular, the datasheet section on "Thermal Calculations" is important for estimating whether a given application's combination of input voltage, load current and frequency will cause ~~the~~ LT3431 to exceed its absolute maximum rated junction temperature. The part is assembled in a small 16-pin thermally enhanced package with exposed pad where proper board layout is essential for maximum thermal performance. See the datasheet section "Layout Considerations".

NOTE: Do not hot-plug the input voltage terminal V_{IN} . The absolute maximum voltage on V_{IN} is 60V and hot-plugging a power supply through wire leads to the demonstration card can cause the voltage on the extremely low-ESR ceramic input capacitor to ring to twice its DC value. This is due to high currents instantaneously generated in the inductive supply leads from an input voltage step on the low-ESR ceramic input capacitor. An over-voltage can result if care is not taken to ensure that this does not happen. A bulky higher-ESR capacitor, and an additional inductive

QUICK START GUIDE FOR DEMONSTRATION CIRCUIT 549

2A, 500KHZ HIGH VOLTAGE BUCK CONVERTER

filter between the bulk capacitor and the input capacitor can be added to the circuit to dampen hot-plug transient ringing. See *Application Note 88* for more details.

Design files for this circuit board are available. Call the LTC factory.

Table 1. Typical Performance Summary

PARAMETER	CONDITION	VALUE
Steady State Input Voltage Range	$V_{OUT} = 5V, I_{OUT} \leq 2A, T_A = 25^\circ C$	7.5-20V
Maximum Transient Input Voltage		60V
V_{OUT}	$I_{OUT} \leq 2A$	5V \pm 3%
Maximum Output Current		2A
Typical Switching Frequency		500kHz
Typical Efficiency	$V_{IN} = 12V, V_{OUT} = 5V, I_{OUT} = 2A$	83%

QUICK START GUIDE FOR DEMONSTRATION CIRCUIT 549 2A, 500KHZ HIGH VOLTAGE BUCK CONVERTER

QUICK START PROCEDURE

Demonstration circuit 549 is easy to set up to evaluate the performance of the LT3431. Refer to Figure 1 for proper measurement equipment setup and follow the procedure below:

NOTE: Make sure that the input voltage does not exceed 60V.

NOTE: The synchronization and shutdown functions are optional and their pins

can be left floating (disconnected) if their functions are not being used.

1. Connect the power supply, load, and meters shown in Figure 1.
2. After all connections are made, turn on input power and verify that the output voltage is 5.0V.

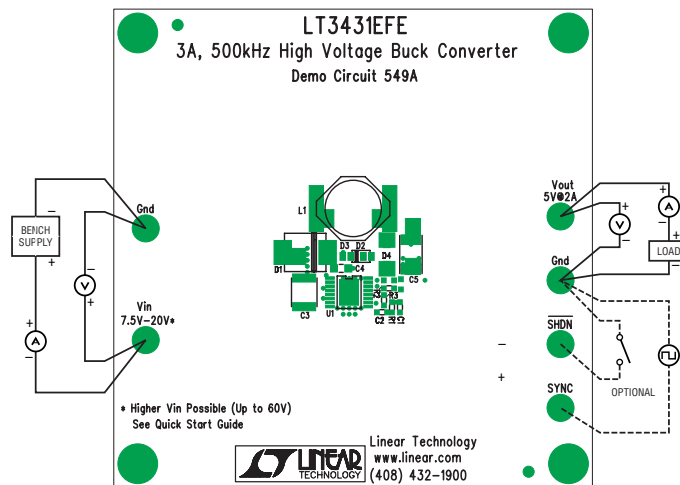

Figure 1. Proper Measurement Equipment Setup

CUSTOMIZING THE DEMONSTRATION CIRCUIT

CUSTOMIZING THE OUTPUT VOLTAGE

The components assembled on the board are optimized for a wide input voltage range and a 5V output. The feedback resistors (R2, R3) can be changed to adjust the output voltage according to the following equation:

$$V_{OUT} = 1.22 (1 + R2/R3)$$

The Thevenin resistance seen at the FB pin should be less than 3.8k to

maximize frequency foldback during start-up and short-circuit.

For output voltages below 3V, the boost diode should be moved from D2 to D3 to provide the minimum boost voltage required for the internal power switch. Make sure that the boost capacitor (C4) has a voltage rating greater than the output voltage for applications where the boost diode is placed in D2 and greater

QUICK START GUIDE FOR DEMONSTRATION CIRCUIT 549

2A, 500KHZ HIGH VOLTAGE BUCK CONVERTER

than the input voltage when the boost diode is placed in position D3.

For output voltages greater than 5V, the optional 'blocking' zener diode D4 can be used to reduce the boost voltage across C4 from the output voltage to some lower voltage between 3V and 5V. This diode transfers power dissipation from inside the IC to the discrete component outside the IC, allowing higher ambient temperature operation for the part. It is recommended that an SMAZ7V5 zener diode is used in D4 when $V_{OUT} = 12V$. To properly install D4, the small trace shorting the anode to the cathode of D4 on the board must be opened (an Exacto knife works well) before D4 is soldered to the board. In the 'Thermal Calculations' section of Applications Information in the datasheet, the boost power consumption in the IC must account for the zener blocking diode V_z , so the boost voltage changes from V_{OUT} to $(V_{OUT} - V_z)$.

COMPENSATION

Demonstration Circuit 549 has a frequency compensation network that is optimized for the ceramic output capacitor C5, the wide input voltage

range 7.5V to 20V, and 5V output. Improved loop bandwidth can be achieved for various output voltages, output capacitors, and input voltage ranges by adjusting R1, C1, and C2. Additional optional component locations for feedforward capacitor (C8) and resistor (R4 for short circuit feedback pin protection when feedforward capacitor is used) are located in parallel with R2. For more information, see the 'Frequency Compensation' section in the Applications Information in the datasheet, Application Notes 19 or Application Note 76.

SOFT START

When the ratio of the input voltage divided by the output voltage (plus the forward voltage of the catch diode) is greater than four

$$V_{IN}/(V_{OUT} + V_F) > 4$$

the soft start circuit made up of components C9, R5, R6, and Q1 should be used to control output voltage rise time and overshoot during startup. The soft start circuit is covered in detail in 'Buck Converter with Adjustable Soft Start' in the Applications Information in the datasheet.

QUICK START GUIDE FOR DEMONSTRATION CIRCUIT 549

2A, 500KHZ HIGH VOLTAGE BUCK CONVERTER

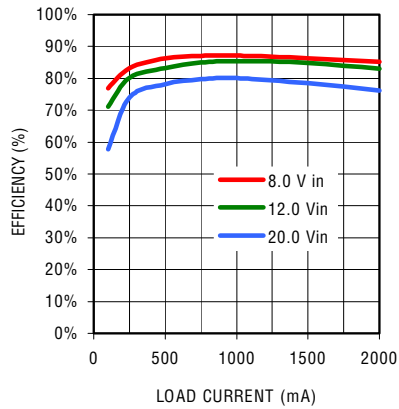

Figure 2. Efficiency

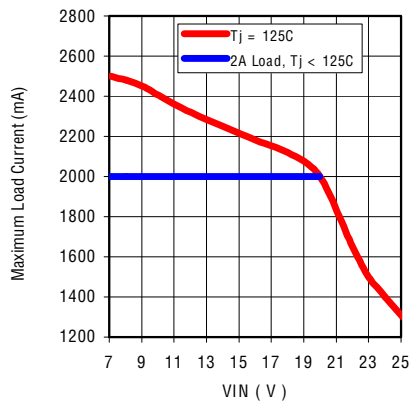
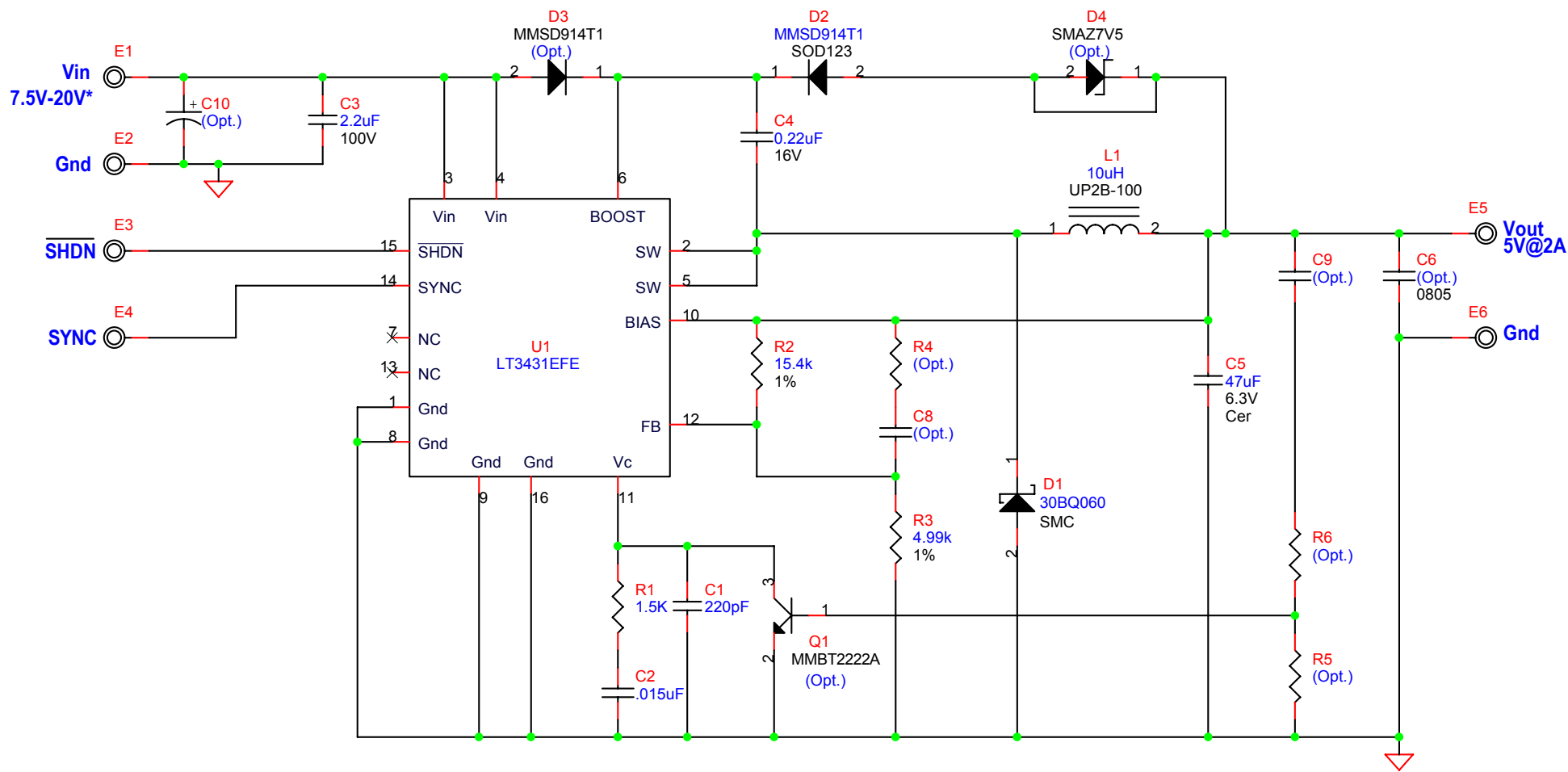

Figure 3. Maximum Load Current Capabilities
($T_A = 25^\circ\text{C}$)



NOTE: UNLESS OTHERWISE SPECIFIED

For All Optional Components On Boards:
 Q1,R5,R6,C9 Show Ref. Des. And Outline
 D3,D4 Show Ref. Des. With No Outline
 C6,C7,C8,C10,R4 Show No Ref. Des. And No Outline

* High Vin Possible (Up to 60V)
 With Thermal Constraints. See Quick Start Guide

LINEAR TECHNOLOGY CORPORATION

1630 McCARTHY BLVD.
 MILPITAS, CA 95035
 PHONE (408) 432-1900
 FAX (408) 434-0507

Title

3A, 500kHz High Voltage Buck Converter

Size

Document Number

DC549A

LT3431EFE

Rev

Date: Tuesday, September 03, 2002

Sheet 1 of 1

Item	Qty	Reference	Part Description	Manufacture / Part #
1	1	C1	CAP, NPO 220pF 25V	AVX, 06033A221KAT1A 0603
2	1	C2	CAP, X7R 0.015uF 50V	AVX, 06035C153KAT1A 0603
3	1	C3	CAP, Y5U 2.2uF 100V	UNITED CHEMI-CON, THCS50E2A225ZT
4	1	C4	CAP, X7R 0.22uF 16V	TAIYO YUDEN, EMK212BJ224MG 0805
5	1	C5	CAP, CER 47uF 6.3V	TDK, C4532X5R0J476M 1812
6	0	C6	CAP, 0805 (Opt.)	
7	0	C8,C9	CAP, 0603 (Opt.)	
8	0	C10	CAP, C-CASE (Opt.)	
9	1	D1	DIODE SCHOTTKY,3A, 60V,SMA	IR, 30BQ060 SMC
10	1	D2	DIODE, 200mA, 100V	DIODES INC. 1N4148W-7 SOD-123
11	0	D3	DIODE, (Opt.)	ON SEMI., MMSD914T1-7 SOD-123
12	0	D4	DIODE, (Opt.)	DIODES INC., SMAZ7V5 SMA
13	6	E1-E6	TP, TURRET, .094"	MILL-MAX, 2501-2
14	1	L1	INDUCTOR, SMT, 10uH, L-COIL-UP2B	COOPER ELECT. UP2B-100
15	0	L1	INDUCTOR, (Opt.)	SUMIDA, CDRH8D28
16	0	Q1	TRANS, (Opt.)	DIODES INC., MMBT2222A-7 SOT-23
17	1	R1	RES, 1.5K 1%, 0603	AAC, CR16-1501FM
18	1	R2	RES, 15.4k 1%, 0603	AAC, CR16-1542FM
19	1	R3	RES, 4.99k 1%, 0603	AAC, CR16-4991FM
20	0	R4,R5,R6	RES, (Opt.)	
21	1	U1	IC, LT3431EFE	LINEAR TECH., LT3431EFE TSSOPEF16
22	4	4 CORNERS	STANDOFF, NYLON HEX #4-40 x 1/4"	MICRO PLASTICS, #14HTSP101
23	4		SCREW, #4-40 x 1/4	ANY

Данный компонент на территории Российской Федерации

Вы можете приобрести в компании MosChip.

Для оперативного оформления запроса Вам необходимо перейти по данной ссылке:

<http://moschip.ru/get-element>

Вы можете разместить у нас заказ для любого Вашего проекта, будь то серийное производство или разработка единичного прибора.

В нашем ассортименте представлены ведущие мировые производители активных и пассивных электронных компонентов.

Нашей специализацией является поставка электронной компонентной базы двойного назначения, продукции таких производителей как XILINX, Intel (ex.ALTERA), Vicor, Microchip, Texas Instruments, Analog Devices, Mini-Circuits, Amphenol, Glenair.

Сотрудничество с глобальными дистрибьюторами электронных компонентов, предоставляет возможность заказывать и получать с международных складов практически любой перечень компонентов в оптимальные для Вас сроки.

На всех этапах разработки и производства наши партнеры могут получить квалифицированную поддержку опытных инженеров.

Система менеджмента качества компании отвечает требованиям в соответствии с ГОСТ Р ИСО 9001, ГОСТ РВ 0015-002 и ЭС РД 009

Офис по работе с юридическими лицами:

105318, г.Москва, ул.Щербаковская д.3, офис 1107, 1118, ДЦ «Щербаковский»

Телефон: +7 495 668-12-70 (многоканальный)

Факс: +7 495 668-12-70 (доб.304)

E-mail: info@moschip.ru

Skype отдела продаж:

moschip.ru

moschip.ru_4

moschip.ru_6

moschip.ru_9