

Interactive Catalog Replaces Catalog Pages

Honeywell Sensing and Control has replaced the PDF product catalog with the new **Interactive Catalog**. The **Interactive Catalog** is a power search tool that makes it easier to find product information. It includes more installation, application, and technical information than ever before.



**Click this icon to try the new
Interactive Catalog.**

Sensing and Control

Honeywell Inc.

11 West Spring Street

Freeport, Illinois 61032

Pressure Sensors

160PC Series

Low Pressure Differential, Gage, Vacuum Gage/Amplified

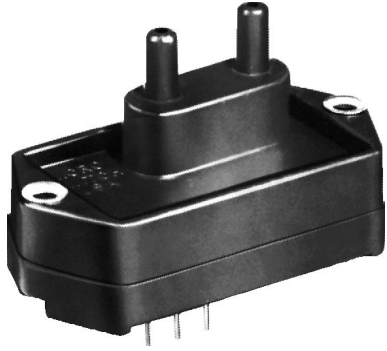

FEATURES

- Low pressure measurement
- PCB terminals on opposite side from the ports
- Fully signal conditioned

160PC SERIES PERFORMANCE CHARACTERISTICS at 8.0 ±0.01 VDC Excitation, 25°C (Exception 163PC at 10 ±0.01 VDC Excitation, 25°C)

	Min.	Typ.	Max.	Units
Excitation	6.00	8.00	16	VDC
Supply Current	---	8.00	20	mA
Current Sourcing Output	---	---	10	mA
Null Offset (161/162/164PC) *	0.95	1.00	1.05	V
Null Offset (163PC) **	3.45	3.50	3.55	V
Output at Full Pressure (161/162/164PC)	5.90	6.00	6.10	V
Output at Full Vacuum (163PC)	0.80	1.00	1.20	V
Span (161/162/164PC)	4.85	5.00	5.15	V
Span (163PC) **	---	5.00	---	V
Ratiometricity Error				
7 to 8 V or 8 to 9 V	---	±0.50	---	%Span
9 to 12 V	---	±2.00	---	
Stability over One Year	---	±0.50	---	%Span
Response Time	---	---	1.00	msec
Weight	---	28	---	grams
Short Circuit Protection	Output may be shorted indefinitely to ground			
Output Ripple	None, DC device			
Ground Reference	Supply and output are common			

*Positive (or negative) pressure measurement.

**Positive AND negative pressure measurement.

ENVIRONMENTAL SPECIFICATIONS

Operating Temperature	-40° to +85°C (-40° to +185°F)
Storage Temperature	-55° to +125°C (-67° to +257°F)
Compensated Temperature	-18° to +63°C (0° to +145°F)
Shock	MIL-STD-202, Method 213 (50 g, half sine, 6 msec)
Vibration	MIL-STD-202, Method 204 (10 to 2000 Hz at 10 g)
Media	P2 port Wetted materials; polyester housing, epoxy adhesive, silicon, borosilicate glass, and silicon-to-glass bond*
	P1 port Dry gases only

*Liquid media containing some highly ionic solutions could potentially neutralize the chip-to-glass tube bond.

Amplified

Low Pressure Differential, Gage, Vacuum Gage/Amplified

160PC SERIES ORDER GUIDE, VACUUM GAGE AND GAGE TYPE

Catalog Listing	Pressure Range "H ₂ O	Shift Null, Sensitivity, Combined**			Sensitivity V/"H ₂ O	Overpressure psi Max.	Linearity, B.F.S.L.		Repeatability & Hysteresis % Span Typ.
		25 to 5° 25 to 45°C	25 to -18° 25 to +63°C	25 to -40° 25 to 85°C			P2 > P1	P2 < P1	
		%Span							
		Max.	Max.	Max.			Max.	Max.	
161PC01D	0-27.68	---	±1.00	±2.00	0.18	5	---	±1.00	±0.15 Vacuum Gage
162PC01G	0-27.68	---	±1.00	±2.00	0.18	5	---	±1.00	±0.15 Gage

160PC SERIES ORDER GUIDE, DIFFERENTIAL TYPE

Catalog Listing	Pressure Range "H ₂ O	Shift Null, Sensitivity, Combined**			Sensitivity V/"H ₂ O	Overpressure psi Max.	Linearity, B.F.S.L.		Repeatability & Hysteresis % Span Typ.
		25 to 5° 25 to 45°C	25 to -18° 25 to +63°C	25 to -40° 25 to 85°C			P2 > P1	P2 < P1	
		%Span							
		Max.	Max.	Max.			Max.	Max.	
162PC01D	0-27.68	---	±1.00	±2.00	0.18	5	±2.00	---	±0.15
163PC01D36	±5	±1.00	---	---	0.50	5	±2.00	±1.00	±0.25
164PC01D37	0-10	±1.00	---	---	0.50	5	±2.00	---	±0.25
163PC01D75	±2.5	±1.25	---	---	1.00	5	±2.00	±1.00	±0.25
164PC01D76	0-5	±1.25	---	---	1.00	5	±2.00	---	±0.25

160PC SERIES ORDER GUIDE, DIFFERENTIAL TYPE @ 10 VDC ±0.01 EXCITATION, 25°C

Catalog Listing	Pressure Range cmH ₂ O	Shift Null, Sensitivity, Combined**			Sensitivity V/cmH ₂ O	Overpressure cmH ₂ O Max.	Linearity, B.F.S.L.		Repeatability & Hysteresis % Span Typ.
		25 to 5° 25 to 45°C	25 to -18° 25 to +63°C	25 to -40° 25 to 85°C			P2 > P1	P2 < P1	
		%Span							
		Max.	Max.	Max.			Max.	Max.	
163PC01D48	-20 to +120	±0.75*	---	---	0.36	350	±1.5	---	±0.15

*Null shift. Span shift is ±1.00/Span

**% Span specification applies to each shift independently (Null, Sensitivity, or Combined)

Low Pressure Differential, Gage, Vacuum Gage/Amplified

INTERNAL CIRCUITRY

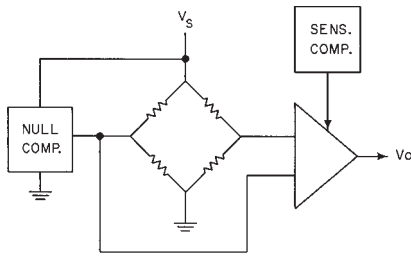

NULL AND SENSITIVITY TEMPERATURE SHIFT

Amplified pressure sensors are 100% tested to insure that the maximum null and sensitivity temperature shift does not exceed the specification. The diagram below illustrates how null and sensitivity shift relates to temperature. Note that the maximum shift occurs at temperature extremes. Therefore, if a sensor is not ex-

posed to the entire temperature range, the maximum null and sensitivity shift will actually be less than the value specified.

This diagram indicates the temperature shift pertaining to a few listings. Maximum null and sensitivity shift varies from listing to listing.

NOTES

1. Terminals are labeled on the sensor.
2. Input and output share a common ground.
3. R_i must be greater than or equal to 3000 ohms.

RATIOMETRICITY

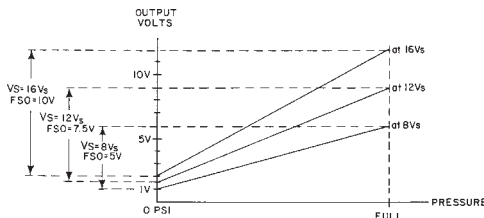

Ratiometricity refers to the output voltage being directly proportional to supply voltage. 160PC sensors in this catalog are calibrated at 8 VDC supply voltage (except 163PC) to provide a 1-6 volt (5 V Span) output swing. For example, if supply increases by 50% to 12 VDC, the output voltage increased by 50% to 1.5-9 volts (7.5 V Span).

NOTE

The output is not perfectly ratiometric. See Accuracy specifications for the degree of error.

NULL AND SENSITIVITY SHIFT (% F.S.O.)

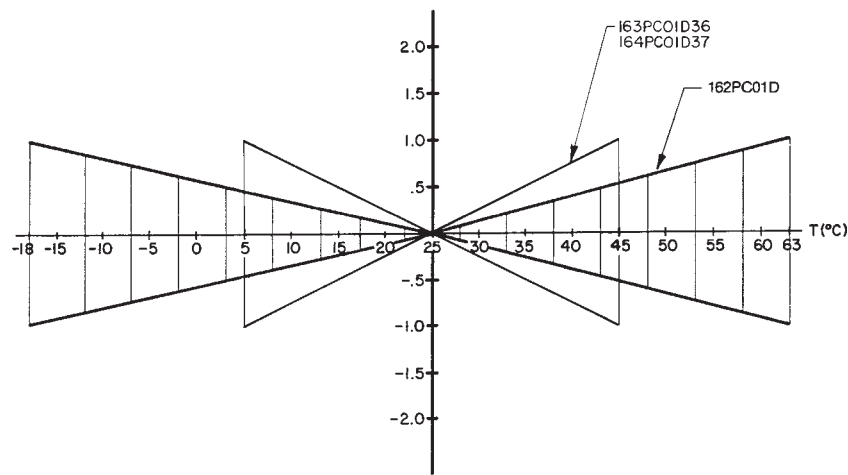

Amplified

SCALING OF 160PC SERIES SENSORS WITH 8V EXCITATIONS

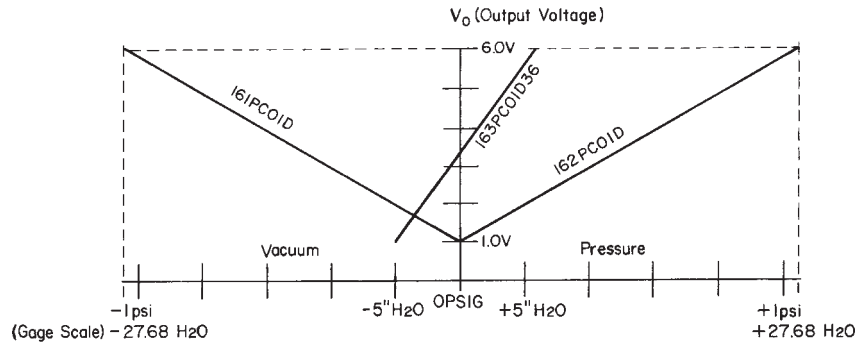

161PC01D	Vacuum Gage	$V_o = 1 \text{ V at } 0 \text{ psig \& } 6 \text{ V at } -1 \text{ psig}$
162PC01D	Differential	$V_o = 1 \text{ V at } 0 \text{ psig \& } 6 \text{ V at } 1 \text{ psig}$
163PC01D36	Differential	$V_o = 1 \text{ V at } -5'' \text{ H}_2\text{O \& } 6 \text{ V at } -5'' \text{ H}_2\text{O}$

NOTE: 161PC sensors are scaled for greater pressure on the P1 side of the chip. 162PC sensors are scaled for greater pressure on the P2 side of the chip. Other scalings available upon request.

Pressure Sensors

160PC Series

Low Pressure Differential, Gage, Vacuum Gage/Amplified

MOUNTING DIMENSIONS (For reference only)

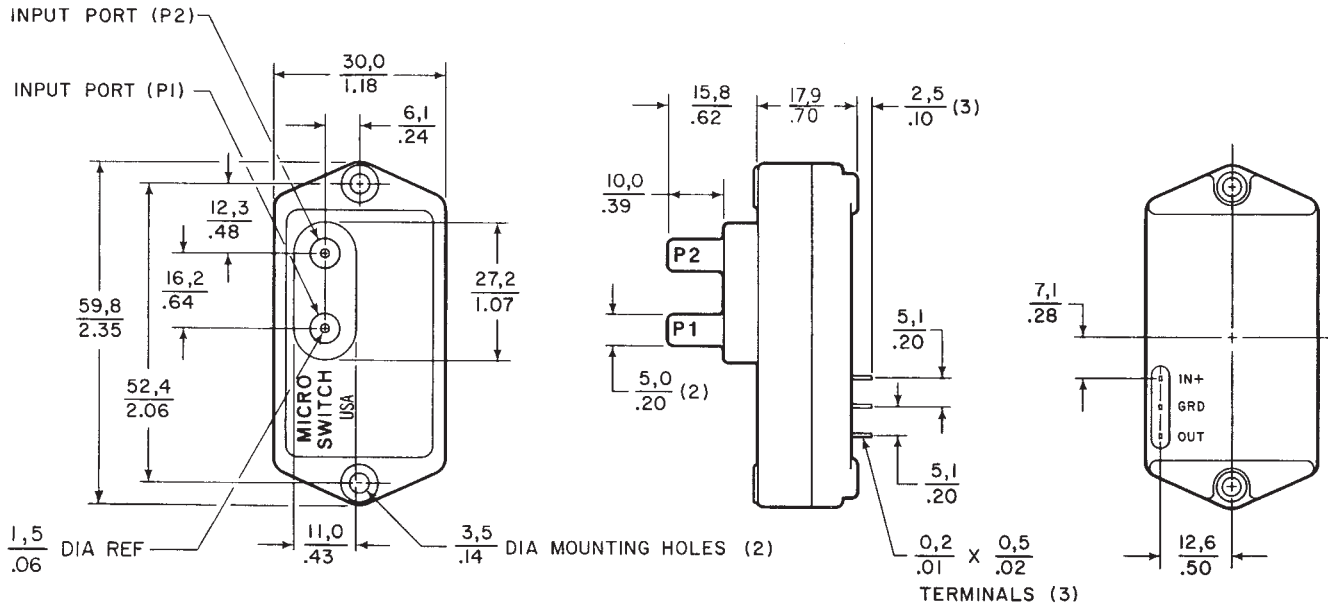

160PC CONSTRUCTION

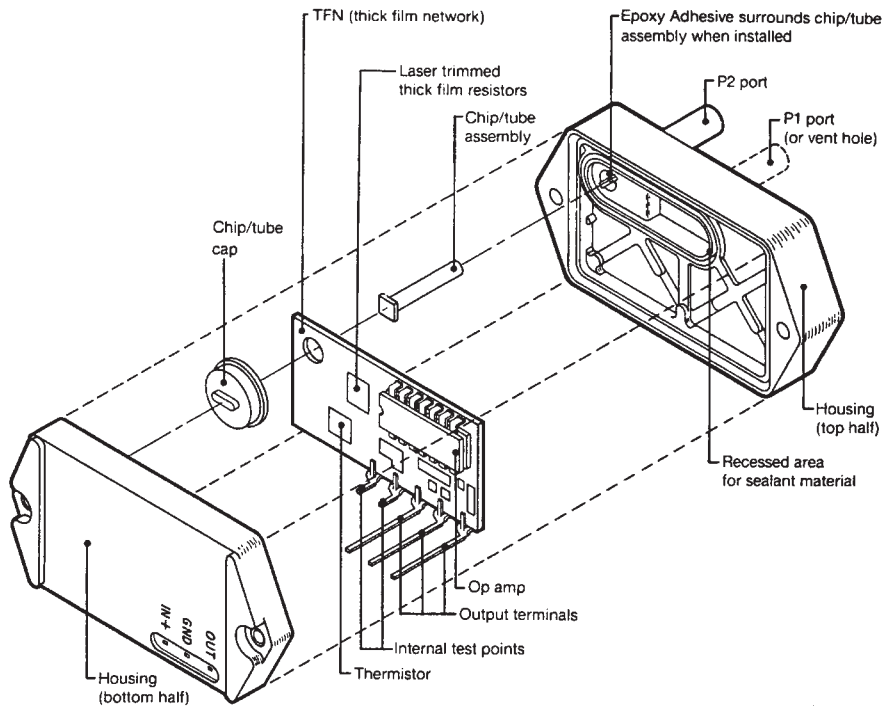

Данный компонент на территории Российской Федерации

Вы можете приобрести в компании MosChip.

Для оперативного оформления запроса Вам необходимо перейти по данной ссылке:

<http://moschip.ru/get-element>

Вы можете разместить у нас заказ для любого Вашего проекта, будь то серийное производство или разработка единичного прибора.

В нашем ассортименте представлены ведущие мировые производители активных и пассивных электронных компонентов.

Нашей специализацией является поставка электронной компонентной базы двойного назначения, продукции таких производителей как XILINX, Intel (ex.ALTERA), Vicor, Microchip, Texas Instruments, Analog Devices, Mini-Circuits, Amphenol, Glenair.

Сотрудничество с глобальными дистрибьюторами электронных компонентов, предоставляет возможность заказывать и получать с международных складов практически любой перечень компонентов в оптимальные для Вас сроки.

На всех этапах разработки и производства наши партнеры могут получить квалифицированную поддержку опытных инженеров.

Система менеджмента качества компании отвечает требованиям в соответствии с ГОСТ Р ИСО 9001, ГОСТ РВ 0015-002 и ЭС РД 009

Офис по работе с юридическими лицами:

105318, г.Москва, ул.Щербаковская д.3, офис 1107, 1118, ДЦ «Щербаковский»

Телефон: +7 495 668-12-70 (многоканальный)

Факс: +7 495 668-12-70 (доб.304)

E-mail: info@moschip.ru

Skype отдела продаж:

moschip.ru

moschip.ru_4

moschip.ru_6

moschip.ru_9