



SY58621L

Precision 3.2Gbps CML/LVPECL Backplane Transceiver with Integrated Loopback

General Description

The SY58621L is a low jitter, high-speed transceiver with a variable swing LVPECL transmitter buffer and a CML high-gain receiver optimized for precision telecom and enterprise server transmission line and backplane data management. The SY58621L distributes data to 3.2Gbps guaranteed over temperature and voltage.

The SY58621L transmitter differential input includes Micrel's unique, patented 3-pin input termination architecture that directly interfaces to any (AC- or DC-coupled) differential signal as small as 100mV (200mV_{PP}) without any termination resistor network in the signal path. The receiver differential input is optimized to interface directly to AC-coupled signals as small as 10mV (20mV_{PP}). The receiver output is 50_ source-terminated CML and the transmitter output is variable swing 80mV to 800mV LVPECL with extremely fast rise/fall time.

To support remote self-testing, the SY58621L features a high-speed loopback test mode. The input control signal LOOPBACK enables an internal loopback path from the transmitter input to the receiver output.

The SY58621L operates from a 3.3V $\pm 10\%$ supply and is guaranteed over the full industrial temperature range of -40°C to $+85^{\circ}\text{C}$. The SY58621L is part of Micrel's high-speed, Precision Edge[®] product line. For applications that requires a CML receiver and transmitter, consider the SY58620L.

All support documentation can be found on Micrel's web site at: www.micrel.com.

Applications

- Backplane management
- Active cable transceivers
- SONET/SDH data/clock applications
- 4X Fibre Channel applications



Precision Edge[®]

Features

- Guaranteed AC performance over temperature and voltage:
 - Maximum Throughput 3.2Gbps
 - $<160\text{ps}$ t_r/t_f time
- Transmitter
 - Patented input termination directly interfaces to AC- or DC-coupled differential inputs
 - Variable swing LVPECL output
- Receiver
 - 32dB high-gain Input
 - Internal 50 Ω input termination
 - Accepts AC-coupled input signals as small as 10mV (20mV_{PP})
 - 400mV (800mV_{PP}) differential CML output swing
- Loss-of-Signal (LOS)
 - High-gain, TTL-compatible LOS output with internal 4.75k Ω pull-up
 - Programmable LOS level set
- Ultra-low jitter design
 - $<5\text{ps}_{\text{RMS}}$ random jitter
- Patent-pending MUX isolates the receiver and the transmitter channels minimizing on crosstalk
- Selectable loopback diagnostic mode
- Output enables on transmitter and receiver outputs
- Power supply $+3.3\text{V} \pm 10\%$
- Industrial temperature range -40°C to $+85^{\circ}\text{C}$
- Available in 24-pin (4mm x 4mm) QFN

Markets

- Precision telecom
- Enterprise server
- ATE
- Test and measurement

Precision Edge is a registered trademark of Micrel, Inc.

Micrel Inc. • 2180 Fortune Drive • San Jose, CA 95131 • USA • tel +1 (408) 944-0800 • fax + 1 (408) 474-1000 • <http://www.micrel.com>

January 2006

M9999-012006-B
hbwhelp@micrel.com or (408) 955-1690

Typical Applications

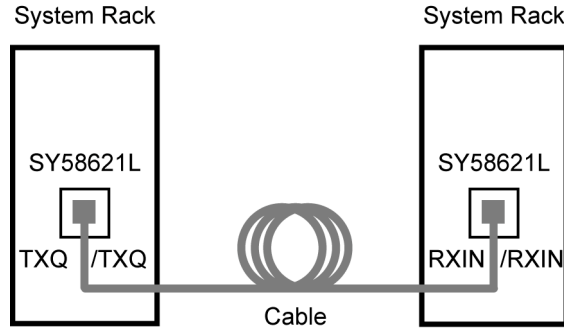

Functional Block Diagram

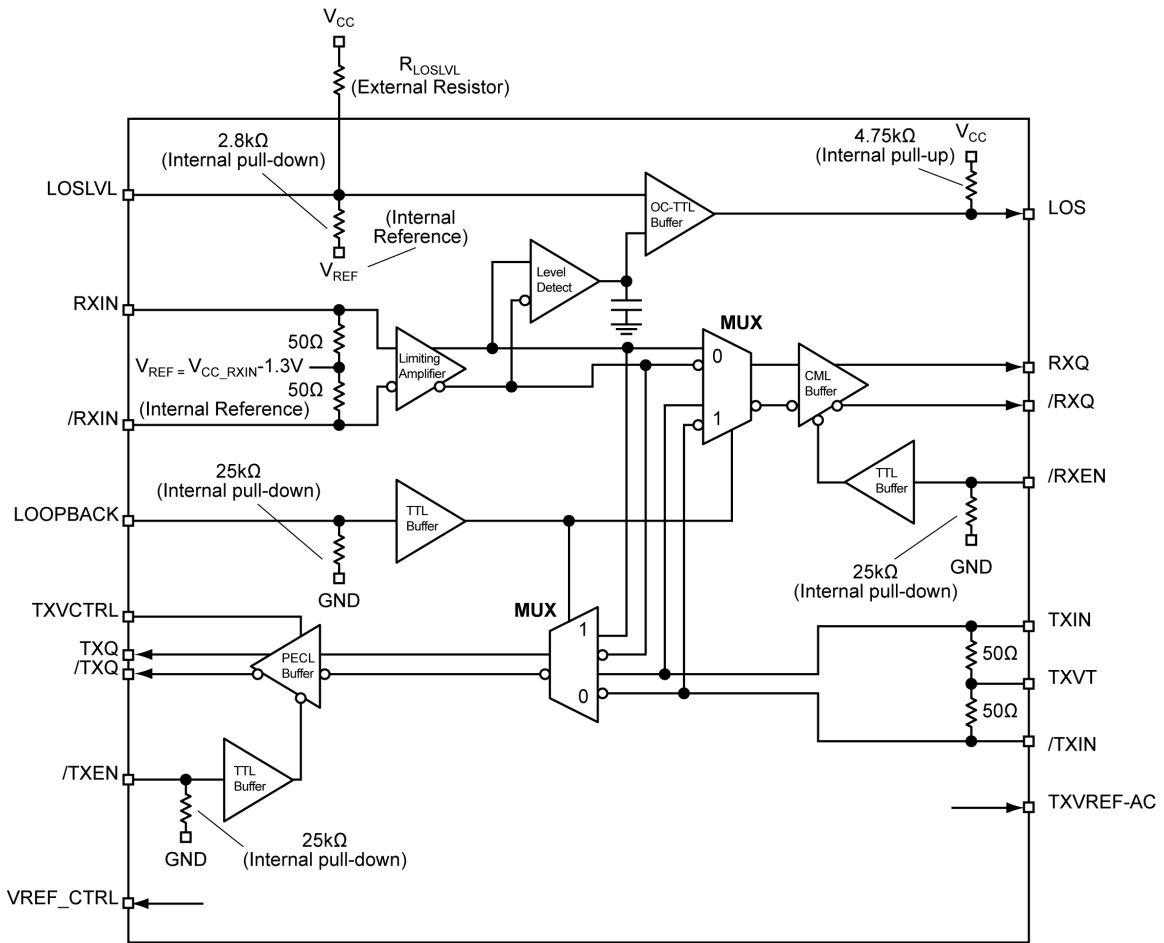

Note:
It is recommended that R_{LOSLVL} ≤ 10kΩ. See the "Typical Operating Characteristics" section for more details.

Ordering Information⁽¹⁾

Part Number	Package Type	Operating Range	Package Marking	Lead Finish
SY58621LMG	QFN-24	Industrial	621L with Pb-Free bar-line indicator	NiPdAu Pb-Free
SY58621LMGTR ⁽²⁾	QFN-24	Industrial	621L with Pb-Free bar-line indicator	NiPdAu Pb-Free

Notes:

1. Contact factory for die availability. Dice are guaranteed at T_A = 25°C, DC Electricals only.
2. Tape and Reel.

Pin Configuration

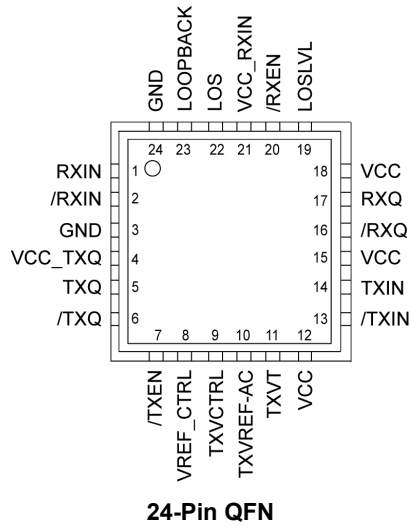

Pin Description

Inputs

Pin Number	Pin Name	Pin Description
23	LOOPBACK	LOOPBACK Mode Control. TTL/CMOS control input. LOOPBACK is an active HIGH signal used to control the LOOPBACK MUX. LOOPBACK is internally connected to a 25k Ω pull-down resistor and will default to a LOW state if left open. $V_{TH} = V_{CC}/2$.
20	/RXEN	Receiver Output Control. TTL/CMOS control input. /RXEN is an active LOW signal used to enable the receiver outputs. /RXEN is internally connected to a 25k Ω pull-down resistor and will default to a LOW state if left open. $V_{TH} = V_{CC}/2$.
1, 2	RXIN, /RXIN	Receiver Differential Input. Input accepts AC differential signals as small as 10mV (20mV _{PP}). Each pin internally terminates to $V_{CC_RXIN}-1.3V$ (internal voltage reference) through 50 Ω . Input will default to an indeterminate state if left open. See figure 6b.
7	/TXEN	Transmitter Output Control. TTL/CMOS control input. /TXEN is an active LOW signal used to enable the transmitter output. /TXEN is internally connected to a 25k Ω pull-down resistor and will default to a LOW state if left open. $V_{TH} = V_{CC}/2$.
14, 13	TXIN, /TXIN	Transmitter Differential Input. Input accepts AC- or DC-coupled differential signals as small as 100mV (200mV _{PP}). Each pin terminates to the TXVT pin through 50 Ω . Note that this input will default to an indeterminate state if left open. See figure 6a.
9	TXVCTRL	Transmitter Output Swing Control. Input that controls the output amplitude of the transmitter. The operating range of the control input is from V_{REF_CTRL} (max swing) to V_{CC} (min swing). Control of the output swing can be obtained by using a variable resistor between V_{REF_CTRL} and V_{CC_TXQ} through a wiper driving TXVCTRL. Setting TXVCTRL to V_{CC_TXQ} sets the output swing to min swing. Refer to the "Interface Applications" and "Output Stage" sections for more details.
11	TXVT	Input Termination Center-Tap. Each side of the transmitter differential input pair terminates to the TXVT pin. The TXVT pin provides a center-tap to a termination network for maximum interface flexibility. Refer to the "Input Stage" section for more details.

Outputs

Pin Number	Pin Name	Pin Description
22	LOS	Loss-of-Signal Output. TTL-compatible output with internal 4.75k Ω pull-up resistor. Loss-of-Signal asserts to logic HIGH when the receiver input amplitudes fall below the threshold set by LOSLVL.
19	LOSLVL	RX Loss-of-Signal Level Set. A resistor (R_{LOSLVL}) connected between LOSLVL and V_{CC} sets the threshold for the data input amplitude at which the LOS output is asserted. Default is max sensitivity. LOSLVL is used to set the Loss-of-Signal (LOS) voltage. It is internally connected to a 2.8k Ω pull-down resistor to an internal V_{REF} voltage source. See "Typical Operating Characteristics," and "Application Implementation" sections for more details.
17, 16	RXQ, /RXQ	Receiver Differential Output. Output is CML compatible. Refer to the "Truth Table" and "Output Stage" sections for more details. Unused output pair may be left open. The output is designed to drive 400mV (800mV $_{PP}$) into 50 Ω to V_{CC} or 100 Ω across the pair.
5, 6	TXQ, /TXQ	Transmitter differential Variable Swing Output. Output is LVPECL-compatible. Please refer to the "Truth Table" section for details. Unused output pair may be left open. Each output is designed to drive 80mV (min) to 800mV (typ) into 50 Ω to $V_{CC}-2V$ depending on TXVCTRL.
8	VREF_CTRL	Transmitter Output Reference Voltage. Output biases to $V_{CC_TXQ}-1.3V$. Connecting V_{REF_CTRL} to TXVCTRL sets the transmitter output swing to max swing.
10	TXVREF-AC	Transmitter Input Reference Voltage. This output biases to $V_{CC}-1.3V$. It is used when AC coupling the transmitter input. For AC-coupled applications, connect TXVREF-AC to the TXVT pin and bypass with a 0.01 μF low ESR capacitors to V_{CC} . See "Input Stage" section for more details. Maximum sink/source current is $\pm 1.5mA$.

Power Pins

Pin Number	Pin Name	Pin Description
3, 24	GND, Exposed Pad	Ground. GND pins and exposed pad must be connected to the same ground plane.
12, 15, 18	VCC	3.3V $\pm 10\%$ Positive Power Supply. Bypass with 0.1 μF //0.01 μF low ESR capacitors and place as close to each V_{CC} pins as possible. Power pins are not connected internally and must be connected to the same power supply externally.
21	VCC_RXIN	3.3V $\pm 10\%$ Receive Input Power Supply. Bypass with 0.1 μF //0.01 μF low ESR capacitors and place as close to the V_{CC_RXIN} pin as possible. Power pins are not connected internally and must be connected to the same power supply externally.
4	VCC_TXQ	3.3V $\pm 10\%$ Output Transmit Power Supply. Bypass with 0.1 μF //0.01 μF low ESR capacitors and place as close to the V_{CC_TXQ} pin as possible. Power pins are not connected internally and must be connected to the same power supply externally.

Truth Table

LOOPBACK	RXQ	TXQ
0	RXIN	TXIN
1	TXIN	RXIN

Absolute Maximum Ratings⁽¹⁾

Supply Voltage (V _{CC} , V _{CC_TXQ} , V _{CC_RXIN})	-0.5V to +4.0V
Input Voltage		
LOSLVL V _{REF}	-1.2V to V _{CC}
LOOPBACK	-0.5V to V _{CC}
/TXEN, /RXEN	-0.5V to V _{CC}
TXVCTRL VREF_CTRL	-1.2V to V _{CC}
TXIN, /TXIN	-0.5V to V _{CC}
LVPECL Output Current (I _{OUT})		
TXQ, /TXQ		
Continuous	±50mA
Surge	±100mA
Source or Sink Current on		
TXVT	±100mA
LOS	±5mA
RXQ, /RXQ	±25mA
RXIN, /RXIN	±10mA
TXIN, /TXIN	±50mA
TXVREF-AC, VREF-CTRL	±2mA
Lead Temperature (soldering, 20sec.)	260°C
Storage Temperature (T _s)	-65°C to +150°C

Operating Ratings⁽²⁾

Supply Voltage (V _{CC} , V _{CC_TXQ} , V _{CC_RXIN})	+3.0V to +3.6V
Ambient Temperature (T _A)	-40°C to +85°C
Package Thermal Resistance ⁽³⁾		
QFN (θ _{JA})		
Still-Air	50°C/W
QFN (ψ _{JB})		
Junction-to-Board	30°C/W

DC Electrical Characteristics⁽⁴⁾

T_A = -40°C to +85°C, unless otherwise stated.

Symbol	Parameter	Condition	Min	Typ	Max	Units
V _{CC}	Power Supply		3	3.3	3.6	V
V _{CC_TXQ}	Transmit Power Supply		3	3.3	3.6	V
V _{CC_RXIN}	Receive Power Supply		3	3.3	3.6	V
I _{CC}	Power Supply Current	No load, max. V _{CC}		100	150	mA

Receiver Input DC Electrical Characteristics

V_{CC_RXIN} = 3.3V ±10%; T_A = -40°C to +85°C, unless otherwise stated.

Symbol	Parameter	Condition	Min	Typ	Max	Units
R _{IN}	Input Resistance (RXIN to VREF)		45	50	55	Ω
R _{DIFF_IN}	Input Resistance (RXIN to /RXIN)		90	100	110	Ω
V _{IN}	Input Voltage Swing (RXIN, /RXIN)	See Figure 5a AC-coupled	10		900	mV
V _{DIFF_IN}	Differential Input Voltage Swing RXIN - /RXIN	See Figure 5b AC-coupled	20		1800	mV
V _{REF}	Internal Reference Voltage		V _{CC_RXIN} -1.48	V _{CC_RXIN} -1.32	V _{CC_RXIN} -1.16	V

Notes:

1. Permanent device damage may occur if absolute maximum ratings are exceeded. This is a stress rating only and functional operation is not implied at conditions other than those detailed in the operational sections of this data sheet. Exposure to absolute maximum rating conditions for extended periods may affect device reliability.
2. The data sheet limits are not guaranteed if the device is operated beyond the operating ratings.
3. Package thermal resistance assumes exposed pad is soldered (or equivalent) to the devices most negative potential on the PCB. θ_{JA} and ψ_{JB} values are determined for a 4-layer board in still-air, unless otherwise stated.
4. The circuit is designed to meet the DC specifications shown in the above table after thermal equilibrium has been established.

Receiver Output DC Electrical Characteristics

$V_{CC} = 3.3V \pm 10\%$, $R_L = 100\Omega$ across the outputs; $T_A = -40^\circ C$ to $+85^\circ C$, unless otherwise stated.

Symbol	Parameter	Condition	Min	Typ	Max	Units
V_{OH}	Output HIGH Voltage (RXQ, /RXQ)	$R_L = 50\Omega$ to V_{CC}	$V_{CC} - 0.020$	$V_{CC} - 0.010$	V_{CC}	V
V_{OUT}	Output Voltage Swing (RXQ, /RXQ)	See Figure 5a	325	400	500	mV
V_{DIFF_OUT}	Differential Output Voltage Swing (RXQ, /RXQ)	See Figure 5b	650	800	1000	mV
R_{OUT}	Single-Ended Output Impedance		45	50	55	Ω
R_{DIFF_OUT}	Differential Output Impedance		90	100	110	Ω
V_{OFFSET}	Differential Output Offset	$R_L = 50\Omega$ to V_{CC} , limiting mode	-140		+140	mV

Transmitter Input DC Electrical Characteristics

$V_{CC} = 3.3V \pm 10\%$; $T_A = -40^\circ C$ to $+85^\circ C$, unless otherwise stated.

Symbol	Parameter	Condition	Min	Typ	Max	Units
R_{IN}	Input Resistance (TXIN to TXVT)		45	50	55	Ω
R_{DIFF_IN}	Differential Input Resistance (TXIN to /TXIN)		90	100	110	Ω
V_{IH}	Input HIGH Voltage (TXIN, /TXIN)		1.2		V_{CC}	V
V_{IL}	Input LOW Voltage (TXIN, /TXIN)		0		$V_{IH} - 0.1$	V
V_{IN}	Input Voltage Swing (TXIN, /TXIN)	See Figure 5a	0.1		V_{CC}	V
V_{DIFF_IN}	Differential Input Voltage Swing TXIN - /TXIN	See Figure 5b	0.2			V
V_{T_IN}	TXIN, /TXIN to VT				1.28	V
V_{TXVREF_AC}	Output Reference Voltage		$V_{CC} - 1.4$	$V_{CC} - 1.3$	$V_{CC} - 1.3$	V
V_{REF_CTRL}	Output Reference Voltage		$V_{CC} - 1.4$	$V_{CC} - 1.3$	$V_{CC} - 1.3$	V
$V_{TXVCTRL}$	Input Voltage (TXVCTRL)		V_{REF_CTRL}		V_{CC}	V

Transmitter Output DC Electrical Characteristics

$V_{CC_TXQ} = 3.3V \pm 10\%$, $R_L = 50\Omega$ to $V_{CC_TXQ} - 2V$; $T_A = -40^\circ C$ to $+85^\circ C$, unless otherwise stated.

Symbol	Parameter	Condition	Min	Typ	Max	Units
V_{OH}	Output HIGH Voltage (TXQ, /TXQ)		$V_{CC_TXQ} - 1.145$	$V_{CC_TXQ} - 1.020$	$V_{CC_TXQ} - 0.895$	V
V_{OL}	Output LOW Voltage (TXQ, /TXQ)	TXVCTRL = V_{REF_CTRL}	$V_{CC_TXQ} - 1.945$	$V_{CC_TXQ} - 1.820$	$V_{CC_TXQ} - 1.695$	V
		TXVCTRL = V_{CC_TXQ}		$V_{CC_TXQ} - 1.100$		V
V_{OUT}	Output Voltage Swing (TXQ, /TXQ)	TXVCTRL = V_{REF_CTRL} See Figure 5a	550	800		mV
		TXVCTRL = V_{CC_TXQ} See Figure 5a		80		mV
V_{DIFF_OUT}	Differential Output Voltage Swing (TXQ, /TXQ)	TXVCTRL = V_{REF_CTRL} See Figure 5b	1100	1600		mV
		TXVCTRL = V_{CC_TXQ} See Figure 5b		160		mV

LVTTTL/CMOS INPUT DC Control Electrical Characteristics⁽⁵⁾

$V_{CC} = 3.3V \pm 10\%$; $T_A = -40^\circ C$ to $+85^\circ C$, unless otherwise stated.

Symbol	Parameter	Condition	Min	Typ	Max	Units
V_{IL}	/TXEN, /RXEN, LOOPBACK				0.8	V
V_{IH}	/TXEN, /RXEN, LOOPBACK		2			V
I_{IL}	/TXEN, /RXEN, LOOPBACK	$I_{IL}@V_{IN} = 0.5V$	0		50	μA
I_{IH}	/TXEN, /RXEN, LOOPBACK	$I_{IH}@V_{IN} = V_{CC}$			300	μA

Note:

5. /TXEN, /RXEN, and LOOPBACK have an internal pull-down 25k Ω resistor.

LOS DC Electrical Characteristics

$V_{CC} = 3.3V \pm 10\%$; $T_A = -40^\circ C$ to $+85^\circ C$.

Symbol	Parameter	Condition	Min	Typ	Max	Units
V_{LOSLVL}	LOSLVL Voltage Range		V_{REF}		V_{CC}	V
V_{OH}	Output HIGH Voltage	Source 100 μ A; $V_{CC} \geq 3.3V$	2.4			V
V_{OL}	Output LOW Voltage	Sink 2mA			0.5	V
VSR	LOS Sensitivity Range		7		35	mV _{PP}
LOS _{AL}	Low LOS Assert Level	$R_{LOSLVL} = 10k\Omega$ 2 ⁷ -1 Data Pattern, Note 7	622Mbps	15		mV
			3.2Gbps	10		mV
LOS _{DL}	Low LOS De-assert Level	$R_{LOSLVL} = 10k\Omega$ 2 ⁷ -1 Data Pattern, Note 7	622Mbps	20		mV
			3.2Gbps	15		mV
HYS _L	Low LOS Hysteresis	$R_{LOSLVL} = 10k\Omega$, limiting mode 2 ⁷ -1 Data Pattern, Note 6 and 7	622Mbps	3		dB
			3.2Gbps	5.5		dB
LOS _{AM}	Medium LOS Assert Level	$R_{LOSLVL} = 5k\Omega$ 2 ⁷ -1 Data Pattern, Note 7	622Mbps	20		mV
			3.2Gbps	15		mV
LOS _{DM}	Medium LOS De-assert Level	$R_{LOSLVL} = 5k\Omega$ 2 ⁷ -1 Data Pattern, Note 7	622Mbps	30		mV
			3.2Gbps	25		mV
HYS _M	Medium LOS Hysteresis	$R_{LOSLVL} = 5k\Omega$, limiting mode 2 ⁷ -1 Data Pattern, Note 6 and 7	622Mbps	4		dB
			3.2Gbps	5.5		dB
LOS _{AH}	High LOS Assert Level	$R_{LOSLVL} = 1k\Omega$ 2 ⁷ -1 Data Pattern, Note 7	622Mbps	35		mV
			3.2Gbps	30		mV
LOS _{DH}	High LOS De-assert Level	$R_{LOSLVL} = 1k\Omega$ 2 ⁷ -1 Data Pattern, Note 7	622Mbps	60		mV
			3.2Gbps	55		mV
HYS _H	High LOS Hysteresis	$R_{LOSLVL} = 1k\Omega$, limiting mode 2 ⁷ -1 Data Pattern, Note 6 and 7	622Mbps	5		dB
			3.2Gbps	5.5		dB

Notes:

6. Hysteresis is defined as: $20\log_{10} \left(\frac{SD_AssertVoltage}{SD_De-assertVoltage} \right) dB$.

7. See the "Typical Operating Characteristics" section for more details on R_{LOSLVL} and its associated LOS assert and de-assert amplitudes for a 2⁷-1 PRBS data pattern. See the "PRBS Discussion" section for more details on the 2⁷-1 PRBS data pattern.

AC Electrical Characteristics⁽⁸⁾

$V_{CC} = V_{CC_TXQ} = V_{CC_RXIN} = 3.3V \pm 10\%$, Receiver Load: $R_L = 100\Omega$ across the outputs. Transmitter Load: $R_L = 50\Omega$ to $V_{CC_TXQ} - 2V$; $T_A = -40^\circ C$ to $+85^\circ C$, unless otherwise stated.

Receiver and Transmitter

Symbol	Parameter	Condition	Min	Typ	Max	Units
t_{JITTER}	Deterministic Jitter (DJ)	Note 9			Note 13	ps _{PP}
	Random Jitter (RJ)	Note 10		0.7	5	ps _{RMS}
	Crosstalk-Induced Jitter	Note 11			1.2	ps _{RMS}

Receiver

Symbol	Parameter	Condition	Min	Typ	Max	Units
f_{MAX}	Maximum Operating Frequency	$V_{RXIN} \geq 10mV$ (20mV _{PP})	3.2			Gbps
BW	-3dB	$V_{RXIN} \geq 10mV$ (20mV _{PP})		2.5		GHz
S_{21}	Single-Ended Gain	Linear mode		32		dB
$A_{V(DIFF)}$	Differential Voltage Gain	Linear mode		38		dB
t_r, t_f	Output Rise/Fall Time (20% to 80%)	Limiting mode		60	120	ps
LOS Frequency Range	LOS Operating Frequency Range	Note 12	0.622		3.2	Gbps
t_{OFF}	LOS De-assert Time			0.1	0.5	μs
t_{ON}	LOS Assert Time			0.2	0.5	μs

Transmitter

Symbol	Parameter	Condition	Min	Typ	Max	Units
f_{MAX}	Maximum Operating Frequency	$V_{TXIN} \geq 100mV$ (200mV _{PP})	3.2			Gbps
BW	-3dB	$V_{REF_CTRL} \leq TXCTRL \leq V_{CC_TXQ}$		2		GHz
t_r, t_f	Output Rise/Fall Time (20% to 80%)	$V_{TXVCTRL} = V_{REF_CTRL}$		100	160	ps

Notes:

8. High-frequency AC-parameters are guaranteed by design and characterization.
9. Deterministic jitter is measured with both K28.5 and $2^{23}-1$ PRBS data-pattern, measured at $<f_{MAX}$. $V_{IN} = 10mV$ (20mV_{pp}) RX, 100mV (200mV_{pp}) TX. See the "PRBS Discussion" section for more details on the K28.5 and $2^{23} - 1$ PRBS data pattern.
10. Random jitter is measured with a K28.7 character pattern, measured at $<f_{MAX}$. $V_{IN} = 10mV$ (20mV_{pp}) RX, 100mV (200mV_{pp}) TX. See the "PRBS Discussion" section for more details on the K28.7 PRBS data pattern.
11. Crosstalk is measured at the output while applying two similar differential clock frequencies that are asynchronous with respect to each other at the inputs.
12. LOS is guaranteed to be chatter-free at $f_{MAX} \geq 622Mbps$ or $f_{MAX} \geq 311MHz$ with $V_{RXIN} \geq 10mV$ (20mV_{pp}) with a 2^7-1 PRBS data pattern.
13. Contact factory for limits.

Detailed Description

Receiver

The receiver AC-coupled differential input distributes data to 3.2Gbps with signals as small as 10mV (20mV_{PP}) or as large as 900mV (1.8V_{PP}). The receiver input features an internal 50Ω input termination connected to an internal reference which optimizes the inputs for AC-coupled signals. Input signals are linearly amplified with 38dB of differential gain and the output signal is limited to 400mV (800mV_{PP}).

The receiver output buffer features 50Ω source termination resistors and a current source that provides 400mV (800mV_{PP}) swing into 50Ω termination. The output buffers terminates to standard CML loads (100Ω across the output pair or equivalent). See the “Output Stage Receiver” section for more details.

Transmitter

The transmitter differential input includes Micrel’s unique, patented 3-pin input termination architecture that directly interfaces to any (AC- or DC-coupled) differential signal as small as 100mV (200mV_{PP}) without any termination resistor network in the signal path.

The transmitter output buffer terminates to standard LVPECL loads ($R_L = 50_ - V_{CC_TXQ} - 2V$). The output buffer is a special variable swing LVPECL buffer controlled by TXVCTRL. The output buffer features emitter follower output that provides 80mV (160mV_{PP}) to 800mV (1.6V_{PP}) swing into 50_ transmission lines. See the next section and Figures 1a and 1b for more details on how to control the variable output swing feature.

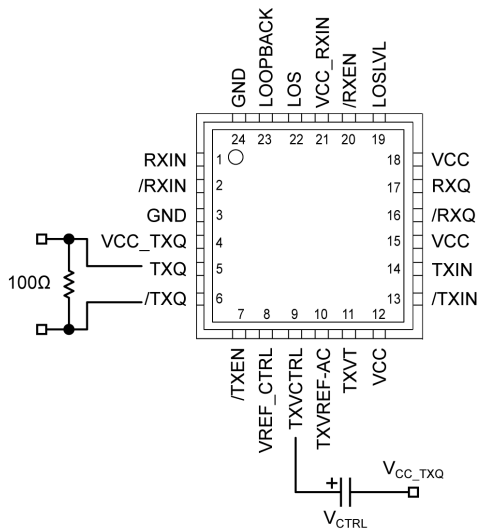

Figure 1a. Voltage Source Implementation

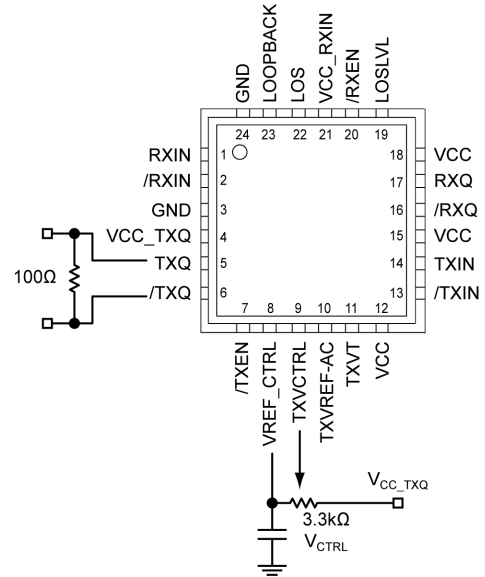

Figure 1b. Alternative Implementation

Transmitter PECL Variable-Swing Output Buffer

- Connecting V_{REF_CTRL} to TXVCTRL sets the transmitter output buffer to maximum swing
- Setting TXVCTRL to V_{CC_TXQ} , sets the transmitter output buffer to minimum swing
- Control of the transmitter output swing buffers can be obtained by using a variable resistor connected between V_{REF_CTRL} and V_{CC_TXQ} with a wiper connected to TXVCTRL as shown in Figure 1b

Receiver LOS

The SY58621L features a chatter-free Loss-of-Signal (LOS) TTL compatible output with an internal 4.75kΩ pull-up resistor. LOS circuitry monitors the input receiver signal and asserts a signal when the input signal falls below the threshold set by the programmable LOS level set pin (LOSLVL). When the amplitude of the receiver input signal falls below the threshold, LOS is asserted HIGH with a response time of ~0.2μs. LOS can be fed into /RXEN to maintain output stability by disabling the output during a Loss-of-Signal condition. Figure 2a and 2b shows the LOS connection to /RXEN. When /RXEN is HIGH, the output signal RXQ is held LOW and /RXQ is held HIGH. Typically, 2dB of LOS hysteresis is adequate to prevent the receiver output from chattering. LOS operation is optimized for data rates ≥ 622 Mbps with an input receiver amplitude of at least 10mV (20mV_{PP}). Due to the long time constant in slower data rates below 622Mbps, the SY58621L LOS function does not guarantee chatter-free operation for low amplitude signals.

LOSLVL sets the threshold of the LOS input amplitude detection. Connecting an external resistor, R_{LOSLVL} ,

between VCC and LOSLVL sets the input amplitude LOS detection trip-point by setting up a voltage divider between VCC and V_{REF} (an internal voltage source set at V_{CC}-1.3V), since there is a 2.8kΩ internal resistor connected between LOSLVL and V_{REF}. The input voltage range of LOSLVL ranges from V_{CC} to V_{REF}. See the “Functional Block Diagram” section and Figures 2a and 2b, to see how R_{LOSLVL} sets up a voltage divider between VCC and V_{REF}. See the “LOS Output DC Electrical Characteristics” table and “Typical Operating Characteristics” section to see how different R_{LOSLVL} values affect LOS sensitivity.

connected to VCC with a wiper connected to LOSLVL, as shown in Figure 2b

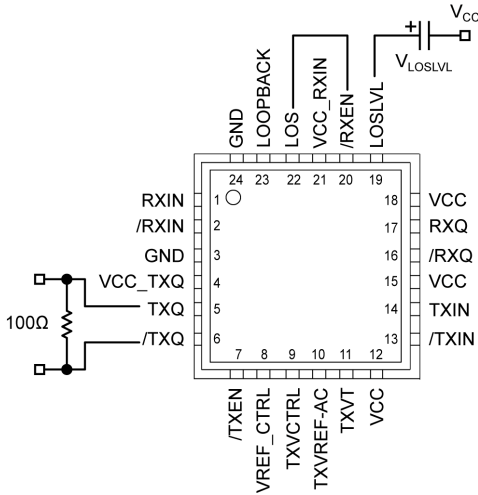

Figure 2a. Voltage Source Implementation

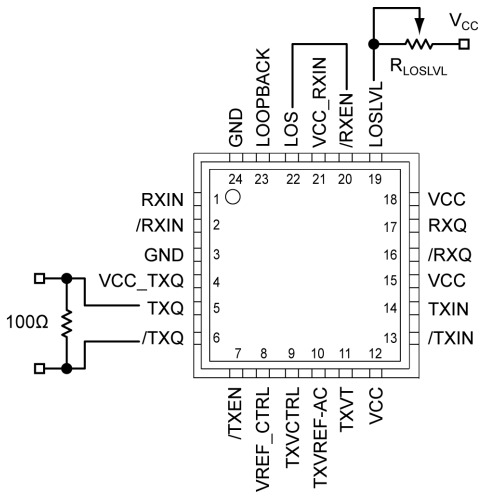

Figure 2b. Alternative Implementation

LOS Output

- Connecting the input /RXEN to the LOS output as shown in Figures 2a and 2b, maintains receiver output stability under a Loss-of-Signal condition
- Sensitivity of the LOS signal can be programmed using the LOSLVL input by using a variable resistor

- $\geq 2\text{dB}$ hysteresis is insured if $R_{\text{LOS}_{\text{LVL}}} \leq 10\text{k}\Omega$
- LOS is guaranteed chatter-free at $f \geq 622\text{Mbps}$ (311MHz)

Hysteresis

The SY58621L provides a minimum of 2dB of LOS hysteresis, see the Figure 3 for more details.

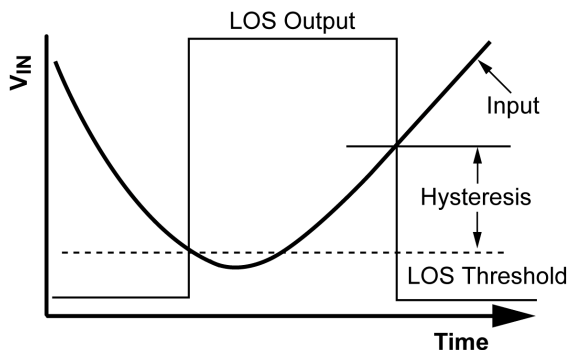

Figure 3. LOS Hysteresis Assert/De-assert

Hysteresis is defined as: $20\text{Log}_{10}\left(\frac{SD_AssertVoltage}{SD_De-assertVoltage}\right)\text{dB}$.

Loopback

To support diagnostic system testing, the SY58621L features a loopback test mode, activated by setting LOOPBACK to logic HIGH. Loopback mode enables an internal loopback path from the transmitter input to the receiver output and supports the full 3.2Gbps data rate throughput.

Crosstalk

The SY58621L features a patent-pending isolation between the receiver and transmitter channels. The following guide lines can be used to minimize on layout induced crosstalk:

1. Ground Stripping

Ground stripping is an effective method to reduce crosstalk. Ground stripping involves running a ground trace between the receiver and transmitter channels.

2. Vertical and Horizontal Traces

Another way to reduce crosstalk is to route the receiver and transmitter channels on separate layers with an embedded ground or power supply layer between the layers. When routing the traces on different layers, run the receiver traces horizontal to the transmitter traces and route the transmitter traces vertical to the receiver traces.

PRBS Discussion

LOS Testing

The LOS function is tested with a 2^7-1 PRBS (Pseudo Random Bit Stream) data-pattern. A PRBS data-pattern of 2^7-1 is used because it is a good approximation to an 8b10b-encoded NRZ data stream. 8b10b encodes 8 bits of data and replaces it with 10 bits of symbol. The extra bits are added to improve transition density and the BER (Bit Error Rate) of the system.

Deterministic Jitter Testing and the K28.5 Pattern

The K28.5 (11000001010011111010) and $2^{23}-1$ PRBS data-patterns are used to characterize DJ because both data patterns have lower spectral frequency content which provides a best approximation to scrambled NRZ data streams.

Random Jitter Testing and the K28.7 Pattern

The K28.7 (11111100000...) data pattern is used to measure RJ since the pattern is free of DJ. In addition, because the K28.7 data-pattern can be used to compare the T_N (N^{TH} period) to the T_0 (1^{st} period), low frequency jitter components can be accumulated.

Power Supply Filtering

Although the SY58621L is fully differential, it is recommended that the power supplies are filtered as shown in Figure 4.

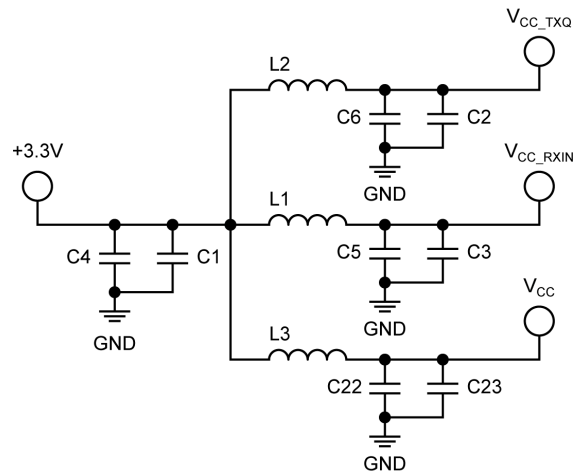

Figure 4. Power Supply Filtering Scheme

Item	Description
C1, C2, C3, C23	0.1µF Capacitor
C4, C5, C6, C22	0.01µF Capacitor
L1, L2, L3	1.2µH Ferrite Bead Inductor

Table 1. Bill of Materials

Typical Operating Characteristics

$V_{CC} = V_{CC_TXQ} = V_{CC_RXIN} = 3.3V \pm 10\%$, Receiver: $R_L = 100\Omega$ across the outputs. Transmitter: $R_L = 50\Omega$ to V_{CC_TXQ} $-2V$; $T_A = 25^\circ C$, unless otherwise stated.

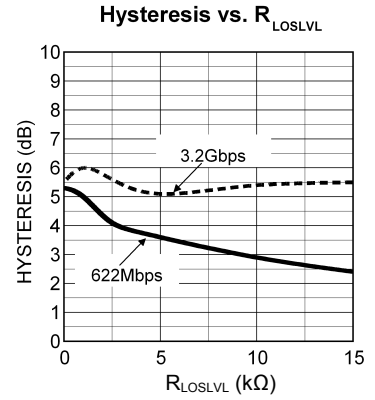
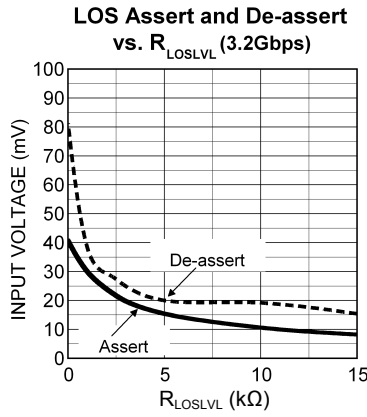
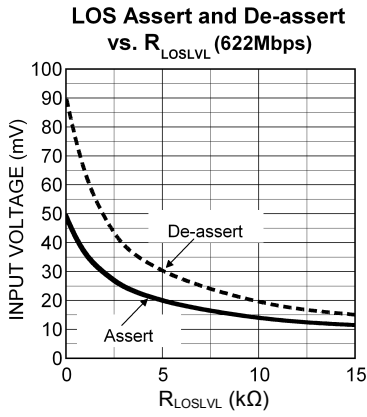

Single-Ended and Differential Swings

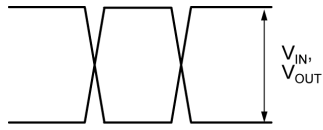

Figure 5a. Single-Ended Voltage Swing

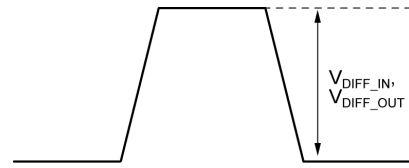

Figure 5b. Differential Voltage Swing

Input Stage

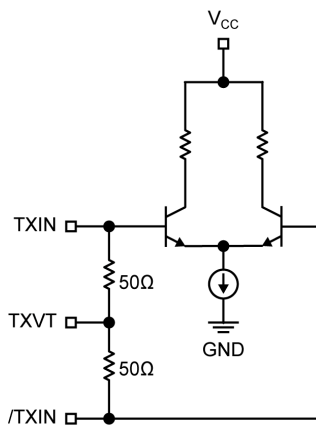

Figure 6a. TX Simplified Differential Input Stage

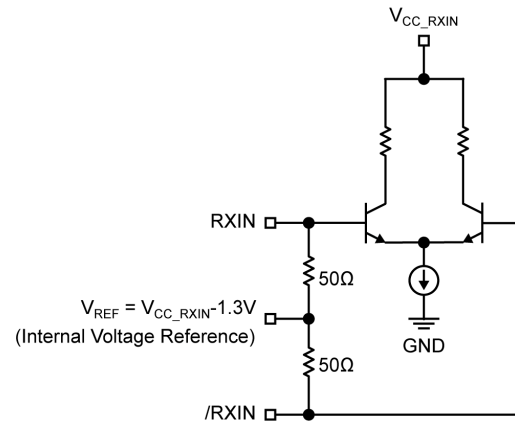

Figure 6b. RX Simplified Differential Input Stage

Output Stage Receiver

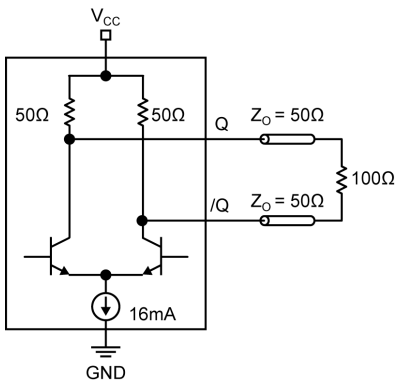

Figure 7a. Receiver CML DC-Coupled Output

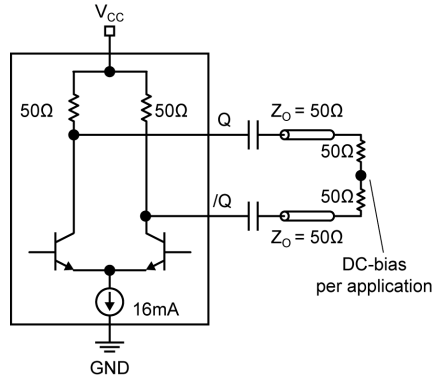

Figure 7b. Receiver CML AC-Coupled Output

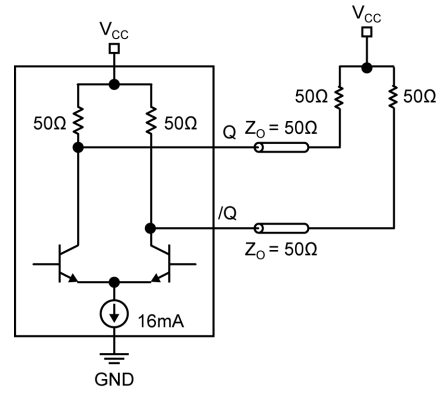

Figure 7c. Receiver CML DC-Coupled Output (50Ω to Vcc)

Transmitter

The transmitters output is a variable swing LVPECL open emitter driver. LVPECL has very low output (open emitter) impedance, and small signal swing which result in low EMI.

LVPECL is ideal for driving 50Ω and 100Ω-controlled impedance transmission lines. There are several techniques for terminating the LVPECL output: Parallel Termination-Thevenin Equivalent, Parallel Termination (3-Resistor), and AC-Coupled Termination. Unused output pairs may be left floating. However, the unused half of a single-ended output must be terminated, or balanced.

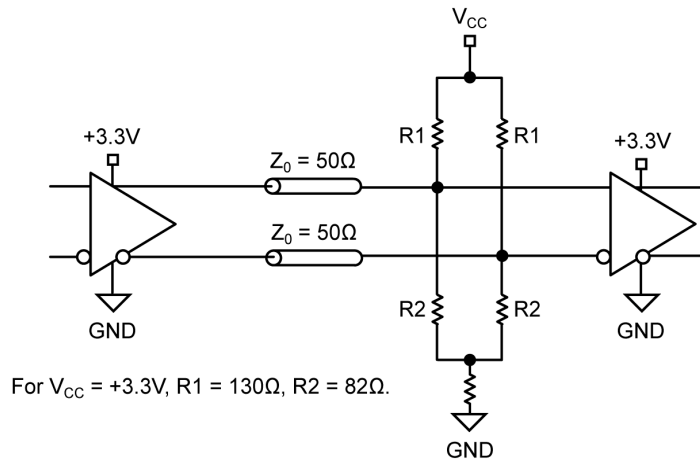

Figure 8a. Parallel Thevenin-Equivalent Termination

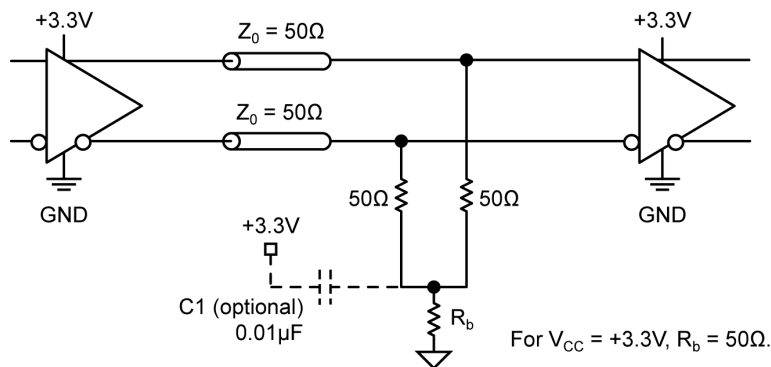
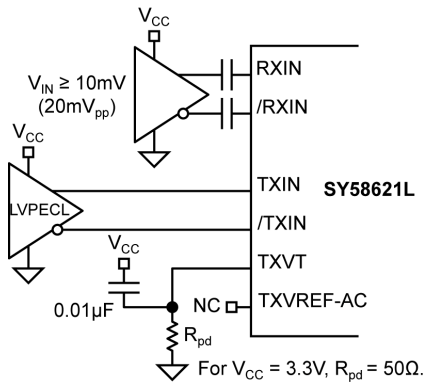
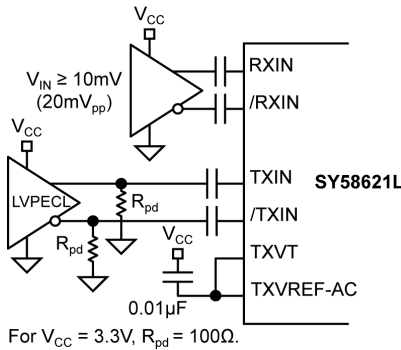

Figure 8b. Parallel Termination – 3-Resistors

Interface Applications



**Figure 9a. LVPECL Interface
(TX DC-Coupled/RX AC-Coupled)**



**Figure 9b. LVPECL Interface
(TX AC-Coupled/RX AC-Coupled)**

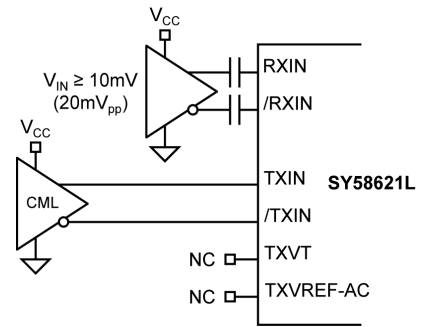

**Figure 9c. CML Interface
(TX DC-Coupled/RX AC-Coupled)**

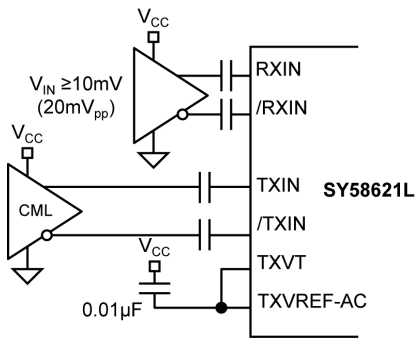

**Figure 9d. CML Interface
(TX AC-Coupled/RX AC-Coupled)**

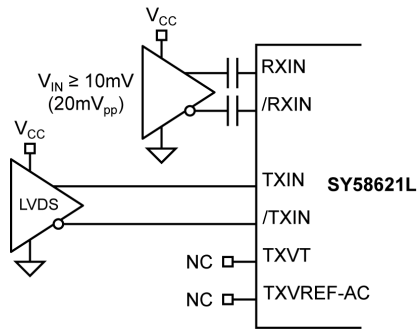
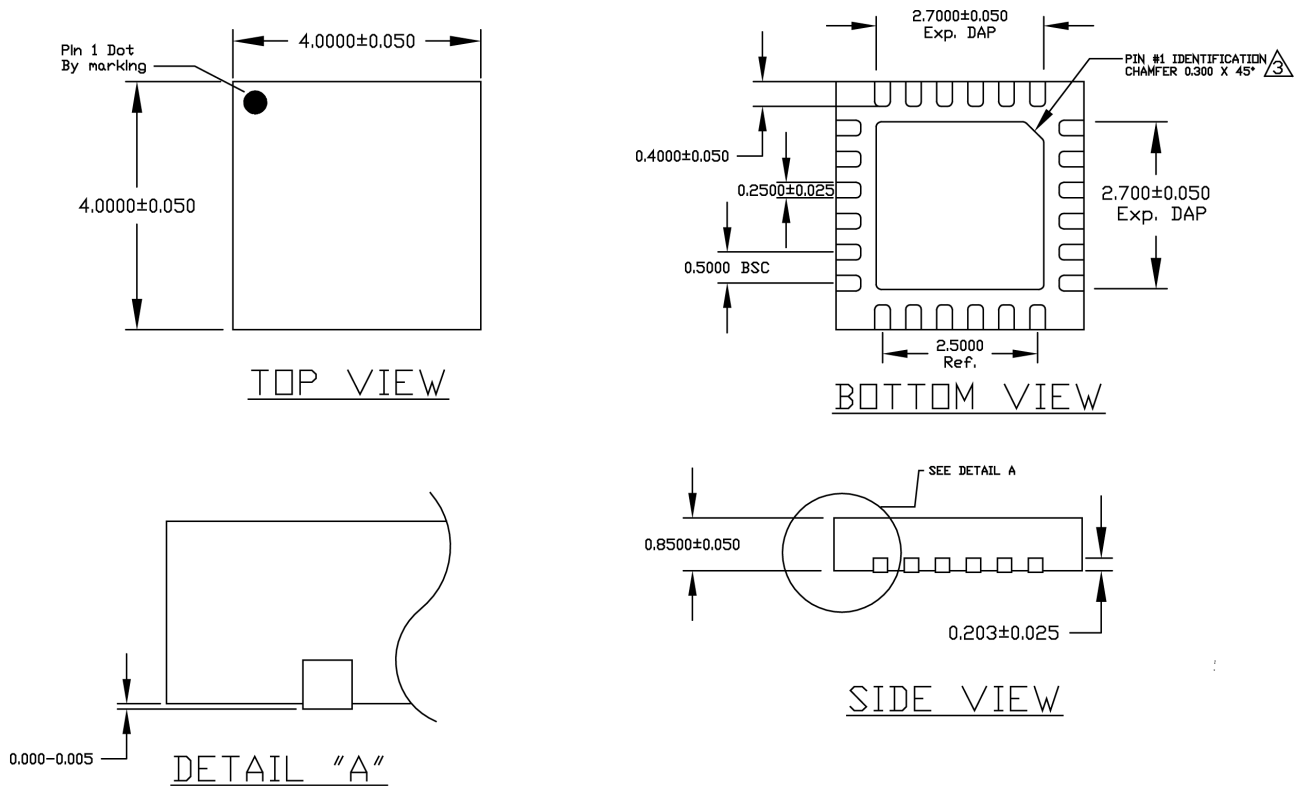

**Figure 9e. LVDS Interface
(TX DC-Coupled/RX AC-Coupled)**

Related Product and Support Documentation

Part Number	Function	Data Sheet Link
SY58620L	Precision 4.25Gbps CML Transceiver with Integrated Loopback	www.micrel.com/product-info/products/sy58620l.shtml
HBW Solutions	New Products and Applications	www.micrel.com/product-info/products/solutions.shtml

Package Information



NOTE:

1. ALL DIMENSIONS ARE IN MILLIMETERS (mm).
2. THE PIN#1 IDENTIFIER MUST EXIST ON THE TOP SURFACE OF PACKAGE BY USING IDENTIFICATION MARK OR OTHER FEATURE OF PACKAGE BODY.
3. CHAMFER STYLE PIN 1 IDENTIFIER ON BOTTOM SIDE

24-Pin QFN

MICREL, INC. 2180 FORTUNE DRIVE SAN JOSE, CA 95131 USA
 TEL +1 (408) 944-0800 FAX +1 (408) 474-1000 WEB <http://www.micrel.com>

The information furnished by Micrel in this data sheet is believed to be accurate and reliable. However, no responsibility is assumed by Micrel for its use. Micrel reserves the right to change circuitry and specifications at any time without notification to the customer.

Micrel Products are not designed or authorized for use as components in life support appliances, devices or systems where malfunction of a product can reasonably be expected to result in personal injury. Life support devices or systems are devices or systems that (a) are intended for surgical implant into the body or (b) support or sustain life, and whose failure to perform can be reasonably expected to result in a significant injury to the user. A Purchaser's use or sale of Micrel Products for use in life support appliances, devices or systems is a Purchaser's own risk and Purchaser agrees to fully indemnify Micrel for any damages resulting from such use or sale.

© 2006 Micrel, Incorporated.

Данный компонент на территории Российской Федерации

Вы можете приобрести в компании MosChip.

Для оперативного оформления запроса Вам необходимо перейти по данной ссылке:

<http://moschip.ru/get-element>

Вы можете разместить у нас заказ для любого Вашего проекта, будь то серийное производство или разработка единичного прибора.

В нашем ассортименте представлены ведущие мировые производители активных и пассивных электронных компонентов.

Нашей специализацией является поставка электронной компонентной базы двойного назначения, продукции таких производителей как XILINX, Intel (ex.ALTERA), Vicor, Microchip, Texas Instruments, Analog Devices, Mini-Circuits, Amphenol, Glenair.

Сотрудничество с глобальными дистрибьюторами электронных компонентов, предоставляет возможность заказывать и получать с международных складов практически любой перечень компонентов в оптимальные для Вас сроки.

На всех этапах разработки и производства наши партнеры могут получить квалифицированную поддержку опытных инженеров.

Система менеджмента качества компании отвечает требованиям в соответствии с ГОСТ Р ИСО 9001, ГОСТ РВ 0015-002 и ЭС РД 009

Офис по работе с юридическими лицами:

105318, г.Москва, ул.Щербаковская д.3, офис 1107, 1118, ДЦ «Щербаковский»

Телефон: +7 495 668-12-70 (многоканальный)

Факс: +7 495 668-12-70 (доб.304)

E-mail: info@moschip.ru

Skype отдела продаж:

moschip.ru

moschip.ru_4

moschip.ru_6

moschip.ru_9