

15 WATT AC-DC CONVERTER BWM-SA SERIES

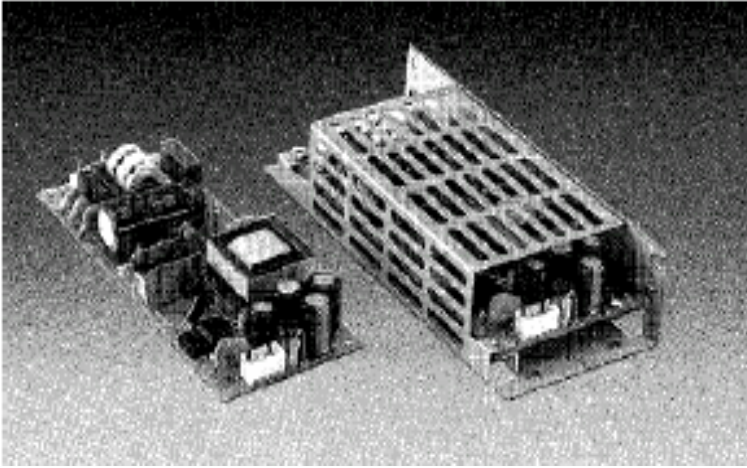

Specifications<AC/DC>	Model				
BWM**SX-U 15W ATTS/SINGLE	BWM3.3SX-U	BWM05SX-U	BWM12SX-U	BWM15SX-U	BWM24SX-U
Input Characteristic					
Input Voltage	AC100-230V				
Input Current	0.4A at AC100V/0.2A at AC230V				
Input Range	AC85-264V(DC110-370V)				
Input Frequency	50/60Hz				
Input Frequency Range	47-440Hz				
Phase	Single				
Inrush Current *1	15A(maximum) at AC100V/30A(maximum) at AC200V				
Efficiency [%] (typical) *2	71	76	81	81	83

Derating Curve

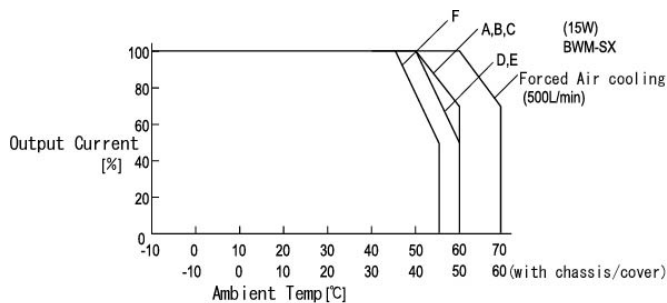

* For safety specification, contact ETA Sales Representative

Efficiency Curve

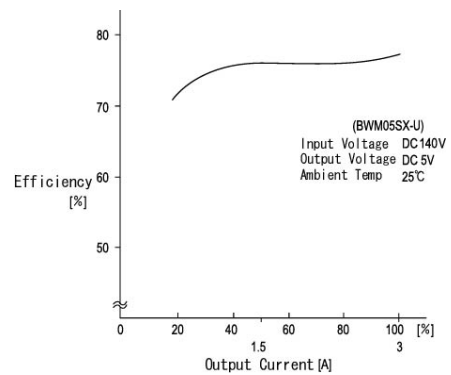

BWM / Specification

Specifications<AC/DC>	Model				
BWM**SX-U 15WATTS/SINGLE	BWM3.3SX-U	BWM05SX-U	BWM12SX-U	BWM15SX-U	BWM24SX-U
Output Characteristic					
Output Voltage [V]	3.3	5	12	15	24
Output Current [A]	3.0	3.0	1.3	1.0	0.7
Voltage Adjust Range	+/- 10% of Rated Output Voltage(at no load within the input range)				
Ripple and Noise [mVp-p](maximum) *3	83	100	170	200	290
Regulation					
Statistic Line Regulation [mV](maximum)	26.4	40	96	120	192
Statistic Load Regulation [mV](maximum)	29.7	45	108	135	216
Temperature Coefficient *4	0.03%/°C				
Drift[mV](maximum) *5	31.5	40	75	90	135
Dynamic Load Regulation [mV](typical) *6	99	150	360	450	720
Recovery Time *6	0.3mS(typical)				
Rise up time	200mS(maximum) at 25°Cand rated input/output				
Hold up time	20mS(minimum) at 25°Cand rated input/output				
Functions					
Overcurrent Protection *6 ≥05% of Rated Output Current[A]	Current Limiting with automatic recovery				
	3.15	3.15	1.37	1.05	0.74
Overvoltage Protection ≥15% of Rated Output Voltage[V]	Zener diode clamping				
	3.8	5.75	13.8	17.3	27.6
Remote Sense	not available				
Remote On/Off	not available				
Environmental					
Operating Temperature	open board type:-10 to +50°Cenclosed type:-10 to +40°C				
Operating Humidity	20 to 90%RH(non-condensing)				
Storage Temperature	-20 to +85°C				
Storage Humidity	20 to 90%RH(non-condensing)				
Withstanding Voltage	Primary-Secondary AC3,000V for 1minute Primary-Frame Ground AC2,500V for 1minute Secondary-Frame Ground AC500V for 1minute				
Isolation Resistance	Primary-Secondary-Frame Ground 50MΩ(minimum) by DC500V insulation tester				
Vibration	5-10Hz:10mm double amplitude,10-55Hz:19.6m/s ² ,20minutes' period for 60minutes each along X,Y,Z axes(non-operating)				
Shock	196m/s ²				
Cooling	Convection				
? Leakage Current	1mA(maximum) at 25°Crated input/output and rated input frequency				
? Line Conducted Noise	Built to meet FCC Part15-B Class B Built to meet VCCI Class B Built to meet EN55022 Class B				
? Safety	UL: UL1950 C-UL: CSA C22.2 No.950 VDE EN60950, IEC950, VDE0805				
Weight (typical)	open board type:95g/enclosed type:220g				
? MTBF [H]	700,000				
? Switching Frequency[kHz](typical) *7	60	50	50	50	50

Conditions:

*1 at cold start

*2 at DC130V input/rated output

*3 measured by a bayonet probe at the end of a pair of 20cm long wires terminated with a 47uF electrolytic capacitor and 0.1uF film capacitor in parallel at a 0 to 100MHz bandwidth

*4 open board type: at -10 to +50°Cenclosed type: at -10 to +40°C

*5 for 7hour period after 1hour warm-up at 25°Cand rated input/output

*6 for less than 1minute of overcurrent and short circuit

*7 variable on input voltage and load conditions



ETA-USA

HIGH QUALITY SWITCHING POWER SUPPLIES

OCP Curve

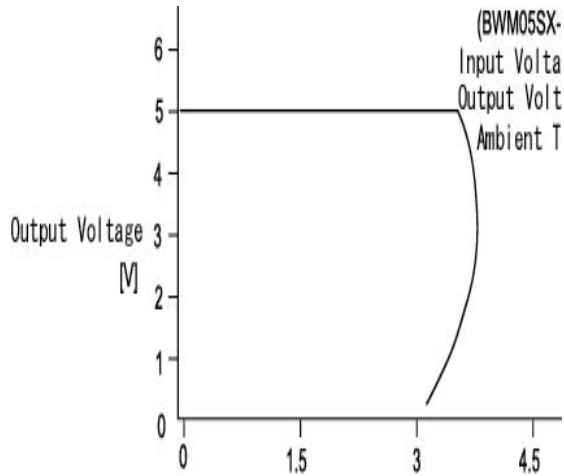

Block Diagram

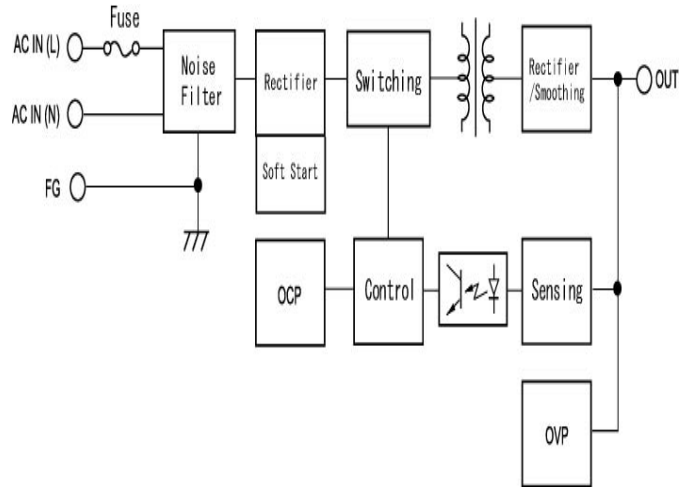

Dimension (mm)

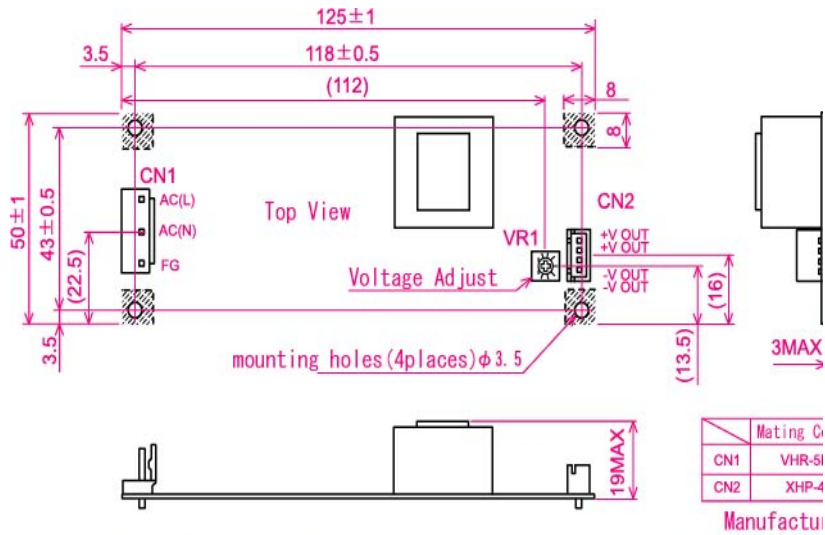

cover comes in touch when installed(dimensions in maximum)

Данный компонент на территории Российской Федерации

Вы можете приобрести в компании MosChip.

Для оперативного оформления запроса Вам необходимо перейти по данной ссылке:

<http://moschip.ru/get-element>

Вы можете разместить у нас заказ для любого Вашего проекта, будь то серийное производство или разработка единичного прибора.

В нашем ассортименте представлены ведущие мировые производители активных и пассивных электронных компонентов.

Нашей специализацией является поставка электронной компонентной базы двойного назначения, продукции таких производителей как XILINX, Intel (ex.ALTERA), Vicor, Microchip, Texas Instruments, Analog Devices, Mini-Circuits, Amphenol, Glenair.

Сотрудничество с глобальными дистрибьюторами электронных компонентов, предоставляет возможность заказывать и получать с международных складов практически любой перечень компонентов в оптимальные для Вас сроки.

На всех этапах разработки и производства наши партнеры могут получить квалифицированную поддержку опытных инженеров.

Система менеджмента качества компании отвечает требованиям в соответствии с ГОСТ Р ИСО 9001, ГОСТ РВ 0015-002 и ЭС РД 009

Офис по работе с юридическими лицами:

105318, г.Москва, ул.Щербаковская д.3, офис 1107, 1118, ДЦ «Щербаковский»

Телефон: +7 495 668-12-70 (многоканальный)

Факс: +7 495 668-12-70 (доб.304)

E-mail: info@moschip.ru

Skype отдела продаж:

moschip.ru

moschip.ru_4

moschip.ru_6

moschip.ru_9