

HONEYWELL  
PART NUMBER  
SEE TABLE, SHEET-2

REV	DOCUMENT	CHANGED BY	CHECK
E	0042016	MPH 01AUG08	CMH

HIH-4000-001 / HIH-4000-003 / HIH-4000-005

HIH-4000-002 / HIH-4000-004

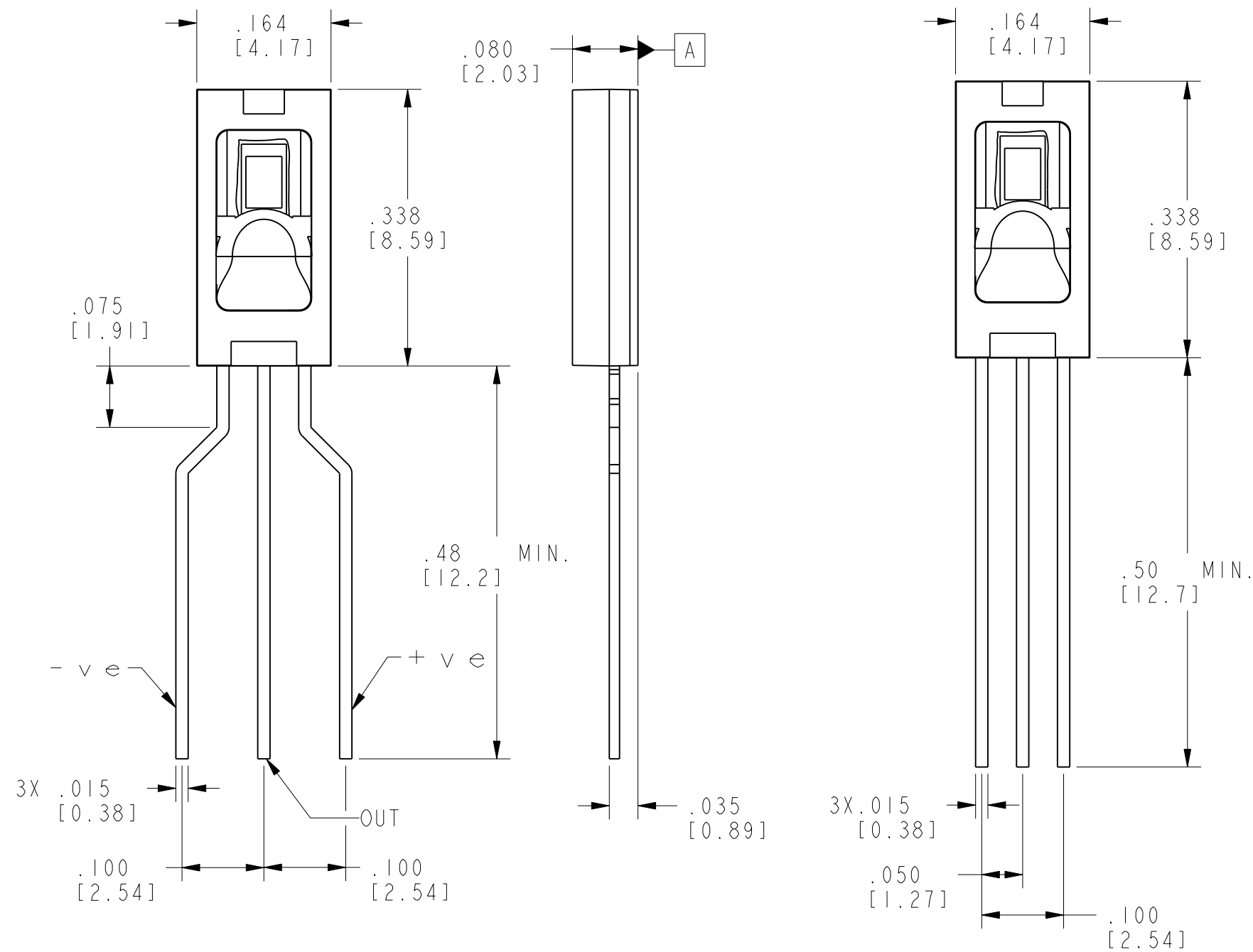

**OPERATING CHARACTERISTICS**  
at 5.0 VDC AND 25°C UNLESS OTHERWISE NOTED

SPECIFICATION	MIN	TYP	MAX	UNITS
INTERCHANGEABILITY 0 to 59%RH	-5		5	% RH
60% to 100%RH	-8		8	% RH
ACCURACY, (BFSL) $\triangle 8$	-3.5		+3.5	% RH
HYSTERESIS		3		% RH
REPEATABILITY		$\pm 0.5$		% RH
SETTLING TIME			70	mS
RESPONSE TIME, 1/e IN SLOW MOVING AIR		5		Sec.
STABILITY, AT 50%RH IN 1 YEAR		$\pm 1.2$		% RH
POWER REQUIREMENTS $\triangle 1$ VOLTAGE SUPPLY	4		5.8	VDC
CURRENT SUPPLY		200	500	$\mu A$
VOLTAGE OUTPUT, 1st ORDER CURVE FIT	$V_{out} = (V_{supply})(0.0062(\text{SENSOR RH}) + 0.16)$ TYP at 25°C			
TEMPERATURE COMPENSATION	TRUE RH = (SENSOR RH) / (1.0546 - 0.00216T), T IN °C			
OUTPUT VOLTAGE TEMPERATURE COEFFICIENT AT 50%RH, 5V		-4		mV/°C
OPERATING TEMPERATURE	-40	SEE CHART	85	°C
OPERATING HUMIDITY $\triangle 2$	0	SEE CHART	100	% RH
STORAGE TEMPERATURE	-50		125	°C
STORAGE HUMIDITY $\triangle 2$	SEE CHART			% RH

NOTES

- $\triangle 1$  - DEVICE IS CALIBRATED AT 5 VDC AND 25°C
- $\triangle 2$  - NONCONDENSING ENVIRONMENT. WHEN LIQUID WATER FALLS ON THE HUMIDITY SENSOR DIE, OUTPUT GOES TO A LOW RAIL CONDITION INDICATING NO HUMIDITY
- $\triangle 3$  - CROSS-HATCHED OPERATING ZONE LIMITED TO <50 HOURS
- $\triangle 4$  - NO SPECIFICATION ZONE
- 5 - DEVICE IS RATIO-METRIC TO SUPPLY VOLTAGE
- 6 - EXTENDED EXPOSURE TO >=90% RH CAUSES A REVERSIBLE SHIFT OF 3% RH
- 7 - THIS SENSOR IS LIGHT SENSITIVE AND SHOULD BE SHIELDED FROM BRIGHT LIGHT TO ACHIEVE BEST PERFORMANCE
- $\triangle 8$  - CAN ONLY BE ACHIEVED WITH THE SUPPLIED SLOPE AND OFFSET -003 AND -004 PARTS.



DESIGN UNITS: INCH TOLERANCES UNLESS NOTED:	DRAWN TMM 22FEB05 CHECK PM 24MAR05	<b>Honeywell</b>		
NO PLACES X $\pm$ 0.040 ONE PLACE .X $\pm$ 0.030 TWO PLACE .XX $\pm$ 0.015 THREE PLACE .XXX $\pm$ 0.010 FOUR PLACE .XXXX $\pm$ 0.0005 ANGLES X $\pm$ 2	THIS DRAWING COVERS A PROPRIETARY ITEM AND IS THE PROPERTY OF HONEYWELL. THIS DRAWING IS NOT TO BE COPIED OR USED WITHOUT THE PERMISSION OF HONEYWELL.			
THIRD ANGLE PROJECTION	INTERPRET PER ASME Y14.5M-1994 OTHER HONEYWELL ENGINEERING STANDARDS MAY APPLY	SCALE 6:1	SHEET 1 OF 2	

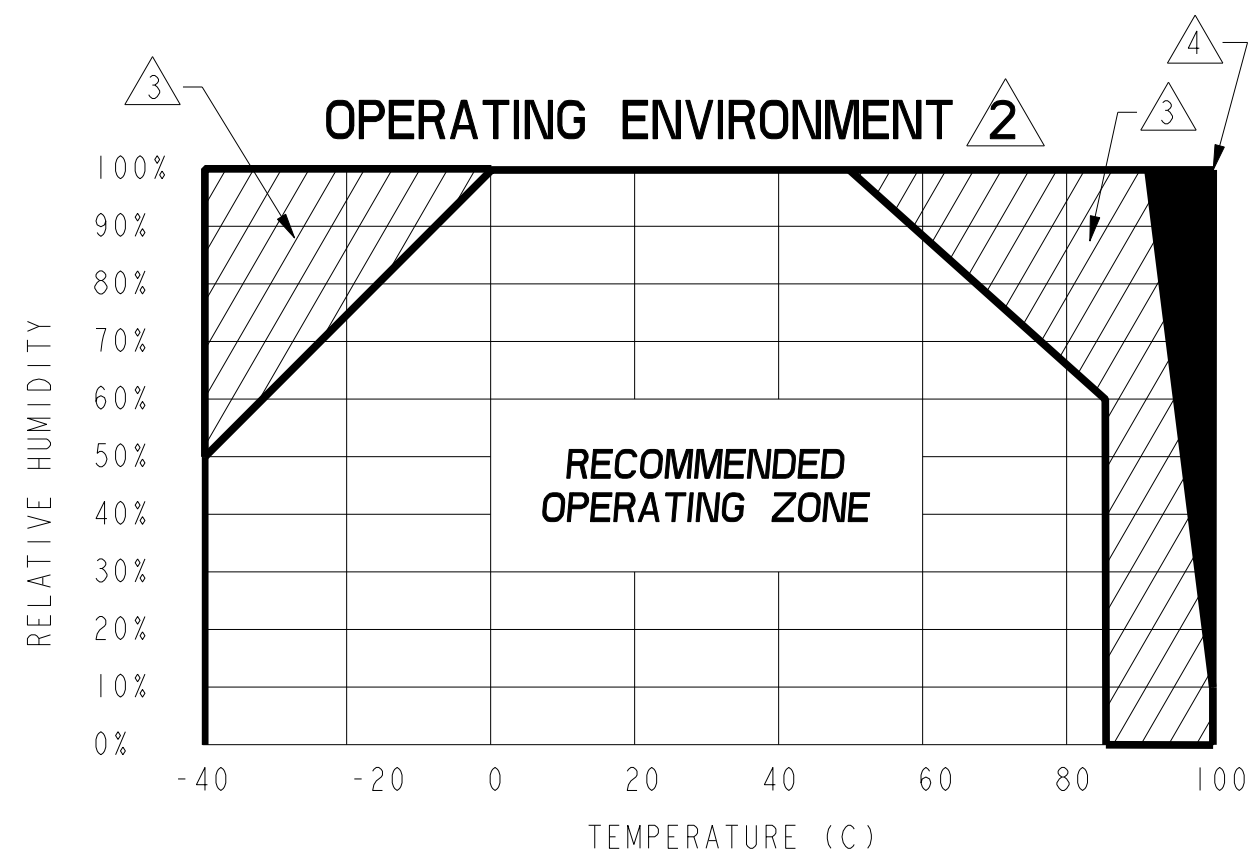
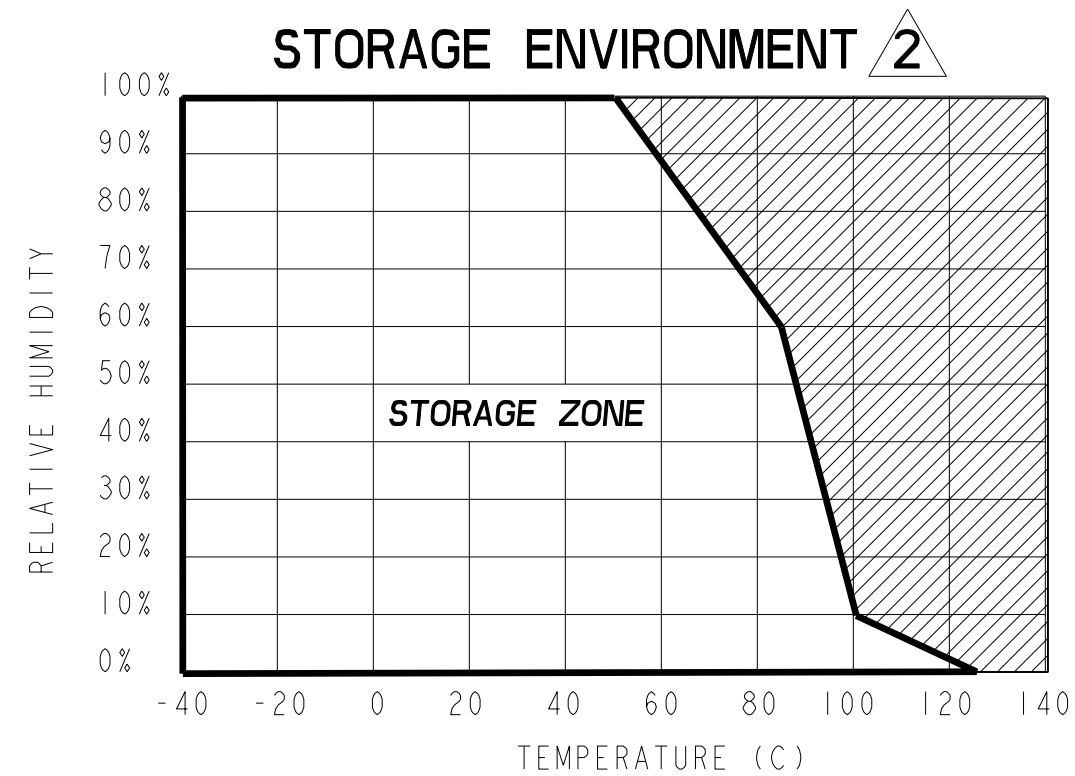

PRODUCT DESCRIPTION	
CATALOG LISTING	DESCRIPTION
HIH-4000-001	INTEGRATED CIRCUIT HUMIDITY SENSOR, 0.100 IN LEAD PITCH SIP
HIH-4000-002	INTEGRATED CIRCUIT HUMIDITY SENSOR, 0.050 IN LEAD PITCH SIP
HIH-4000-003	INTEGRATED CIRCUIT HUMIDITY SENSOR, 0.100 IN LEAD PITCH SIP WITH CALIBRATION AND DATA PRINTOUT
HIH-4000-004	INTEGRATED CIRCUIT HUMIDITY SENSOR, 0.050 IN LEAD PITCH SIP WITH CALIBRATION AND DATA PRINTOUT
HIH-4000-005	EQUIVALENT TO HIH-4000-001

DATA PRINTOUT (EXAMPLE)	
MODEL	HIH-4000-003
CHANNEL	92
WAFER	030996M
MRP	337313
CALCULATED VALUES AT 5 V	
Vout @ 0% RH	0.958 V
Vout @ 75.3% RH	3.268 V
LINEAR OUTPUT FOR 3.5% RH ACCURACY @ 25 °C	
ZERO OFFSET	0.958 V
SLOPE	30.680 mV/%RH
SENSOR RH	(Vout-ZERO OFFSET)/SLOPE (Vout-0.958)/0.0307
RATIOMETRIC RESPONSE FOR 0 TO 100% RH	
Vout	Vsupply (0.1915 TO 0.8130)

THIS DRAWING COVERS A PROPRIETARY ITEM AND IS THE PROPERTY OF HONEYWELL. THIS DRAWING IS NOT TO BE COPIED OR USED WITHOUT THE PERMISSION OF HONEYWELL.		<b>Honeywell</b>			
		SIZE	DWG TYPE	DRAWING NAME	REV
		<b>C</b>	<b>I</b>	<b>HIH-4000 SERIES CHART 1</b>	<b>E</b>
SCALE 6:1		SHEET 2 OF 2			

## Данный компонент на территории Российской Федерации

### Вы можете приобрести в компании MosChip.

Для оперативного оформления запроса Вам необходимо перейти по данной ссылке:

<http://moschip.ru/get-element>

Вы можете разместить у нас заказ для любого Вашего проекта, будь то серийное производство или разработка единичного прибора.

В нашем ассортименте представлены ведущие мировые производители активных и пассивных электронных компонентов.

Нашей специализацией является поставка электронной компонентной базы двойного назначения, продукции таких производителей как XILINX, Intel (ex.ALTERA), Vicor, Microchip, Texas Instruments, Analog Devices, Mini-Circuits, Amphenol, Glenair.

Сотрудничество с глобальными дистрибьюторами электронных компонентов, предоставляет возможность заказывать и получать с международных складов практически любой перечень компонентов в оптимальные для Вас сроки.

На всех этапах разработки и производства наши партнеры могут получить квалифицированную поддержку опытных инженеров.

Система менеджмента качества компании отвечает требованиям в соответствии с ГОСТ Р ИСО 9001, ГОСТ РВ 0015-002 и ЭС РД 009

### Офис по работе с юридическими лицами:

105318, г.Москва, ул.Щербаковская д.3, офис 1107, 1118, ДЦ «Щербаковский»

Телефон: +7 495 668-12-70 (многоканальный)

Факс: +7 495 668-12-70 (доб.304)

E-mail: [info@moschip.ru](mailto:info@moschip.ru)

Skype отдела продаж:

moschip.ru

moschip.ru\_4

moschip.ru\_6

moschip.ru\_9