

Simple 90V, 20mA, Temperature Compensated Constant Current LED Driver IC

Features

- ▶ 5.0 to 90V operating range (V_{A-B})
- ▶ 20mA $\pm 10\%$ at 5.0 - 90V
- ▶ 0.01%/°C typical temperature coefficient
- ▶ Available in TO-243AA (SOT-89), TO-252 (D-PAK), & TO-92 packages
- ▶ Can be paralleled for higher current

Applications

- ▶ LED driver
- ▶ Industrial lamp indicators
- ▶ Signage
- ▶ Accent lighting
- ▶ Automotive
- ▶ Constant current source
- ▶ Constant current sink

General Description

The Supertex CL2 is a high voltage, temperature compensated, constant current source. The device is trimmed to provide a constant current of 20mA $\pm 10\%$ at an input voltage of 5.0 - 90V. The device can be used as a two terminal constant current source or constant current sink.

A typical application for the CL2 is to drive LEDs with a constant current of 20mA. Multiple CL2s can also be used in parallel to provide higher currents such as 40mA, 60mA or 80mA. The device is available in TO-243AA (SOT-89), TO-252 (D-PAK), and TO-92 packages.

Typical Application Circuit

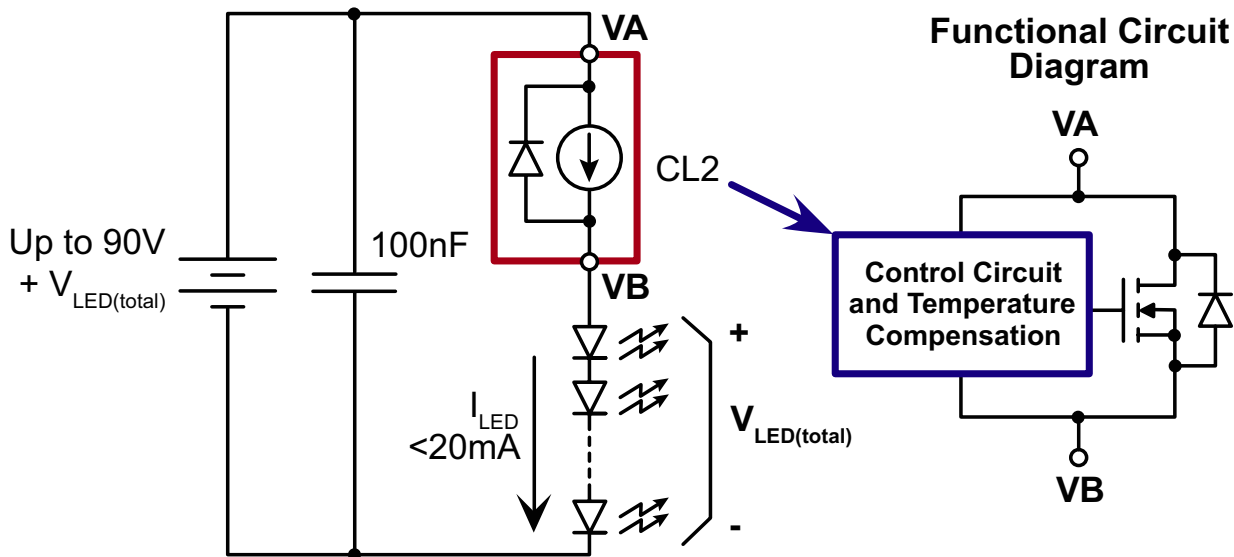

Ordering Information

Part Number	Package Options	Packing
CL2K4-G	TO-252 (D-PAK)	2000/Reel
CL2N3-G	TO-92	1000/Bag
CL2N3-G P002	TO-92	2000/Reel
CL2N3-G P003	TO-92	2000/Reel
CL2N3-G P005	TO-92	2000/Reel
CL2N3-G P013	TO-92	2000/Reel
CL2N3-G P014	TO-92	2000/Reel
CL2N8-G	TO-243AA (SOT-89)	2000/Reel

-G indicates package is RoHS compliant ('Green')
 Refer to 'P0xx' Tape & Reel Specs for P002, P003, P005, P013, and P014 TO-92 Taping Specifications and Winding Styles

Absolute Maximum Ratings

Parameter	Value
Operating voltage, V_{A-B}	100V
Operating junction temperature, T_j	-40°C to +125°C
Storage temperature, T_s	-55°C to +150°C

Absolute Maximum Ratings are those values beyond which damage to the device may occur. Functional operation under these conditions is not implied. Continuous operation of the device at the absolute rating level may affect device reliability. All voltages are referenced to device ground.

Typical Thermal Characteristics

Package	Power Dissipation @ $T_A = 25^\circ\text{C}$ (W)	θ_{ja} (°C/W)
TO-252	2.0*	81*
TO-92	0.6	132
TO-243AA	1.3*	133*

* Mounted on FR4 board; 25mm x 25mm x 1.57mm

Electrical Characteristics ($T_A = 25^\circ\text{C}$ unless otherwise specified)

Sym	Parameter	Min	Typ	Max	Units	Conditions
V_{A-B}	Operating voltage	5.0	-	90	V	---
I_{A-B}	Current regulation	18.0	20	22	mA	$V_{A-B} = 5.0\text{V} - 90\text{V}$
$\Delta I_{A-B}/\Delta T$	I_{A-B} temperature coefficient	-	0.01	-	%/°C	$V_{A-B} = 45\text{V}, T_j = -40^\circ\text{C}$ to $+100^\circ\text{C}$
T_j	Operating junction temperature	-40	-	125	°C	---
R_{A-B}	Dynamic resistance	-	300	-	kΩ	---



Pin Configurations

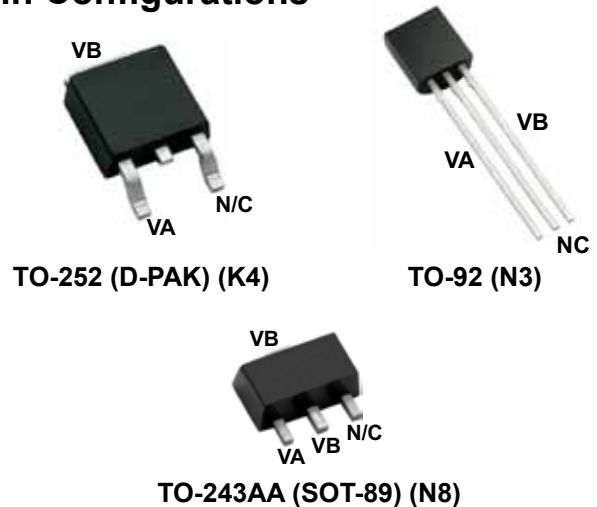

Product Marking

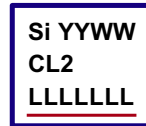

YY = Year Sealed
 WW = Week Sealed
 L = Lot Number
 _____ = "Green" Packaging

TO-252 (D-PAK) (K4)

Package may or may not include the following marks: Si or

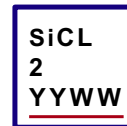

YY = Year Sealed
 WW = Week Sealed
 _____ = "Green" Packaging

TO-92 (N3)

Package may or may not include the following marks: Si or

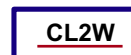

W = Code for week sealed
 _____ = "Green" Packaging

TO-243AA (SOT-89) (N8)

Package may or may not include the following marks: Si or

Functional Circuit Diagram

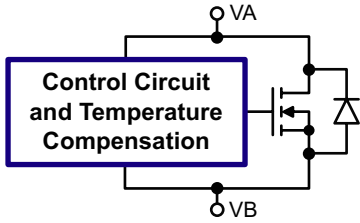

Equivalent Block Diagram

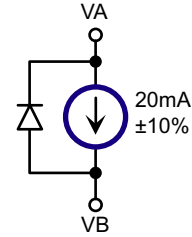

Temperature Characteristics

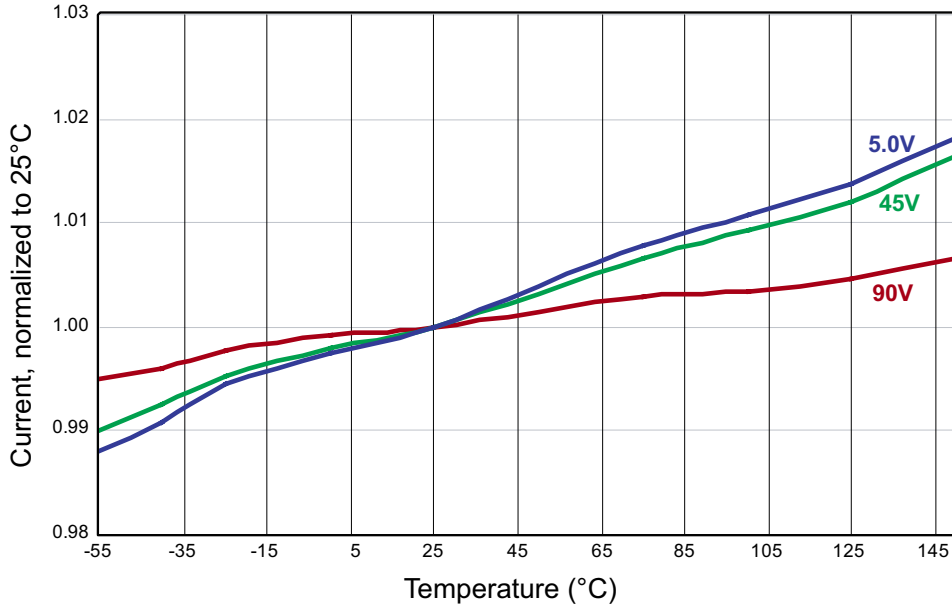

Output Current vs Voltage

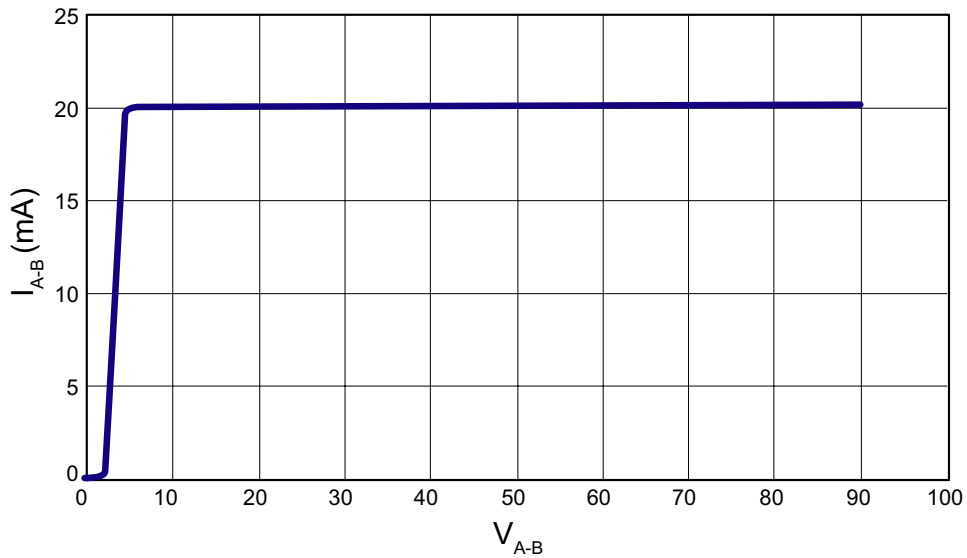

CL2 for Multiple LED Strings

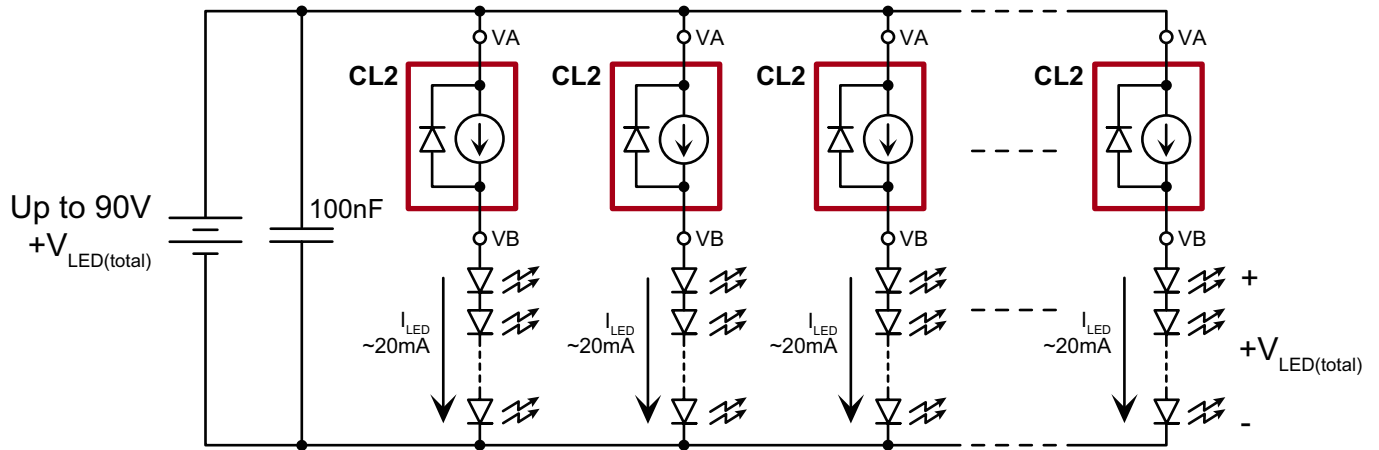

CL2 for Higher Current

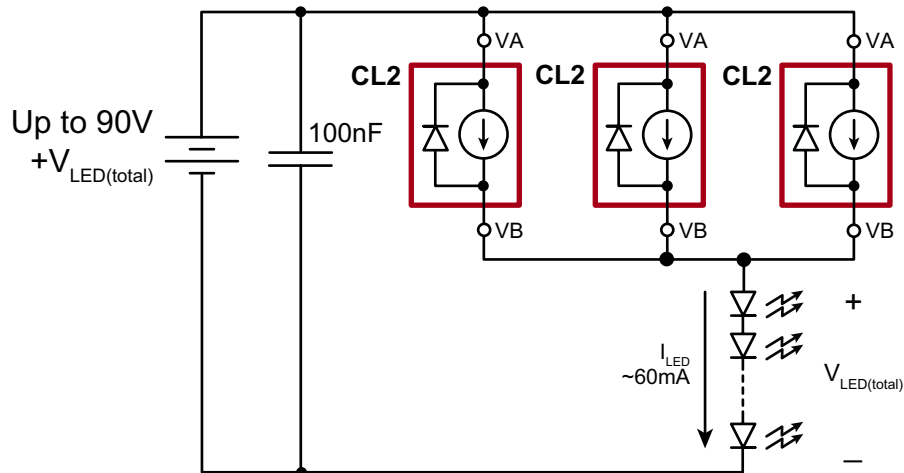

3-Lead TO-252 D-PAK Package Outline (K4)

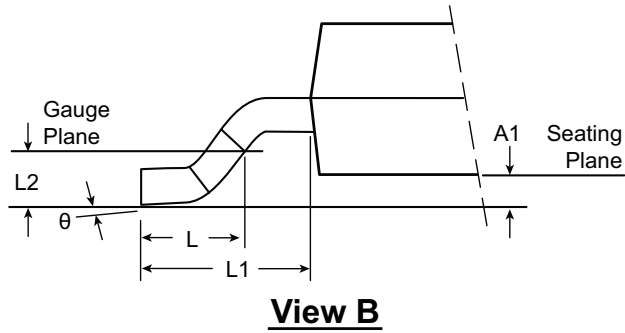
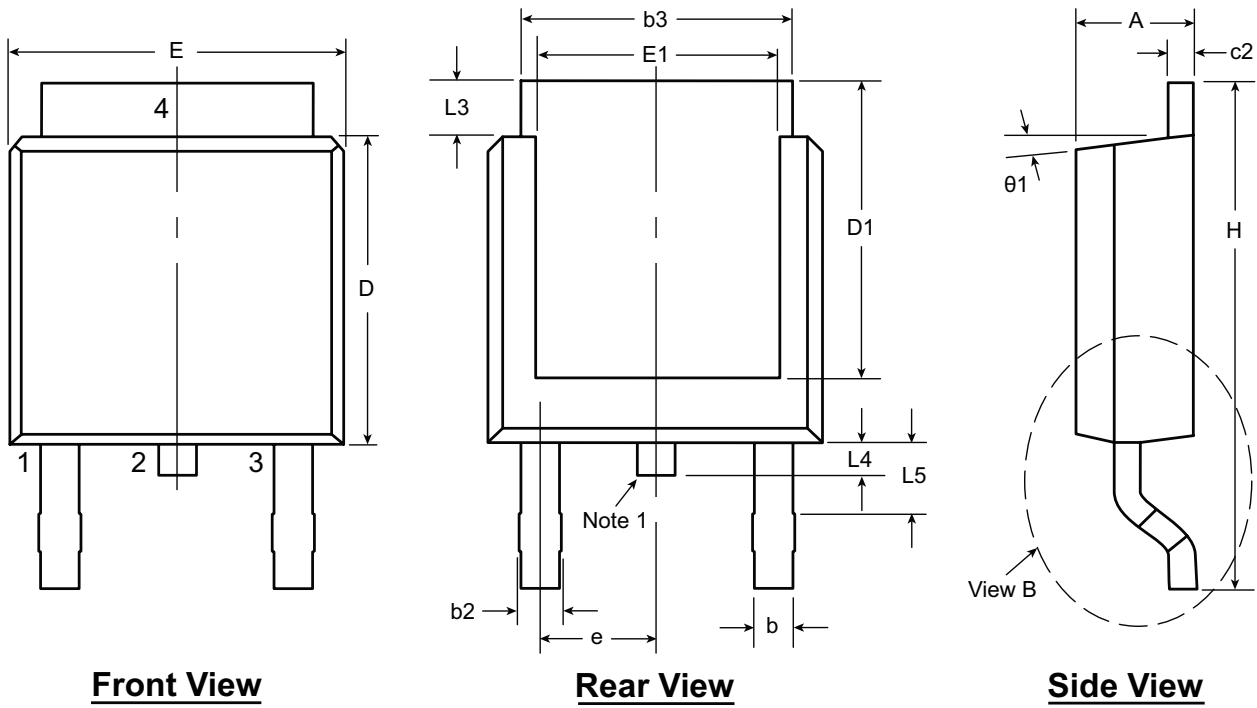

Note:
 1. Although 4 terminal locations are shown, only 3 are functional. Lead number 2 was removed.

Symbol	A	A1	b	b2	b3	c2	D	D1	E	E1	e	H	L	L1	L2	L3	L4	L5	θ	θ_1			
Dimension (inches)	MIN	.086	.000*	.025	.030	.195	.018	.235	.205	.250	.170	.090 BSC	.370	.055	.108 REF	.020 BSC	.035	.025*	.045	0°	0°		
	NOM	-	-	-	-	-	-	.240	-	-	-		-	.060			-	-	-	-	-	-	-
	MAX	.094	.005	.035	.045	.215	.035	.245	.217*	.265	.182*		.410	.070			.050	.040	.060	10°	15°		

JEDEC Registration TO-252, Variation AA, Issue E, June 2004.
 * This dimension is not specified in the JEDEC drawing.
Drawings not to scale.
 Supertex Doc. #: DSPD-3TO252K4, Version E041309.

3-Lead TO-92 Package Outline (N3)

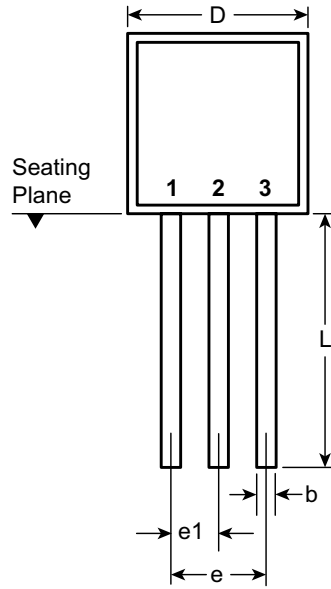

Front View

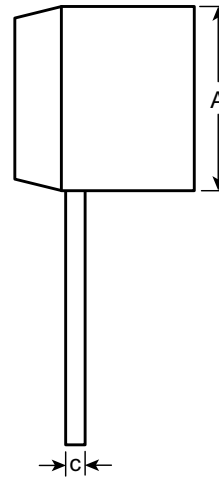

Side View

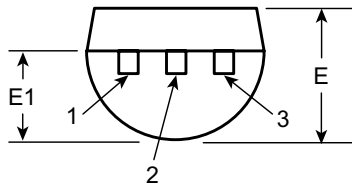

Bottom View

Symbol		A	b	c	D	E	E1	e	e1	L
Dimensions (inches)	MIN	.170	.014 [†]	.014 [†]	.175	.125	.080	.095	.045	.500
	NOM	-	-	-	-	-	-	-	-	-
	MAX	.210	.022 [†]	.022 [†]	.205	.165	.105	.105	.055	.610*

JEDEC Registration TO-92.

* This dimension is not specified in the JEDEC drawing.

† This dimension differs from the JEDEC drawing.

Drawings not to scale.

Supertex Doc.#: DSPD-3TO92N3, Version E041009.

3-Lead TO-243AA (SOT-89) Package Outline (N8)

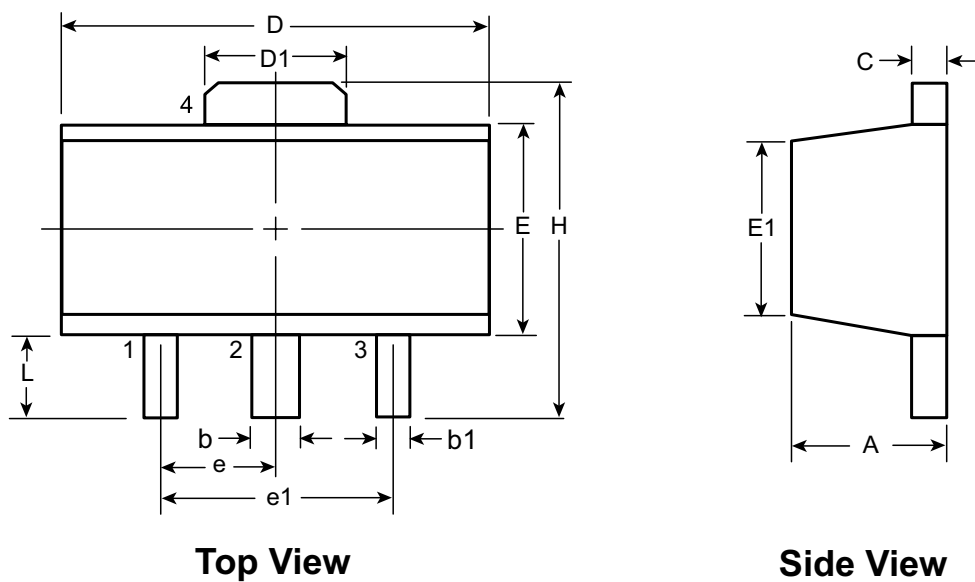

Symbol	A	b	b1	C	D	D1	E	E1	e	e1	H	L		
Dimensions (mm)	MIN	1.40	0.44	0.36	0.35	4.40	1.62	2.29	2.00 [†]	1.50 BSC	3.00 BSC	3.94	0.73 [†]	
	NOM	-	-	-	-	-	-	-	-			-	-	-
	MAX	1.60	0.56	0.48	0.44	4.60	1.83	2.60	2.29			-	-	4.25

JEDEC Registration TO-243, Variation AA, Issue C, July 1986.

[†] This dimension differs from the JEDEC drawing

Drawings not to scale.

Supertex Doc. #: DSPD-3TO243AAN8, Version F111010.

(The package drawings in this data sheet may not reflect the most current specifications. For the latest package outline information go to <http://www.supertex.com/packaging.html>.)

Supertex inc. does not recommend the use of its products in life support applications, and will not knowingly sell them for use in such applications unless it receives an adequate "product liability indemnification insurance agreement." **Supertex inc.** does not assume responsibility for use of devices described, and limits its liability to the replacement of the devices determined defective due to workmanship. No responsibility is assumed for possible omissions and inaccuracies. Circuitry and specifications are subject to change without notice. For the latest product specifications refer to the **Supertex inc.** (website: <http://www.supertex.com>)

Данный компонент на территории Российской Федерации

Вы можете приобрести в компании MosChip.

Для оперативного оформления запроса Вам необходимо перейти по данной ссылке:

<http://moschip.ru/get-element>

Вы можете разместить у нас заказ для любого Вашего проекта, будь то серийное производство или разработка единичного прибора.

В нашем ассортименте представлены ведущие мировые производители активных и пассивных электронных компонентов.

Нашей специализацией является поставка электронной компонентной базы двойного назначения, продукции таких производителей как XILINX, Intel (ex.ALTERA), Vicor, Microchip, Texas Instruments, Analog Devices, Mini-Circuits, Amphenol, Glenair.

Сотрудничество с глобальными дистрибьюторами электронных компонентов, предоставляет возможность заказывать и получать с международных складов практически любой перечень компонентов в оптимальные для Вас сроки.

На всех этапах разработки и производства наши партнеры могут получить квалифицированную поддержку опытных инженеров.

Система менеджмента качества компании отвечает требованиям в соответствии с ГОСТ Р ИСО 9001, ГОСТ РВ 0015-002 и ЭС РД 009

Офис по работе с юридическими лицами:

105318, г.Москва, ул.Щербаковская д.3, офис 1107, 1118, ДЦ «Щербаковский»

Телефон: +7 495 668-12-70 (многоканальный)

Факс: +7 495 668-12-70 (доб.304)

E-mail: info@moschip.ru

Skype отдела продаж:

moschip.ru

moschip.ru_4

moschip.ru_6

moschip.ru_9