



plus
WiFi click™

1. Introduction



WiFi PLUS Click is an accessory board in **mikroBUS™** form factor. It's a compact solution for adding WiFi communication to your device. It features **MRF24WB0MA** - 2.4GHz, IEEE std. 802.11 - compliant module as well as **MCW1001** companion controller with on-board TCP/IP stack and 802.11 connection manager. WiFi PLUS click communicates with target board via UART interface. Board is designed to use 3.3V power supply only. It has an option to achieve low power consumption.

2. Soldering the headers

Before using your click board, make sure to solder provided 1x8 male headers to both sides of the board. Two 1x8 male headers are included with the board in the package.



1

2



Turn the board upside down so that bottom side is facing you upwards. Place shorter parts of the header pins in both soldering pad locations.

3



Turn the board upward again. Make sure to align the headers so that they are perpendicular to the board, then solder the pins carefully.

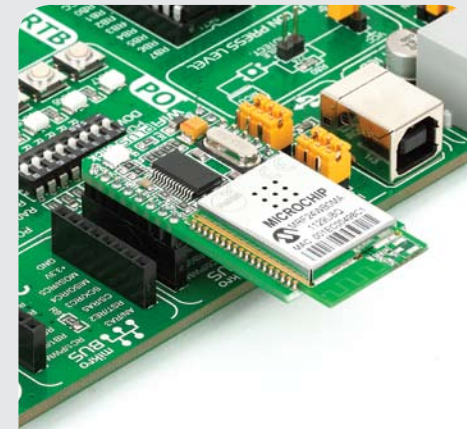

5. Essential features

The combination of the **MRF24WB0MA** and **MCW1001** results in support for IEEE Standard 802.11 and IP services. The **MRF24WB0MA** RF transceiver module contains integrated PCB antenna with range up to 400m. WiFi PLUS click does not use the memory resources of the target microcontroller for TCP/IP stack operations, which makes this module the best choice for using with wide range of different microcontrollers.

3. Plugging the board in

Once you have soldered the headers your board is ready to be placed into desired mikroBUS™ socket. Make sure to align the cut in the lower-right part of the board with the markings on the silkscreen at the mikroBUS™ socket. If all of the pins are aligned correctly, push the board all the way into the socket.

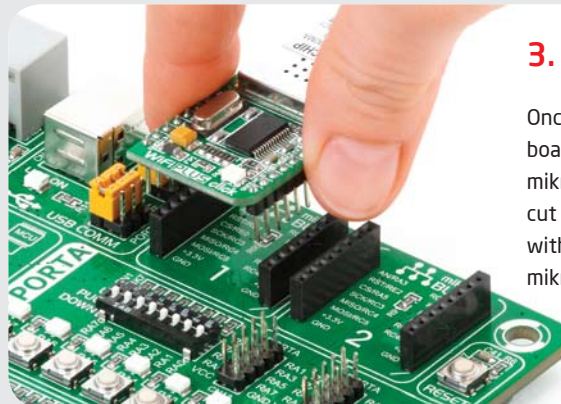

click™
BOARD
www.mikroe.com

WiFi Plus click Manual
ver. 1.01



0 10000 019054

6. WiFi plus click Board Schematics

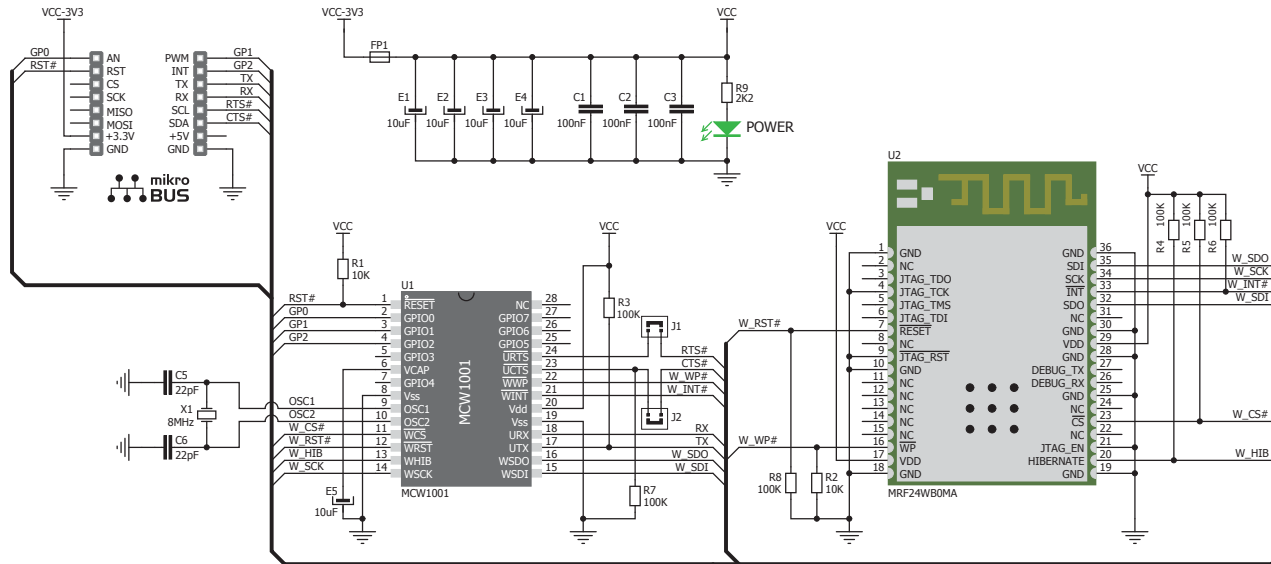

7. SMD Jumpers

Jumpers **J1** and **J2** connect **MCW1001** controller RTS and CTS lines to the SCL and SDA lines on mikroBUS™ host connector, respectively. Considering that all mikroBUS™ host connectors on a target board usually share the same I²C lines, these jumpers must not be soldered if you want to use SCL and SDA pins on other module in the same time. Jumpers J1 and J2 are not soldered by default.

8. Code Examples

Once you have done all the necessary preparations, it's time to get your click board up and running. We have provided the examples for mikroC, mikroBasic and mikroPascal compilers on our **Libstock** website. Just download them and you are ready to start.



9. Support

MikroElektronika offers **Free Tech Support** (www.mikroe.com/esupport) until the end of product lifetime, so if something goes wrong, we are ready and willing to help!

Данный компонент на территории Российской Федерации

Вы можете приобрести в компании MosChip.

Для оперативного оформления запроса Вам необходимо перейти по данной ссылке:

<http://moschip.ru/get-element>

Вы можете разместить у нас заказ для любого Вашего проекта, будь то серийное производство или разработка единичного прибора.

В нашем ассортименте представлены ведущие мировые производители активных и пассивных электронных компонентов.

Нашей специализацией является поставка электронной компонентной базы двойного назначения, продукции таких производителей как XILINX, Intel (ex.ALTERA), Vicor, Microchip, Texas Instruments, Analog Devices, Mini-Circuits, Amphenol, Glenair.

Сотрудничество с глобальными дистрибьюторами электронных компонентов, предоставляет возможность заказывать и получать с международных складов практически любой перечень компонентов в оптимальные для Вас сроки.

На всех этапах разработки и производства наши партнеры могут получить квалифицированную поддержку опытных инженеров.

Система менеджмента качества компании отвечает требованиям в соответствии с ГОСТ Р ИСО 9001, ГОСТ РВ 0015-002 и ЭС РД 009

Офис по работе с юридическими лицами:

105318, г.Москва, ул.Щербаковская д.3, офис 1107, 1118, ДЦ «Щербаковский»

Телефон: +7 495 668-12-70 (многоканальный)

Факс: +7 495 668-12-70 (доб.304)

E-mail: info@moschip.ru

Skype отдела продаж:

moschip.ru

moschip.ru_4

moschip.ru_6

moschip.ru_9