

## General Description

The MAX44267 evaluation kit (EV kit) provides a proven design to evaluate the MAX44267 Beyond-the-Rails™ precision, low-noise, low-drift, dual operational amplifier (op-amp) in a 14-pin TSSOP package. The EV kit circuit is preconfigured as noninverting amplifiers, but can be adapted to other topologies by changing a few components.

The EV kit comes with a MAX44267AUD+ installed.

## Features and Benefits

- Accommodate Multiple Op-Amp Configuration
- Up to  $\pm 12.5\text{V}$  with a Single Supply (+2.25V to +15V)
- True Zero Output from a Single Supply
- Proven PCB Layout
- Fully Assembled and Tested

*[Ordering Information](#) appears at end of data sheet.*

*Beyond-the-Rails is a trademark of Maxim Integrated Products, Inc.*

## Quick Start

### Required Equipment

- MAX44267 EV kit
- 12V DC power supply
- Two precision voltage sources
- Two digital multimeters (DMMs)

### Procedure

The EV kit is fully assembled and tested. Follow the steps below to verify board operation:

- 1) Verify that all jumpers (JU1–JU5) are in their default positions, as shown in [Table 1](#).
- 2) Connect the positive terminal of the +12V supply to the VDD test point and the negative terminal to the GND test point.
- 3) Connect the positive terminal of the precision voltage source to INAP test point. Connect the negative terminal of the precision voltage source to the GND test point. INAM is already connected to GND via JU1.
- 4) Connect the positive terminal of the second precision voltage source to the INBP test point. Connect the negative terminal of the precision voltage source to the GND test point. INBM is already connected to GND via JU3.
- 5) Connect the DMMs to monitor the voltages on OUTA and OUTB test points. With the 10k $\Omega$  feedback resistors and 1k $\Omega$  series resistors, the gain of the noninverting amplifier is +11V/V.
- 6) Turn on the power supply.
- 7) Set the precision voltage sources to 100mV and enable. Observe the output at OUTA and OUTB on the DMMs. Both should read approximately +1.1V.
- 8) Disable the precision voltage sources and supply.
- 9) Remove shunts from JU1 and JU3, and install shunts on jumper JU2 and JU4. The gain of the inverting amplifier is -10V/V.
- 10) Apply each precision voltage source to INAM and INBM test points.
- 11) Enable the precision voltage sources. Observe the output at OUTA and OUTB on the DMMs. Both should read approximately -1.0V.

## Detailed Description of Hardware

The MAX44267 precision, low-noise, low-drift dual operational amplifier offers true-zero output that allows the output to cross zero and maximize the dynamic range of an ADC and increase resolution.

### Op Amp Configurations

The MAX44267 is a single-supply, dual op amp that is ideal for differential sensing, noninverting amplification, buffering, and filtering. A few common configurations are shown in the next few sections.

The following sections explain how to configure one of the device's op amps (op amp A). To configure the device's second op amp (op amp B), the same equations can be used after modifying the component reference designators.

#### Noninverting Configuration

The MAX44267 EV kit comes preconfigured as a noninverting amplifier. The gain is set by the ratio of R5 and R1. The MAX44267 EV kit comes preconfigured for a gain of +11V/V. The output voltage for the noninverting configuration is given by the equation below:

$$V_{OUTA} = \left(1 + \frac{R5}{R1}\right) [V_{INAP} \pm V_{OS}]$$

#### Inverting Configuration

To configure the EV kit as an inverting amplifier, remove the shunt on JU1 and install a shunt on jumper JU2 and feed an input signal on the INAM pad.

#### Differential Amplifier

To configure the MAX44267 EV kit as a differential amplifier, replace R1, R2, R3, and R5 with appropriate resistors. When R1 = R2 and R3 = R5, the CMRR of the differential amplifier is determined by the matching of the resistor ratios R1/R2 and R3/R5.

$$V_{OUTA} = A_V (V_{INAP} - V_{INAM})$$

where the gain is:

$$A_V = \frac{R5}{R1} = \frac{R3}{R2}$$

#### Sallen-Key Configuration

The Sallen-Key topology is ideal for filtering sensor signals with a second-order filter and acting as a buffer. Schematic complexity is reduced by combining the

filter and buffer operations. The MAX44267 EV kit can be configured in a Sallen-Key topology by replacing and populating a few components. The Sallen-Key topology can be configured as a unity-gain buffer by replacing R5 with a 0Ω resistor and removing resistor R1. The signal is noninverting and applied to INAP. The filter component pads are R2–R4 and R8, where some have to be populated with resistors and others with capacitors.

**Lowpass Filter:** To configure the Sallen-Key as a low-pass filter, remove jumper JU1, populate the R2 and R8 pads with resistors and populate the R3 and R4 pads with capacitors. The corner frequency and Q are then given by:

$$f_C = \frac{1}{2\pi\sqrt{R_{R2}R_{R8}C_{R3}C_{R4}}}$$

$$Q = \frac{\sqrt{R_{R2}R_{R8}C_{R3}C_{R4}}}{C_{R3}(R_{R2} + R_{R8})}$$

**Highpass Filter:** To configure the Sallen-Key as a high-pass filter, remove jumper JU1, populate the R3 and R4 pads with resistors and populate the R2 and R8 pads with capacitors. The corner frequency and Q are then given by:

$$f_C = \frac{1}{2\pi\sqrt{R_{R3}R_{R4}C_{R2}C_{R8}}}$$

$$Q = \frac{\sqrt{R_{R3}R_{R4}C_{R2}C_{R8}}}{R_{R4}(C_{R2} + C_{R8})}$$

**Bandpass Filter:** To configure the Sallen-Key as a band-pass filter, remove jumper JU1, replace R8, populate R3 and R4 pads with resistors and populate C8 and R2 pads with capacitors. The corner frequency and Q are then given by:

$$f_C = \frac{1}{2\pi\sqrt{\frac{R_{R4} + R_{R8}}{C_{C8}C_{R2}R_{R8}R_{R3}R_{R4}}}}$$

$$Q = \frac{\sqrt{(R_{R4} + R_{R8})C_{C8}C_{R2}R_{R8}R_{R3}R_{R4}}}{R_{R4}R_{R8}(C_{C8} + C_{R2}) + R_{R3}C_{R2}\left(R_{R4} - \frac{R_{R5}}{R_{R1}}R_{R8}\right)}$$

**Transimpedance Amplifier**

To configure the MAX44267 EV kit as a transimpedance amplifier (TIA), place a shunt on jumper JU2, replace R1 and R2 with a 0Ω resistor. The output voltage of the TIA is the input current multiplied by the feedback resistor:

$$V_{OUTA} = -(I_{INAP} + I_{BIAS}) \times R_{R5} \pm V_{OS}$$

where:

$I_{INAP}$  is the input current source applied at the INAP test point

$I_{BIAS}$  is the input bias current

$V_{OS}$  is the input offset voltage of the op amp

Use a capacitor at location R16 or R17 (and C8, if applicable) to stabilize the op amp by rolling off high-frequency gain due to a large cable capacitance.

**Capacitive Loads**

Some applications require driving large capacitive loads. The EV kit provides C8 and R6 pads for optional capacitive-load driving circuit. C8 simulates the capacitive load while R6 acts as isolation resistor to improve the op amp’s stability at higher capacitive loads. To improve the stability of the amplifier in such cases, replace R6 with a suitable resistor value to improve amplifier phase margin.

**Table 1. MAX44267 EV Kit Jumper Description**

JUMPER	SHUNT POSITION	DESCRIPTION
JU1	Not Installed	Disconnects INAM from GND
	Installed*	Connects INA- to GND through R1 for <b>noninverting</b> configuration
JU2	Not Installed*	Disconnects INAP from GND
	Installed	Connects INA+ to GND through R2
JU3	Not Installed	Disconnects INBM from GND
	Installed*	Connects INB- to GND through R9 for noninverting configuration
JU4	Not Installed*	Disconnects INBP from GND
	Installed	Connects INB+ to GND through R10
JU5	Not Installed	Disconnects CPVDD from VDD
	Installed*	Connects CPVDD to VDD

\*Default position.

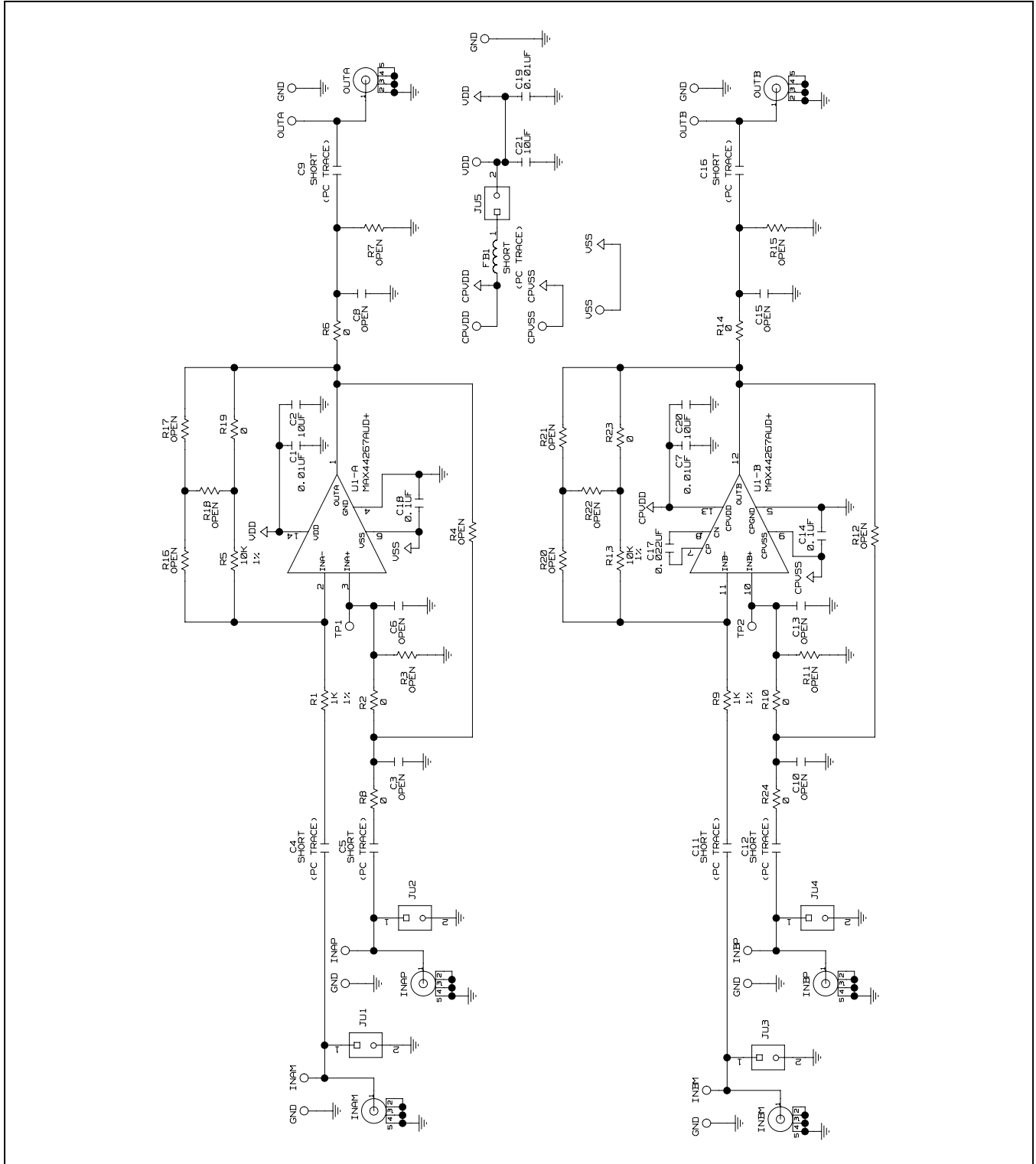

Figure 1. MAX44267 EV Kit Schematic

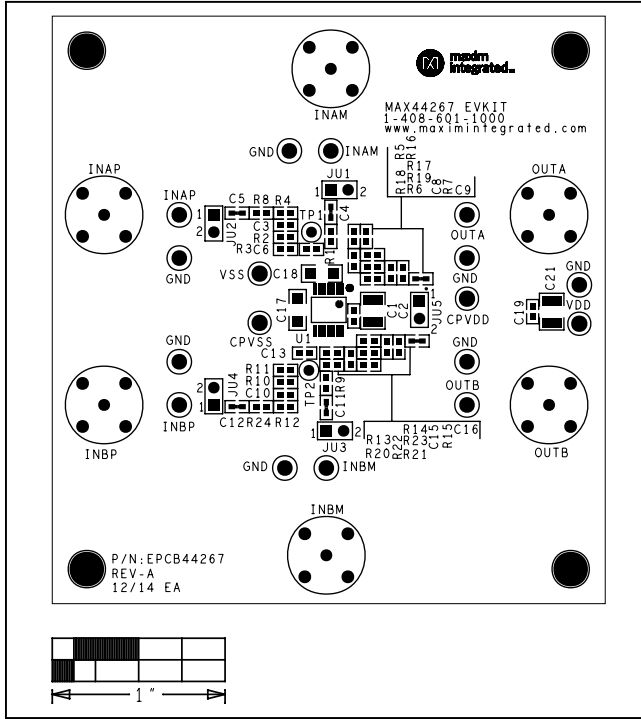

Figure 2. MAX44267 EV Kit Component Placement Guide—Component Side

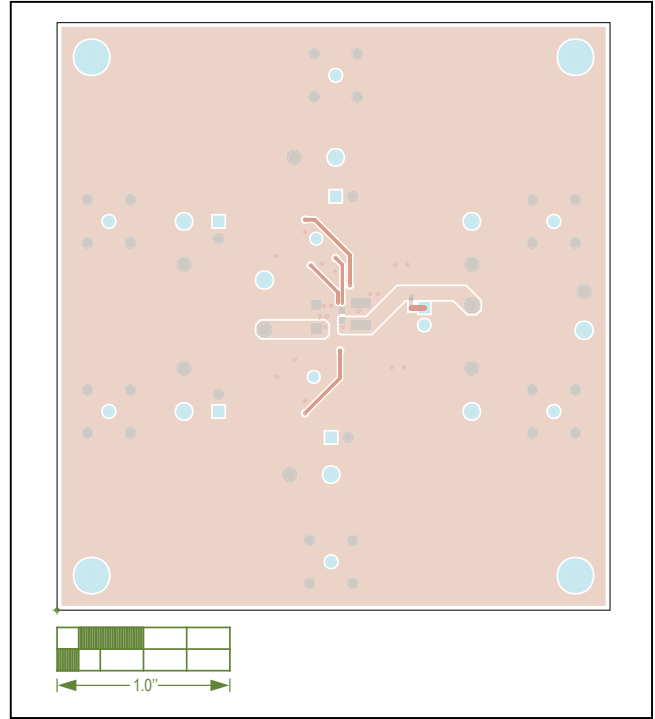

Figure 4. MAX44267 EV Kit PCB Layout—Solder Side

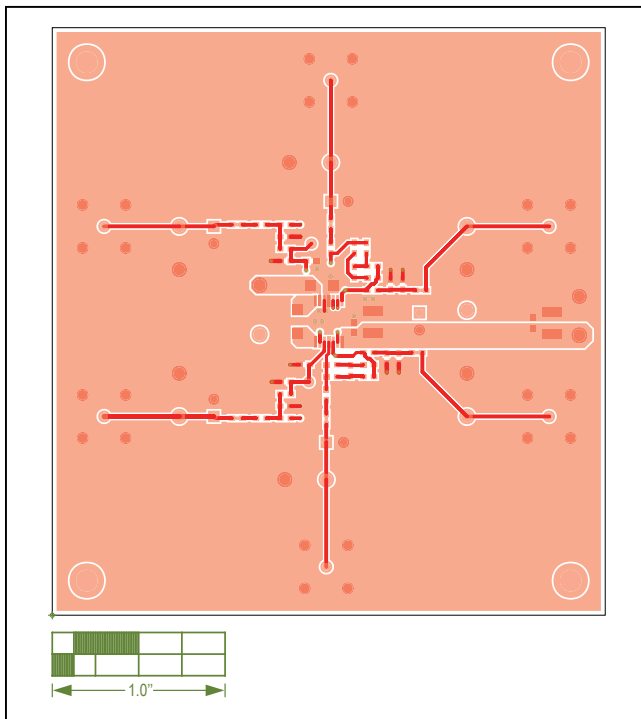

Figure 3. MAX44267 EV Kit PCB Layout—Component Side

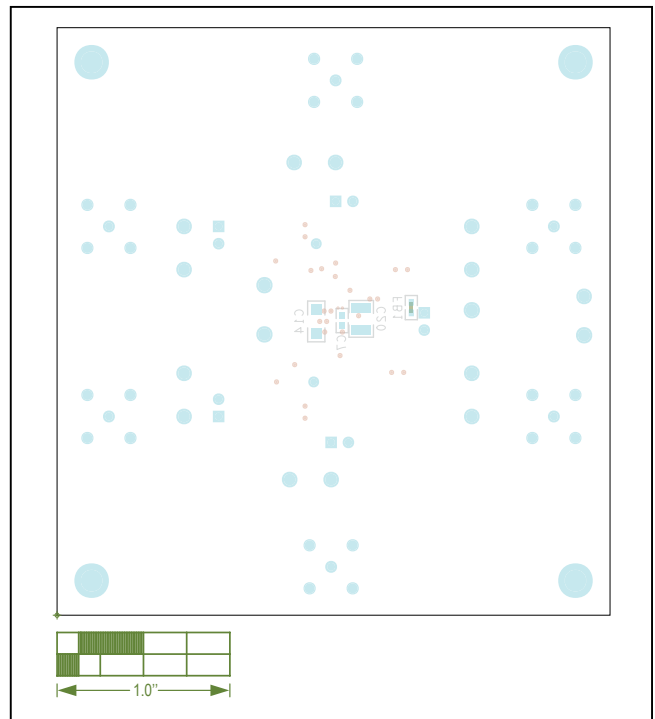

Figure 5. MAX44267 EV Kit Component Placement Guide—Solder Side

### Component List

Refer to the file "[evkit\\_bom\\_max44267\\_evkit\\_a.csv](#)" attached to this data sheet for component information.

### Ordering Information

PART	TYPE
MAX44267EVKIT#	EV Kit

*#Denotes RoHS compliant.*

### Revision History

REVISION NUMBER	REVISION DATE	DESCRIPTION	PAGES CHANGED
0	2/15	Initial release	—

For pricing, delivery, and ordering information, please contact Maxim Direct at 1-888-629-4642, or visit Maxim Integrated's website at [www.maximintegrated.com](http://www.maximintegrated.com).

*Maxim Integrated cannot assume responsibility for use of any circuitry other than circuitry entirely embodied in a Maxim Integrated product. No circuit patent licenses are implied. Maxim Integrated reserves the right to change the circuitry and specifications without notice at any time.*

## Данный компонент на территории Российской Федерации

### Вы можете приобрести в компании MosChip.

Для оперативного оформления запроса Вам необходимо перейти по данной ссылке:

<http://moschip.ru/get-element>

Вы можете разместить у нас заказ для любого Вашего проекта, будь то серийное производство или разработка единичного прибора.

В нашем ассортименте представлены ведущие мировые производители активных и пассивных электронных компонентов.

Нашей специализацией является поставка электронной компонентной базы двойного назначения, продукции таких производителей как XILINX, Intel (ex.ALTERA), Vicor, Microchip, Texas Instruments, Analog Devices, Mini-Circuits, Amphenol, Glenair.

Сотрудничество с глобальными дистрибьюторами электронных компонентов, предоставляет возможность заказывать и получать с международных складов практически любой перечень компонентов в оптимальные для Вас сроки.

На всех этапах разработки и производства наши партнеры могут получить квалифицированную поддержку опытных инженеров.

Система менеджмента качества компании отвечает требованиям в соответствии с ГОСТ Р ИСО 9001, ГОСТ РВ 0015-002 и ЭС РД 009

### Офис по работе с юридическими лицами:

105318, г.Москва, ул.Щербаковская д.3, офис 1107, 1118, ДЦ «Щербаковский»

Телефон: +7 495 668-12-70 (многоканальный)

Факс: +7 495 668-12-70 (доб.304)

E-mail: [info@moschip.ru](mailto:info@moschip.ru)

Skype отдела продаж:

moschip.ru

moschip.ru\_4

moschip.ru\_6

moschip.ru\_9