

# Wireless Charging Coil Assembly

AWCCA 53N53



RoHS / RoHS II Compliant



53 x 53mm

Moisture Sensitivity Level (MSL) – MSL = 1

## FEATURES:

- Wireless Charging Transmitter or Receiver single Coil, with (6.3  $\mu$ H & 24 $\mu$ H options).
- Outline Dimensions: 53mm x 53mm x 5.0mm.
- For Tx or Rx Applications.
- High permeability shielding to protect sensitive electronics
- Durable construction
- RoHS / RoHS II Compliant & Pb free

## APPLICATIONS:

- Automotive Industry (in car charging)
- Batteries and Battery Chargers
- Consumer Electronics
- Smart Watches
- Digital Cameras and Camcorders
- Wireless Charging Stations
- Mobile Phones & Charging Accessories
- Power Supplies
- Power Tool Manufacturers

## STANDARD SPECIFICATIONS

### Maximum Ratings

Item	Value
Operating Temperature Range	-25°C to + 85°C RH $\leq$ 90%.
Storage Temperature Range	-25°C to +85°C, 70% RH (Max.)

### Electrical Characteristics

Part Number	Inductance	Q-Factor	Current Rating (rms)	Saturated Current (rms)	DC Resistance	SRF
AWCCA-53N53H50-C01-B	24 $\mu$ H $\pm$ 10%	170 $\pm$ 30%	5.7A Typ.	30A	72m $\Omega$ $\pm$ 20%	2.8MHz
AWCCA-53N53H50-C02-B	6.3 $\mu$ H $\pm$ 10%	66 $\pm$ 30%	11A Typ.	40A	19m $\Omega$ $\pm$ 20%	6.4MHz
Test Condition	100KHz / 1V	100KHz/1V	$\Delta$ T = 40 K	100KHz/1V	20 $\pm$ 15°C	
Test Environment	Ambient Temperature: 20 $\pm$ 15°C, RH: 65% $\pm$ 20%.					

### Test Conditions

A) - Ambient Temperature: 20 $\pm$ 15°C, RH: 65%  $\pm$ 20%.

If any doubt on the results, measurements/tests should be made within the following limits: Ambient Temperature: 20 $\pm$ 2°C, RH: 65% $\pm$ 5%

B) - Isat: DC current at which the inductance drops approximate 5% from its value without current.

## PART IDENTIFICATION:

AWCCA-53N53- **H50** - **C** - **0X** - **B**

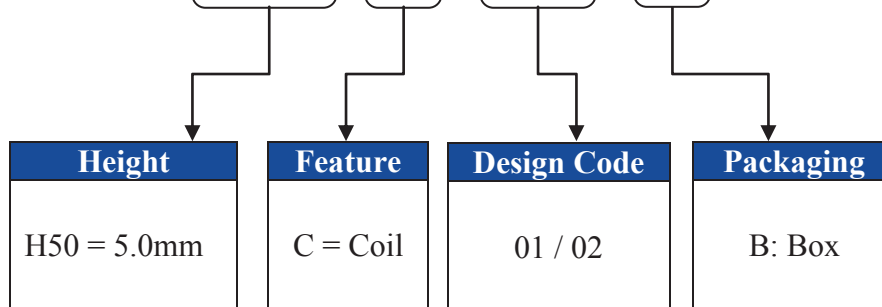

# Wireless Charging Coil Assembly

AWCCA 53N53



RoHS / RoHS II Compliant



53 x 53mm

## OUTLINE DIMENSIONS:

Out Line Dimensions (unit mm)

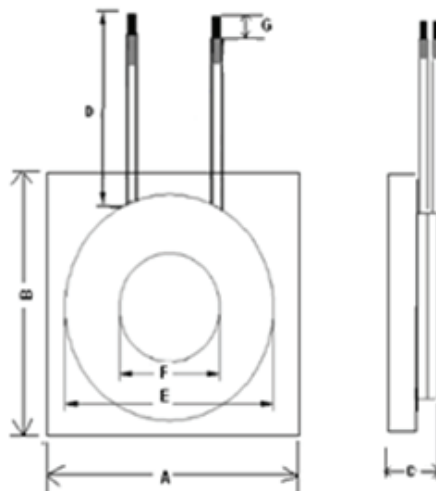

Part Number	A	B	C	D	E	F	G
AWCCA-53N53H50-C0X-B	53±1	53±1	5.0±0.5	50±3	44 Max	20.5±0.5	5.0±2

## Winding Specifications

Nominal Code	Number of Coils	Wire	Number of Turns	Inductance
C01	1	φ 0.08×105	20	24μH ±10%
C02	1	φ 0.08×105	10	6.3μH ±10%

## Product Customization

Products can be customized according to the Wireless Charging Coil Standards or to customer requirements. Please refer to the following table for the feature ranges, and contact ABRACON or authorized distributor / agent for further details.

Inductance Range [μH]	DC Resistance Range [mΩ]	Dimension Range [mm]	Thickness range [mm]
1 ~ 100	10 ~ 1000	10 ~ 200	0.4 ~ 10

**Manual Soldering:** 350°C Max, 3secs

### Storage condition

- Recommended storage conditions: -25°C~85°C, 70%RH (Max.)
- Service life: Within the limits of six month from being produced.
- The appearance and solder ability should be check, if product is not in expiry date.

### Operation Conditions

- Use condition limit: T=-25°C ~ 85°C, RH≤ 90%.

**ATTENTION:** Abracon Corporation's products are COTS – Commercial-Off-The-Shelf products; suitable for Commercial, Industrial and, where designated, Automotive Applications. Abracon's products are not specifically designed for Military, Aviation, Aerospace, Life-dependant Medical applications or any application requiring high reliability where component failure could result in loss of life and/or property. For applications requiring high reliability and/or presenting an extreme operating environment, written consent and authorization from Abracon Corporation is required. Please contact Abracon Corporation for more information.

ABRACON IS  
ISO9001:2008  
CERTIFIED



Visit [www.abracon.com](http://www.abracon.com) for Terms & Conditions of Sale **Revised: 12.08.13**  
30332 Esperanza, Rancho Santa Margarita, California 92688  
tel 949-546-8000 | fax 949-546-8001 | [www.abracon.com](http://www.abracon.com)

## Данный компонент на территории Российской Федерации

### Вы можете приобрести в компании MosChip.

Для оперативного оформления запроса Вам необходимо перейти по данной ссылке:

<http://moschip.ru/get-element>

Вы можете разместить у нас заказ для любого Вашего проекта, будь то серийное производство или разработка единичного прибора.

В нашем ассортименте представлены ведущие мировые производители активных и пассивных электронных компонентов.

Нашей специализацией является поставка электронной компонентной базы двойного назначения, продукции таких производителей как XILINX, Intel (ex.ALTERA), Vicor, Microchip, Texas Instruments, Analog Devices, Mini-Circuits, Amphenol, Glenair.

Сотрудничество с глобальными дистрибьюторами электронных компонентов, предоставляет возможность заказывать и получать с международных складов практически любой перечень компонентов в оптимальные для Вас сроки.

На всех этапах разработки и производства наши партнеры могут получить квалифицированную поддержку опытных инженеров.

Система менеджмента качества компании отвечает требованиям в соответствии с ГОСТ Р ИСО 9001, ГОСТ РВ 0015-002 и ЭС РД 009

### Офис по работе с юридическими лицами:

105318, г.Москва, ул.Щербаковская д.3, офис 1107, 1118, ДЦ «Щербаковский»

Телефон: +7 495 668-12-70 (многоканальный)

Факс: +7 495 668-12-70 (доб.304)

E-mail: [info@moschip.ru](mailto:info@moschip.ru)

Skype отдела продаж:

moschip.ru

moschip.ru\_4

moschip.ru\_6

moschip.ru\_9