

# VSC3312-01

## 8.5 Gbps 12x12 Crosspoint Switch

The VSC3312-01 is a 12-port 8.5 Gbps asynchronous switch with advanced signal equalization designed for high-speed serial backplanes and cable interconnect applications. VSC3312-01 switches allow multicast, loopback, and reconfigurable Input/Output (I/O) capability for great flexibility in allocating and routing signals in a broad range of applications. The VSC3312-01 includes dual time-constant equalization, which significantly reduces jitter associated with driving multigigabit signals across backplanes and cables. A fully asynchronous architecture allows any data rate or protocol on any channel without the need for an external reference clock. This gives the VSC3312-01 wire-like interoperability in virtually any application that uses binary signaling. The VSC3312-01 can also be used as a buffer that simplifies and enhances the design of high-speed signal paths by providing signal equalization at both inputs and outputs to reduce or reverse signal degradation due to transmission line effects.

The VSC3312-01 has a total of 24 ports. Eight are dedicated inputs, eight are dedicated outputs, and the remaining eight may be configured as either inputs or outputs without restriction. This design provides the flexibility of using the device as a standard 12x12 crosspoint, or any ratio from 8x16 to 16x8. This unique feature allows full I/O utilization in any application that has less than a 2:1 ratio between inputs and outputs. In many cases, this translates to a significant reduction in chip count. Featuring programmable input signal equalization and output pre-emphasis, each with multiple time constants, the VSC3312-01 is also ideal for countering signal degradation over a wide variety of transmission media types and lengths.

Typical power consumption for the device is 160 mW per active channel, and unused channels may be deactivated to save the power associated with those ports. The output drivers for the VSC3312-01 also feature a wide supply voltage range (from 1.8 V to 3.3 V) that allows flexibility in matching the output swing to application requirements.

The VSC3312-01 has a LOS detector with programmable thresholds on every input port. The LOS status can be made to appear at either of two status pins for external use. The LOS signal can also be switched to each of the outputs in concert with the high-speed switching core. LOS forwarding can be enabled for each of the outputs, which will cause the outputs to be squelched in response to a LOS detect at the corresponding input, thereby propagating signal envelopes through the switch.

Programming of the VSC3312-01 is through a standard two-wire serial interface. The interface address can be hardwired through static pins or through a proprietary two-pin interface that allows for address selection after power-up. All pin functions such as Config, ResetB, and Status pin states are also accessible through registers to ensure maximum flexibility.

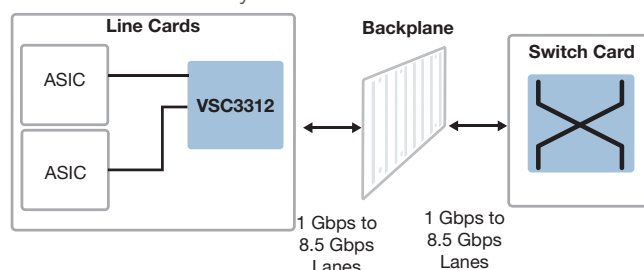

### Applications

- Wideband signal switching and clean-up
- Line driver or receiver
- Backplane signal fanout, driver, or receiver
- Copper cable driver or receiver
- PCB signal enhancement

### Specifications

- 8.5 Gbps non-return-to-zero (NRZ) per-channel data rate
- 2.5 V core, 1.8 V, 2.5 V, and 3.3 V high-speed I/O
- 3.2 W maximum at 3.3 V, or 2.4 W at 2.5 V, or 2 W at 1.8 V

# VSC3312-01

## 8.5 Gbps 12x12 Crosspoint Switch

### Features

- 8.5 Gbps NRZ data bandwidth
- Fully non-blocking and multicasting switch core with per-pin signal inversion capability
- Multiple time-constant programmable input and output equalization
- Wide equalization adjustment range
- Fully asynchronous operation with <1 ns latency
- Reconfigurable I/O capability
- LOS detection and forwarding

### Benefits

- Transparent support for virtually all data rates and protocols
- Allows complete flexibility in routing and distributing signals
- Compensates for multiple impairments in a signal path
- Supports all types of interconnect media: PCB, backplanes, and cable
- No adjustments based on data rate or reference clock required
- Customize the I/O to the application
- OOB forwarding for protocols like SAS and SATA

### Related Products

Visit [www.microsemi.com](http://www.microsemi.com) for information about other related products.

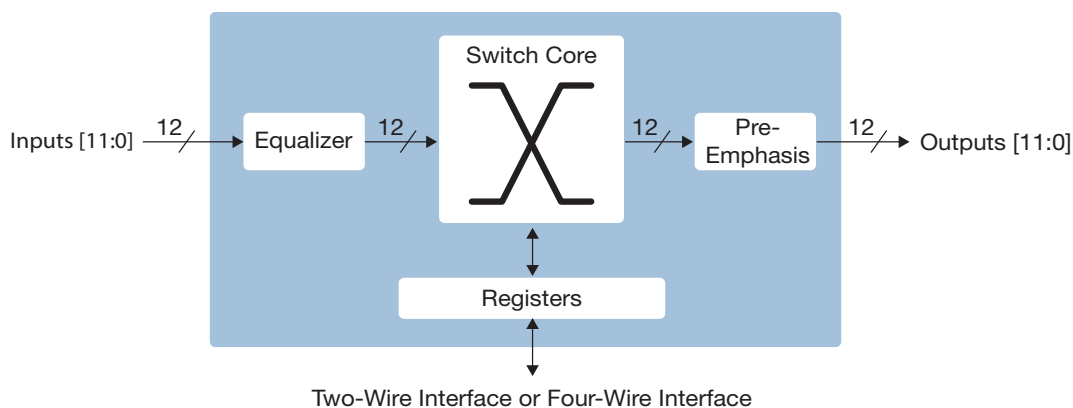

**Microsemi Corporate Headquarters**  
 One Enterprise, Aliso Viejo, CA 92656 USA  
 Within the USA: +1 (800) 713-4113  
 Outside the USA: +1 (949) 380-6100  
 Sales: +1 (949) 380-6136  
 Fax: +1 (949) 215-4996  
 email: [sales.support@microsemi.com](mailto:sales.support@microsemi.com)  
[www.microsemi.com](http://www.microsemi.com)

Microsemi Corporation (Nasdaq: MSCC) offers a comprehensive portfolio of semiconductor and system solutions for communications, defense and security, aerospace, and industrial markets. Products include high-performance and radiation-hardened analog mixed-signal integrated circuits, FPGAs, SoCs, and ASICs; power management products; timing and synchronization devices and precise time solutions; voice processing devices; RF solutions; discrete components; enterprise storage and communications solutions, security technologies, and scalable anti-tamper products; Ethernet solutions; Power-over-Ethernet ICs and midspans; custom design capabilities and services. Microsemi is headquartered in Aliso Viejo, California, and has approximately 4,800 employees worldwide. Learn more at [www.microsemi.com](http://www.microsemi.com).

## Данный компонент на территории Российской Федерации

### Вы можете приобрести в компании MosChip.

Для оперативного оформления запроса Вам необходимо перейти по данной ссылке:

<http://moschip.ru/get-element>

Вы можете разместить у нас заказ для любого Вашего проекта, будь то серийное производство или разработка единичного прибора.

В нашем ассортименте представлены ведущие мировые производители активных и пассивных электронных компонентов.

Нашей специализацией является поставка электронной компонентной базы двойного назначения, продукции таких производителей как XILINX, Intel (ex.ALTERA), Vicor, Microchip, Texas Instruments, Analog Devices, Mini-Circuits, Amphenol, Glenair.

Сотрудничество с глобальными дистрибьюторами электронных компонентов, предоставляет возможность заказывать и получать с международных складов практически любой перечень компонентов в оптимальные для Вас сроки.

На всех этапах разработки и производства наши партнеры могут получить квалифицированную поддержку опытных инженеров.

Система менеджмента качества компании отвечает требованиям в соответствии с ГОСТ Р ИСО 9001, ГОСТ РВ 0015-002 и ЭС РД 009

### Офис по работе с юридическими лицами:

105318, г.Москва, ул.Щербаковская д.3, офис 1107, 1118, ДЦ «Щербаковский»

Телефон: +7 495 668-12-70 (многоканальный)

Факс: +7 495 668-12-70 (доб.304)

E-mail: [info@moschip.ru](mailto:info@moschip.ru)

Skype отдела продаж:

moschip.ru

moschip.ru\_4

moschip.ru\_6

moschip.ru\_9