

High Efficiency Step-Up LED Driver with Dual Output LCD Bias Power

Features

- Wide input range: 3.0V~5.5V
- Low quiescent current
- Drive up to 10 series LEDs or 2 parallel strings of 8 series LEDs
 - ▶ Backlight efficiency: up to 86%
 - ▶ Integrated 40V Power MOSFET
 - ▶ Flexible dimming control
 - 256-step I²C Controlled or
 - High resolution PWM 5~100kHz
 - ▶ High accuracy across full load range
 - ▶ Programmable LED open-circuit (OVP)/Short protection
 - ▶ Low 200mV feedback voltage
 - ▶ Internal over voltage protection (default 36V)
- Programmable dual Bias output regulator based on single inductor solution
 - ▶ Charge pump PFM mode at light load
 - ▶ LCD Bias efficiency: up to 90%
 - ▶ Wide dual output voltage range
 - +/-4.0V to +/-6.3V (100mV/step)
 - ▶ +/-1.5% V_{POS}/V_{NEG} output voltage accuracy
 - ▶ Maximum peak output current up to 80mA
 - ▶ Active output discharge function
 - ▶ Cycle-by-cycle inductor current limit
- 1 μ A shutdown current
- Pb-free Package: WLCSP-18
- -40°C to +85°C Temperature Range

Applications

- Smartphone/Tablet Backlight
- Netbook/Notebook Backlight
- PDA/GPS Backlight
- Portable Media Player

Brief Description

The KTZ8850 is a multifunction power management IC combining a high efficiency step-up LED driver with dual output LCD bias power regulator. It features a versatile constant current LED driver with a high efficiency DC-DC step up “boost” converter architecture. The low-side 40V power MOSFET is integrated in the device, minimizing the total number of external components. Unique technology and high 1.3A current limit allow KTZ8850 to drive up to 36V output (single string of 10 LEDs in series or 2 parallel strings of 8 LEDs in series).

The optimized 1.1MHz switching frequency results in small external component size. The driver is equipped with an internal decoder that allows digital FB control dimming for 256-step (8-bit) current programming and can be used for dimming via I²C interface.

High resolution PWM dimming control is also included for extended dimming range. For power savings, the PWM pin can be used for Content Adaptive Brightness Control (CABC) schemes.

Various protection features are built into the KTZ8850, including cycle-by-cycle input current limit protection, LED open-circuit (output over voltage) protection and thermal shutdown protection. The leakage current in shutdown mode is less than 1 μ A.

An LDO and a charge pump generate dual outputs at +5V (default) and -5V (default), whose voltages can be programmed via an I²C interface. By integrating synchronous rectification MOSFETs for the step-up converter and charge pump, the KTZ8850 maximizes conversion efficiency up to 90%.

The device integrates compensation and soft-start circuitry, which results in a simpler and smaller solution with much fewer external components. High switching frequency (2.2MHz) allows the use of a smaller inductor and capacitor to further reduce the solution size.

The I²C-compatible interface controls the dual output voltages and accesses the programmable functions and registers on the device.

KTZ8850 is available in a RoHS compliant 18-ball 2.47 x 1.27mm WLCSP package.

Ordering Information

Part Number	Marking ¹	Operating Temperature	Package	Functions	
				Backlight	Dual Output
KTZ8850EUC-TR	JFYZZ	-40°C to +85°C	WLCSP-18	1P10S/2P8S	±5V (default)

1. "YYZZ" is the date code and assembly code.

Typical Application

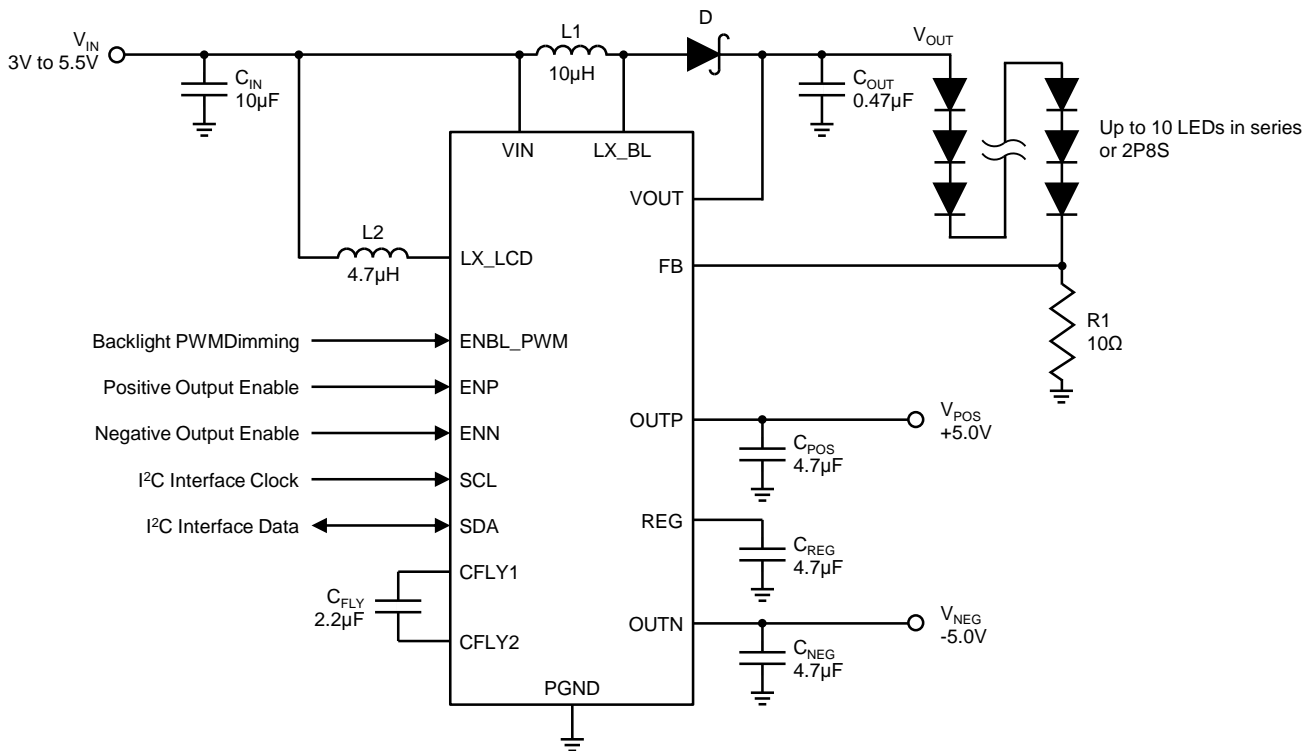

Figure 1. Typical Application Circuit for I²C Interface Control

Kinetic Technologies cannot assume responsibility for use of any circuitry other than circuitry entirely embodied in a Kinetic Technologies product. No intellectual property or circuit patent licenses are implied. Kinetic Technologies reserves the right to change the circuitry and specifications without notice at any time.

Данный компонент на территории Российской Федерации

Вы можете приобрести в компании MosChip.

Для оперативного оформления запроса Вам необходимо перейти по данной ссылке:

<http://moschip.ru/get-element>

Вы можете разместить у нас заказ для любого Вашего проекта, будь то серийное производство или разработка единичного прибора.

В нашем ассортименте представлены ведущие мировые производители активных и пассивных электронных компонентов.

Нашей специализацией является поставка электронной компонентной базы двойного назначения, продукции таких производителей как XILINX, Intel (ex.ALTERA), Vicor, Microchip, Texas Instruments, Analog Devices, Mini-Circuits, Amphenol, Glenair.

Сотрудничество с глобальными дистрибьюторами электронных компонентов, предоставляет возможность заказывать и получать с международных складов практически любой перечень компонентов в оптимальные для Вас сроки.

На всех этапах разработки и производства наши партнеры могут получить квалифицированную поддержку опытных инженеров.

Система менеджмента качества компании отвечает требованиям в соответствии с ГОСТ Р ИСО 9001, ГОСТ РВ 0015-002 и ЭС РД 009

Офис по работе с юридическими лицами:

105318, г.Москва, ул.Щербаковская д.3, офис 1107, 1118, ДЦ «Щербаковский»

Телефон: +7 495 668-12-70 (многоканальный)

Факс: +7 495 668-12-70 (доб.304)

E-mail: info@moschip.ru

Skype отдела продаж:

moschip.ru

moschip.ru_4

moschip.ru_6

moschip.ru_9