

# Si4421 Universal ISM Band FSK Transceiver

## DESCRIPTION

Silicon Labs' Si4421 is a single chip, low power, multi-channel FSK transceiver designed for use in applications requiring FCC or ETSI conformance for unlicensed use in the 433, 868 and 915 MHz bands. The Si4421 transceiver is a part of Silicon Labs' EZRadio™ product line, which produces a flexible, low cost, and highly integrated solution that does not require production alignments. The chip is a complete analog RF and baseband transceiver including a multi-band PLL synthesizer with PA, LNA, I/Q down converter mixers, baseband filters and amplifiers, and an I/Q demodulator. All required RF functions are integrated. Only an external crystal and bypass filtering are needed for operation.

The Si4421 features a completely integrated PLL for easy RF design, and its rapid settling time allows for fast frequency-hopping, bypassing multipath fading and interference to achieve robust wireless links. The PLL's high resolution allows the usage of multiple channels in any of the bands. The receiver baseband bandwidth (BW) is programmable to accommodate various deviation, data rate and crystal tolerance requirements. The transceiver employs the Zero-IF approach with I/Q demodulation. Consequently, no external components (except crystal and decoupling) are needed in most applications.

The Si4421 dramatically reduces the load on the microcontroller with the integrated digital data processing features: data filtering, clock recovery, data pattern recognition, integrated FIFO and TX data register. The automatic frequency control (AFC) feature allows the use of a low accuracy (low cost) crystal. To minimize the system cost, the Si4421 can provide a clock signal for the microcontroller, avoiding the need for two crystals.

For low power applications, the Si4421 supports low duty cycle operation based on the internal wake-up timer.

## FUNCTIONAL BLOCK DIAGRAM

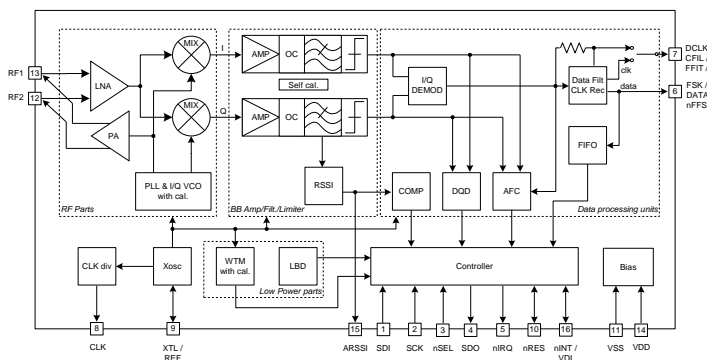

## Si4421

### PIN ASSIGNMENT



**This document refers to Si4421-IC rev A1.**

See [www.silabs.com/integration](http://www.silabs.com/integration) for any applicable errata.  
See back page for ordering information.

## FEATURES

- Fully integrated (low BOM, easy design-in)
- No alignment required in production
- Fast-settling, programmable, high-resolution PLL synthesizer
- Fast frequency-hopping capability
- High bit rate (up to 115.2 kbps in digital mode and 256 kbps in analog mode)
- Direct differential antenna input/output
- Integrated power amplifier
- Programmable TX frequency deviation (15 to 240 kHz)
- Programmable RX baseband bandwidth (67 to 400 kHz)
- Analog and digital RSSI outputs
- Automatic frequency control (AFC)
- Data quality detection (DQD)
- Internal data filtering and clock recovery
- RX synchron pattern recognition
- SPI compatible serial control interface
- Clock and reset signals for microcontroller
- 16-bit RX Data FIFO
- Two 8-bit TX data registers
- Low power duty cycle mode
- Standard 10 MHz crystal reference with on-chip tuning
- Wake-up timer
- 2.2 to 3.8 V supply voltage
- Low power consumption
- Low standby current (0.3 μA)
- Compact 16 pin TSSOP package
- Supports very short packets (down to 3 bytes)
- Excellent temperature stability of the RF parameters
- Good adjacent channel rejection/blocking

## TYPICAL APPLICATIONS

- Home security and alarm
- Remote control, keyless entry
- Wireless keyboard/mouse and other PC peripherals
- Toy controls
- Remote keyless entry
- Tire pressure monitoring
- Telemetry
- Personal/patient data logging
- Remote automatic meter reading



## DETAILED FEATURE-LEVEL DESCRIPTION

The Si4421 FSK transceiver is designed to cover the unlicensed frequency bands at 433, 868 and 915 MHz. The device facilitates compliance with FCC and ETSI requirements.

The receiver block employs the Zero-IF approach with I/Q demodulation, allowing the use of a minimal number of external components in a typical application. The Si4421 incorporates a fully integrated multi-band PLL synthesizer, PA with antenna tuning, an LNA with switchable gain, I/Q down converter mixers, baseband filters and amplifiers, and an I/Q demodulator followed by a data filter.

### PLL

The programmable PLL synthesizer determines the operating frequency, while preserving accuracy based on the on-chip crystal-controlled reference oscillator. The PLL's high resolution allows the usage of multiple channels in any of the bands.

### RF Power Amplifier (PA)

The power amplifier has an open-collector differential output and can directly drive different PCB antennas with a programmable output power level. An automatic antenna tuning circuit is built in to avoid costly trimming procedures and the so-called "hand effect".

### LNA

The LNA has approximately 250 Ohm input impedance, which functions well with the proposed antennas (see: Application Notes available from [www.silabs.com/integration](http://www.silabs.com/integration))

If the RF input of the chip is connected to 50 Ohm devices, an external matching circuit is required to provide the correct matching and to minimize the noise figure of the receiver.

The LNA gain can be selected in four steps (between 0 and -20dB relative to the highest gain) according to RF signal strength. It can be useful in an environment with strong interferers.

### Baseband Filters

The receiver bandwidth is selectable by programming the bandwidth (BW) of the baseband filters. This allows setting up the receiver according to the characteristics of the signal to be received.

An appropriate bandwidth can be chosen to accommodate various FSK deviation, data rate and crystal tolerance requirements. The filter structure is 7<sup>th</sup> order Butterworth low-pass with 40 dB suppression at  $2 \cdot BW$  frequency. Offset cancellation is done by using a high-pass filter with a cut-off frequency below 7 kHz.

**Full Baseband Amplifier Transfer Function  
BW=67kHz**

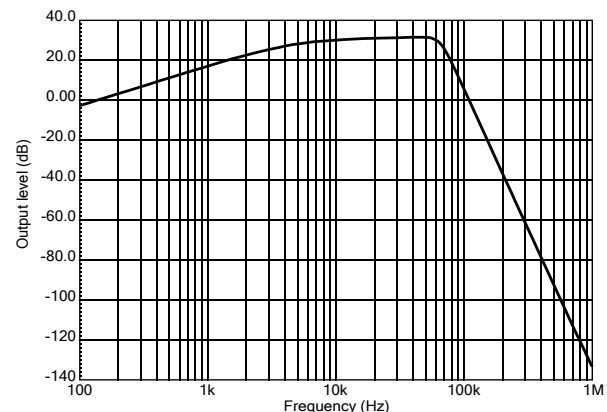

### Data Filtering and Clock Recovery

Output data filtering can be completed by an external capacitor or by using digital filtering according to the final application.

**Analog operation:** The filter is an RC type low-pass filter followed by a Schmitt-trigger (St). The resistor (10 kOhm) and the St are integrated on the chip. An (external) capacitor can be chosen according to the actual bit rate. In this mode, the receiver can handle up to 256 kbps data rate. The FIFO cannot be used in this mode and clock is not provided for the demodulated data.

**Digital operation:** A digital filter is used with a clock frequency at 29 times the bit rate. In this mode, there is a clock recovery circuit (CR), which can provide synchronized clock to the data. Using this clock the received data can fill a FIFO. The CR has three operation modes: fast, slow, and automatic. In slow mode, its noise immunity is very high, but it has slower settling time and requires more accurate data timing than in fast mode. In automatic mode, the CR automatically changes between fast and slow mode. The CR starts in fast mode, then after locking, it automatically switches to slow mode

(Only the digital data filter and the clock recovery use the bit rate clock. For analog operation, there is no need for setting the correct bit rate.)

## Data Validity Blocks

### RSSI

A digital RSSI output is provided to monitor the input signal level. It goes high if the received signal strength exceeds a given preprogrammed level. An analog RSSI signal is also available. The RSSI settling time depends on the external filter capacitor. Pin 15 is used as analog RSSI output. The digital RSSI can be monitored by reading the status register.

**Typical Analog ARSSI Voltage vs. RF Input Power**

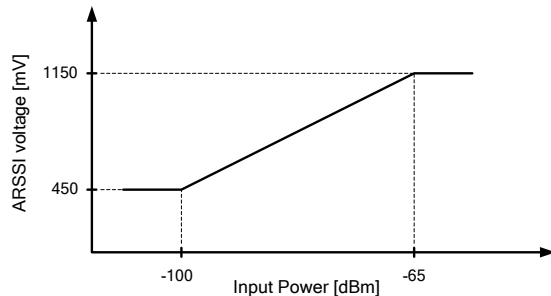

### DQD

The operation of the Data Quality Detector is based on counting the spikes on the unfiltered received data. High output signal indicates an operating FSK transmitter within baseband filter bandwidth from the local oscillator. DQD threshold parameter can be set by using the *Data Filter Command* (page 20).

### AFC

By using an integrated Automatic Frequency Control (AFC) feature, the receiver can minimize the TX/RX offset in discrete steps, allowing the use of:

- Narrower receiver bandwidth (i.e. increased sensitivity)
- Higher data rate
- Inexpensive crystals

### Crystal Oscillator

The Si4421 has a single-pin crystal oscillator circuit, which provides a 10 MHz reference signal for the PLL. To reduce external parts and simplify design, the crystal load capacitor is internal and programmable. Guidelines for selecting the appropriate crystal can be found later in this datasheet.

The transceiver can supply a clock signal for the microcontroller; so accurate timing is possible without the need for a second crystal.

When the microcontroller turns the crystal oscillator off by clearing the appropriate bit using the *Power Management Command* (page 16), the chip provides a fixed number (192) of further clock pulses ("clock tail") for the microcontroller to let it go to idle or sleep mode. If this clock output is not used, it is

suggested to turn the output buffer off by the *Power Management Command* (page 16).

### Low Battery Voltage Detector

The low battery detector circuit monitors the supply voltage and generates an interrupt if it falls below a programmable threshold level. The detector circuit has 50 mV hysteresis.

### Wake-Up Timer

The wake-up timer has very low current consumption (1.5  $\mu$ A typical) and can be programmed from 1 ms to several days with an accuracy of  $\pm 10\%$ .

The wake-up timer calibrates itself to the crystal oscillator at every startup. For proper calibration of the wake-up timer the crystal oscillator must be running before the wake-up timer is enabled. The calibration process takes approximately 0.5ms. For the crystal start up time (tsx), see page 12.

### Event Handling

In order to minimize current consumption, the transceiver supports different power saving modes. Active mode can be initiated by several wake-up events (negative logical pulse on nINT input, wake-up timer timeout, low supply voltage detection, on-chip FIFO filled up or receiving a request through the serial interface).

If any wake-up event occurs, the wake-up logic generates an interrupt signal, which can be used to wake up the microcontroller, effectively reducing the period the microcontroller has to be active. The source of the interrupt can be read out from the transceiver by the microcontroller through the SDO pin.

### Interface and Controller

An SPI compatible serial interface lets the user select the frequency band, center frequency of the synthesizer, and the bandwidth of the baseband signal path. Division ratio for the microcontroller clock, wake-up timer period, and low supply voltage detector threshold are also programmable. Any of these auxiliary functions can be disabled when not needed. All parameters are set to default after power-on; the programmed values are retained during sleep mode. The interface supports the read-out of a status register, providing detailed information about the status of the transceiver and the received data.

The transmitter block is equipped with two 8-bit wide TX data registers. It is possible to write 8 bits into the register in burst mode and the internal bit rate generator transmits the bits out with the predefined rate. For further details, see the *TX Register Buffered Data Transmission* section (page 29).

It is also possible to store the received data bits into a FIFO register and read them out in a buffered mode.

## PACKAGE PIN DEFINITIONS

Pin type key: D=digital, A=analog, S=supply, I=input, O=output, IO=input/output



Pin	Name	Type	Function
1	SDI	DI	Data input of the serial control interface
2	SCK	DI	Clock input of the serial control interface
3	nSEL	DI	Chip select input of the serial control interface (active low)
4	SDO	DO	Serial data output with bus hold
5	nIRQ	DO	Interrupt request output (active low)
6	FSK	DI	Transmit FSK data input (internal pull up resistor 133 k)
	DATA	DO	Received data output (FIFO not used)
	nFFS	DI	FIFO select input (active low). In FIFO mode, when bit <i>ef</i> is set in <i>Configuration Setting Command</i> , page 16 (internal pull up resistor 133 k)
7	DLCK	DO	Received data clock output (Digital filter used, FIFO not used)
	CFIL	AIO	External data filter capacitor connection (Analog filter used)
	FFIT	DO	FIFO interrupt (active high). In FIFO mode, when bit <i>ef</i> is set in <i>Configuration Setting Command</i>
8	CLK	DO	Microcontroller clock output
9	XTL	AIO	Crystal connection (the other terminal of crystal to VSS) or external reference input
	REF	AIO	External reference input. Use 33 pF series coupling capacitor
10	nRES	DIO	Open drain reset output with internal pull-up and input buffer (active low)
11	VSS	S	Ground reference voltage
12	RF2	AIO	RF differential signal input/output
13	RF1	AIO	RF differential signal input/output
14	VDD	S	Positive supply voltage
15	ARSSI	AO	Analog RSSI output
16	nINT	DI	Interrupt input (active low)
	VDI	DO	Valid data indicator output

**Note:** The actual mode of the multipurpose pins (pin 6 and 7) is determined by the TX/RX data I/O settings of the transceiver.

## Internal Pin Connections

Pin	Name	Internal connection
1	SDI	
2	SCK	
3	nSEL	
4	SDO	
5	nIRQ	
6	FSK	
	DATA	
	nFFS	
7	DLCK	
	CFIL	
	FFIT	
8	CLK	
	REF	
9	XTL	
	REF	

Pin	Name	Internal connection
10	nRES	
11	VSS	
12	RF2	
13	RF1	
14	VDD	
15	ARSSI	
16	nINT	
	VDI	

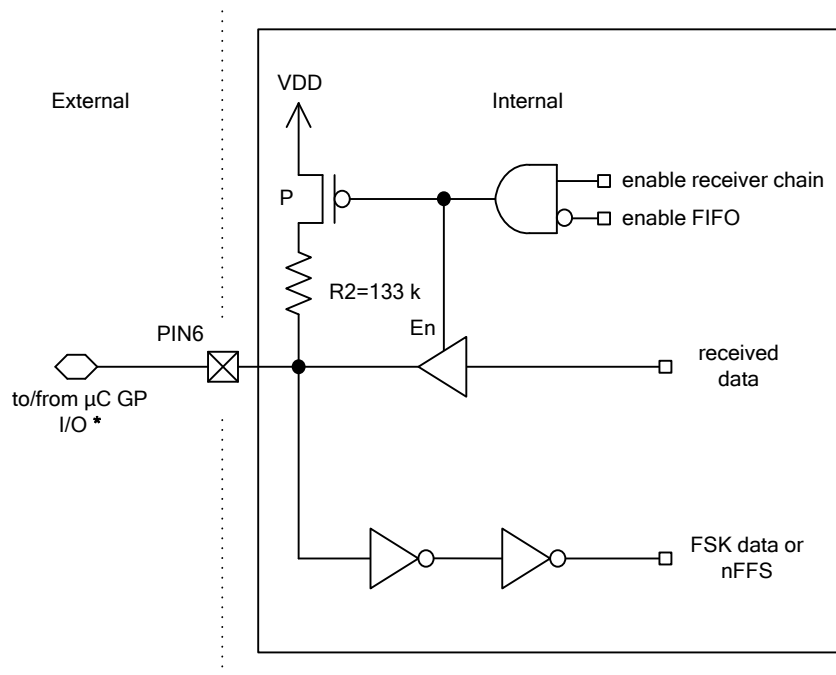
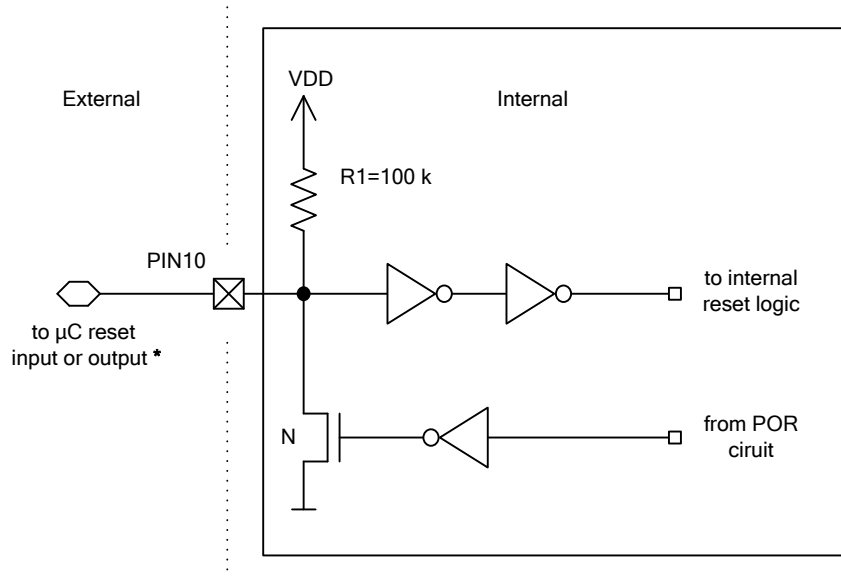
**PIN6 Logic Diagram (FSK / DATA / nFFS)****PIN10 Logic Diagram (nRES I/O)**

\* **Note:** These pins can be left floating.

## Typical Application

### Typical application with FIFO usage



### Recommended supply decoupling capacitor values

C2 and C3 should be 0603 size ceramic capacitors to achieve the best supply decoupling.

Band [MHz]	C1	C2	C3
433	2.2 $\mu$ F	10nF	220pF
868	2.2 $\mu$ F	10nF	47pF
915	2.2 $\mu$ F	10nF	33pF

Property	C1	C2	C3
SMD size	A	0603	0603
Dielectric	Tantalum	Ceramic	Ceramic

### Pin Function vs. Operation Mode

Mode	Bit setting	Function	Pin 6	Pin 7
Transmit	$el = 0$	Internal TX data register disabled	TX data input	Not used
	$el = 1$	Internal TX data register enabled	nFFS input (TX data register can be accessed)	
Receive	$ef = 0$	Receiver FIFO disabled	RX data output	RX data clock output
	$ef = 1$	Receiver FIFO disabled	nFFS input (RX data FIFO can be accessed)	FFIT output

The  $el$  and  $ef$  bits can be found in the *Configuration Setting Command* on page 16. Bit  $el$  enables the internal TX data register. Bit  $ef$  enables the FIFO mode.



## GENERAL DEVICE SPECIFICATIONS

All voltages are referenced to  $V_{ss}$ , the potential on the ground reference pin VSS.

### Absolute Maximum Ratings (non-operating)

Symbol	Parameter	Min	Max	Units
$V_{dd}$	Positive supply voltage	-0.5	6	V
$V_{in}$	Voltage on any pin (except RF1 and RF2)	-0.5	$V_{dd}+0.5$	V
$V_{oc}$	Voltage on open collector outputs (RF1, RF2)	-0.5	$V_{dd}+1.5$ (Note 1)	V
$I_{in}$	Input current into any pin except VDD and VSS	-25	25	mA
ESD	Electrostatic discharge with human body model		1000	V
$T_{st}$	Storage temperature	-55	125	°C
$T_{ld}$	Lead temperature (soldering, max 10 s)		260	°C

### Recommended Operating Range

Symbol	Parameter	Min	Max	Units
$V_{dd}$	Positive supply voltage	2.2	3.8	V
$V_{oc}$	Voltage range on open collector outputs (RF1, RF2)	$V_{dd}-1.5$ (Note 2)	$V_{dd}+1.5$	V
$T_{op}$	Ambient operating temperature	-40	85	°C

**Note 1:** The voltage on RF1 and RF2 pins can be higher than the actual  $V_{dd}$  but cannot exceed 7 V.

**Note 2:** The actual voltage on RF1 and RF2 pins can be lower than the current  $V_{dd}$  but never should go below 1.2 V.

## ELECTRICAL SPECIFICATION

Test Conditions:  $T_{op} = 27\text{ }^{\circ}\text{C}$ ;  $V_{dd} = V_{oc} = 3.3\text{ V}$

### DC Characteristics

Symbol	Parameter	Conditions/Notes	Min	Typ	Max	Units
$I_{dd\_TX\_0}$	Supply current (TX mode, $P_{out} = 0\text{ dBm}$ )	433 MHz band		15		mA
		868 MHz band		16		
		915 MHz band		17		
$I_{dd\_TX\_PMAX}$	Supply current (TX mode, $P_{out} = P_{max}$ )	433 MHz band		22	26	mA
		868 MHz band		23	27	
		915 MHz band		24	28	
$I_{dd\_RX}$	Supply current (RX mode)	433 MHz band		11	13	mA
		868 MHz band		12	14	
		915 MHz band		13	15	
$I_{pd}$	Standby current (Sleep mode)	All blocks disabled		0.3	1	$\mu\text{A}$
$I_{lb}$	Low battery voltage detector current consumption			0.5	1.7	$\mu\text{A}$
$I_{wt}$	Wake-up timer current consumption			1.5	3.5	$\mu\text{A}$
$I_x$	Idle current	Crystal oscillator on (Note 1)		0.6	1.2	mA
$V_{lb}$	Low battery detect threshold	Programmable in 0.1 V steps	2.25		3.75	V
$V_{lba}$	Low battery detection accuracy			$\pm 3$		%
$V_{il}$	Digital input low level voltage				$0.3 \cdot V_{dd}$	V
$V_{ih}$	Digital input high level voltage		$0.7 \cdot V_{dd}$			V
$I_{il}$	Digital input current	$V_{il} = 0\text{ V}$	-1		1	$\mu\text{A}$
$I_{ih}$	Digital input current	$V_{ih} = V_{dd}$ , $V_{dd} = 3.8\text{ V}$	-1		1	$\mu\text{A}$
$V_{ol}$	Digital output low level	$I_{ol} = 2\text{ mA}$			0.4	V
$V_{oh}$	Digital output high level	$I_{oh} = -2\text{ mA}$	$V_{dd}-0.4$			V

Notes are on page 13.

**AC Characteristics (PLL parameters)**

Symbol	Parameter	Conditions/Notes	Min	Typ	Max	Units
$f_{ref}$	PLL reference frequency	(Note 2)	9	10	11	MHz
$f_o$	Receiver LO/Transmitter carrier frequency	433 MHz band, 2.5 kHz resolution	430.24		439.75	MHz
		868 MHz band, 5.0 kHz resolution	860.48		879.51	
		915 MHz band, 7.5 kHz resolution	900.72		929.27	
$t_{lock}$	PLL lock time	Frequency error < 1kHz after 10 MHz step		30		$\mu$ s
$t_{stP}$	PLL startup time (Note 10)	With a running crystal oscillator		200	300	$\mu$ s

**AC Characteristics (Receiver)**

Symbol	Parameter	Conditions/Notes	Min	Typ	Max	Units
BW	Receiver bandwidth	mode 0		67		kHz
		mode 1		134		
		mode 2		200		
		mode 3		270		
		mode 4		340		
		mode 5		400		
BR <sub>RX</sub>	FSK bit rate (Note 10)	With internal digital filters	0.6		115.2	kbps
BRA <sub>RX</sub>	FSK bit rate (Note 10)	With analog filter			256	kbps
P <sub>min</sub>	Receiver Sensitivity	BER 10 <sup>-3</sup> , BW=67 kHz, BR=1.2 kbps, 868 MHz Band (Note 3)		-110		dBm
AFC <sub>range</sub>	AFC locking range	$\delta f_{FSK}$ : FSK deviation in the received signal		0.8· $\delta f_{FSK}$		
IIP3 <sub>inh</sub>	Input IP3	In band interferers in high bands (868 MHz, 915 MHz)		-21		dBm
IIP3 <sub>outh</sub>	Input IP3	Out of band interferers  f-f <sub>o</sub>   > 4 MHz		-18		dBm
IIP3 <sub>inl</sub>	IIP3 (LNA -6 dB gain)	In band interferers in low band (433 MHz)		-15		dBm
IIP3 <sub>outl</sub>	IIP3 (LNA -6 dB gain)	Out of band interferers  f-f <sub>o</sub>   > 4 MHz		-12		dBm
P <sub>max</sub>	Maximum input power	LNA: high gain	0			dBm
C <sub>in</sub>	RF input capacitance			1		pF
RS <sub>a</sub>	RSSI accuracy			± 6		dB
RS <sub>r</sub>	RSSI range			46		dB
RS <sub>ps</sub>	RSSI power supply dependency	When input signal level lower than -54 dBm and greater than -100 dBm		+35		mV/V
C <sub>ARSSI</sub>	Filter capacitor for ARSSI		1			nF
RS <sub>step</sub>	RSSI programmable level steps			6		dB
RS <sub>resp</sub>	DRSSI response time	Until the RSSI signal goes high after the input signal exceeds the preprogrammed limit C <sub>ARSSI</sub> = 4.7 nF		500		$\mu$ s
P <sub>sp_rx</sub>	Receiver spurious emission				-60	dBm

Notes are on page 13.

**AC Characteristics (Transmitter)**

Symbol	Parameter	Conditions/Notes	Min	Typ	Max	Units
I <sub>OUT</sub>	Open collector output DC current	Programmable	0.5		6	mA
P <sub>max_50</sub>	Max. output power delivered to 50 Ohm load over a suitable matching network (Note 4)	In 433 MHz band		7		dBm
		In 868 MHz / 915 MHz bands		5		
P <sub>max_ant</sub>	Max. EIRP with suitable selected PCB antenna (Note 6)	In 433 MHz band with monopole antenna with matching network (Note 4)		7		dBm
		In 868 MHz / 915 MHz bands (Note 5)		7		
P <sub>out</sub>	Typical output power	Selectable in 2.5 dB steps (Note 7)	P <sub>max</sub> -17.5		P <sub>max</sub>	dBm
P <sub>sp</sub>	Spurious emission  f-f <sub>sp</sub>   > 1 MHz	At max power 50 Ohm load (Note 4)			-55	dBc
		With PCB antenna (Note 5)			-60	
P <sub>ham</sub>	Harmonic suppression	At max power 50 Ohm load (Note 4)			-35	dBc
		With PCB antenna (Note 5)			-42	
C <sub>o</sub>	Output capacitance (set by the automatic antenna tuning circuit)	In 433 MHz band	2	2.6	3.2	pF
		In 868 MHz / 915 MHz bands	2.1	2.7	3.3	
Q <sub>o</sub>	Quality factor of the output capacitance	In 433 MHz band	13	15	17	
		In 868 MHz / 915 MHz bands	8	10	12	
L <sub>out</sub>	Output phase noise	100 kHz from carrier, in 868 MHz band		-80		dBc/Hz
		1 MHz from carrier, in 868 MHz band		-103		
BR <sub>TX</sub>	FSK bit rate	Via internal TX data register			172	kbps
BRA <sub>TX</sub>	FSK bit rate	TX data connected to the FSK input			256	kbps
df <sub>fsk</sub>	FSK frequency deviation	Programmable in 15 kHz steps	15		240	kHz

**AC Characteristics (Turn-on/Turnaround timings)**

Symbol	Parameter	Conditions/Notes	Min	Typ	Max	Units
t <sub>sx</sub>	Crystal oscillator startup time	Default capacitance bank setting, crystal ESR < 50 Ohm (Note 9). Crystal load capacitance = 16 pF.		2	7	ms
T <sub>tx_XTAL_ON</sub>	Transmitter turn-on time	Synthesizer off, crystal oscillator on with 10 MHz step		250		μs
T <sub>rx_XTAL_ON</sub>	Receiver turn-on time	Synthesizer off, crystal oscillator on with 10 MHz step		250		μs
T <sub>tx_rx_SYNT_ON</sub>	Transmitter – Receiver turnover time	Synthesizer and crystal oscillator on during TX/RX change with 10 MHz step		150		μs
T <sub>rx_tx_SYNT_ON</sub>	Receiver – Transmitter turnover time	Synthesizer and crystal oscillator on during RX/TX change with 10 MHz step		150		μs

**AC Characteristics (Others)**

Symbol	Parameter	Conditions/Notes	Min	Typ	Max	Units
C <sub>xl</sub>	Crystal load capacitance, see crystal selection guide	Programmable in 0.5 pF steps, tolerance ± 10%	8.5		16	pF
t <sub>POR</sub>	Internal POR timeout	After V <sub>dd</sub> has reached 90% of final value (Note 8)			100	ms
t <sub>Pbt</sub>	Wake-up timer clock accuracy	Crystal oscillator must be enabled to ensure proper calibration at the start up. (Note 9)		± 10		%
C <sub>IND</sub>	Digital input capacitance				2	pF
t <sub>r</sub> , t <sub>f</sub>	Digital output rise/fall time	15 pF pure capacitive load			10	ns

Notes are on page 13.

**Note 1:** Measured with disabled clock output buffer

**Note 2:** Not using a 10 MHz crystal is allowed but not recommended because all crystal referred timing and frequency parameters will change accordingly

**Note 3:** See the BER diagrams in the measurement results section (page 38) for detailed information

**Note 4:** See reference design with *50 Ohm Matching Network* (page 40) for details

**Note 5:** See reference design with *Resonant PCB Antenna (BIFA)* on page 42 for details

**Note 6:** Optimal antenna admittance/impedance:

Si4421	$Y_{\text{antenna}}$ [mS]	$Z_{\text{antenna}}$ [Ohm]	$L_{\text{antenna}}$ [nH]
433 MHz	$2 - j5.9$	$52 + j152$	62
868 MHz	$1.2 - j11.9$	$7.8 + j83$	15.4
915 MHz	$1.49 - j12.8$	$9 + j77$	13.6

**Note 7:** Adjustable in 8 steps

**Note 8:** During the Power-On Reset period, commands are not accepted by the chip. In case of software reset (see *Wake-Up Timer Command*, page 26) the reset timeout is 0.25ms typical.

**Note 9:** The crystal oscillator start up time strongly depends on the capacitance seen by the oscillator. Low capacitance and low ESR crystal is recommended with low parasitic PCB layout design.

**Note 10:** By design

## CONTROL INTERFACE

Commands to the transmitter are sent serially. Data bits on pin SDI are shifted into the device upon the rising edge of the clock on pin SCK whenever the chip select pin nSEL is low. When the nSEL signal is high, it initializes the serial interface. All commands consist of a command code, followed by a varying number of parameter or data bits. All data are sent MSB first (e.g. bit 15 for a 16-bit command). Bits having no influence (don't care) are indicated with X. Special care must be taken when the microcontroller's built-in hardware serial port is used. If the port cannot be switched to 16-bit mode then a separate I/O line should be used to control the nSEL pin to ensure the low level during the whole duration of the command or a software serial control interface should be implemented. The Power-On Reset (POR) circuit sets default values in all control and command registers.

The receiver will generate an interrupt request (IT) for the microcontroller - by pulling the nIRQ pin low - on the following events:

- The TX register is ready to receive the next byte (RGIT)
- The RX FIFO has received the preprogrammed amount of bits (FFIT)
- Power-on reset (POR)
- RX FIFO overflow (FFOV) / TX register underrun (RGUR)
- Wake-up timer timeout (WKUP)
- Negative pulse on the interrupt input pin nINT (EXT)
- Supply voltage below the preprogrammed value is detected (LBD)

FFIT and FFOV are applicable when the RX FIFO is enabled. RGIT and RGUR are applicable only when the TX register is enabled. To identify the source of the IT, the status bits should be read out.

### Timing Specification

Symbol	Parameter	Minimum value [ns]
$t_{CH}$	Clock high time	25
$t_{CL}$	Clock low time	25
$t_{SS}$	Select setup time (nSEL falling edge to SCK rising edge)	10
$t_{SH}$	Select hold time (SCK falling edge to nSEL rising edge)	10
$t_{SHI}$	Select high time	25
$t_{DS}$	Data setup time (SDI transition to SCK rising edge)	5
$t_{DH}$	Data hold time (SCK rising edge to SDI transition)	5
$t_{OD}$	Data delay time	10

### Timing Diagram



## Control Commands

	Control Command	Related Parameters/Functions	Related control bits
1	Configuration Setting Command	Frequency band, crystal oscillator load capacitance, RX FIFO and TX register enable	<i>el, ef, b1 to b0, x3 to x0</i>
2	Power Management Command	Receiver/Transmitter mode change, synthesizer, crystal oscillator, PA, wake-up timer, clock output enable	<i>er, ebb, et, es, ex, eb, ew, dc</i>
3	Frequency Setting Command	Frequency of the local oscillator/carrier signal	<i>f11 to f0</i>
4	Data Rate Command	Bit rate	<i>cs, r6 to r0</i>
5	Receiver Control Command	Function of pin 16, Valid Data Indicator, baseband bandwidth, LNA gain, digital RSSI threshold	<i>p16, d1 to d0, i2 to i0, g1 to g0, r2 to r0</i>
6	Data Filter Command	Data filter type, clock recovery parameters	<i>al, ml, s, f2 to f0</i>
7	FIFO and Reset Mode Command	Data FIFO IT level, FIFO start control, FIFO enable and FIFO fill enable, POR sensitivity	<i>f3 to f0, sp, ff, al, dr</i>
8	Synchron Pattern Command	Synchron pattern	<i>b7 to b0</i>
9	Receiver FIFO Read Command	RX FIFO read	
10	AFC Command	AFC parameters	<i>a1 to a0, r11 to r10, st, fi, oe, en</i>
11	TX Configuration Control Command	Modulation parameters, output power	<i>mp, m3 to m0, p2 to p0</i>
12	PLL Setting Command	CLK out buffer speed, dithering, PLL bandwidth	<i>ob1 to ob0, ddit, dly, bw0</i>
13	Transmitter Register Write Command	TX data register write	<i>t7 to t0</i>
14	Wake-Up Timer Command	Wake-up time period	<i>r4 to r0, m7 to m0</i>
15	Low Duty-Cycle Command	Enable and set low duty-cycle mode	<i>d6 to d0, en</i>
16	Low Battery Detector and Microcontroller Clock Divider Command	LBD voltage and microcontroller clock division ratio	<i>d2 to d0, v3 to v0</i>
17	Status Read Command	Status bit readout	

In general, setting the given bit to one will activate the related function. In the following tables, the POR column shows the default values of the command registers after power-on.

## Control Register Default Values

	Control Register	Power-On Reset Value
1	Configuration Setting Command	8008h
2	Power Management Command	8208h
3	Frequency Setting Command	A680h
4	Data Rate Command	C623h
5	Receiver Control Command	9080h
6	Data Filter Command	C22Ch
7	FIFO and Reset Mode Command	CA80h
8	Synchron Pattern Command	CED4h
9	Receiver FIFO Read Command	B000h
10	AFC Command	C4F7h
11	TX Configuration Control Command	9800h
12	PLL Setting Command	CC77h
13	Transmitter Register Write Command	B8AAh
14	Wake-Up Timer Command	E196h
15	Low Duty-Cycle Command	C80Eh
16	Low Battery Detector and Microcontroller Clock Divider Command	C000h
17	Status Read Command	0000h

## Description of the Control Commands

### 1. Configuration Setting Command

Bit	15	14	13	12	11	10	9	8	7	6	5	4	3	2	1	0	POR
	1	0	0	0	0	0	0	0	el	ef	b1	b0	x3	x2	x1	x0	8008h

Bit *el* enables the internal data register.

Bit *ef* enables the FIFO mode. If *ef* = 0 then DATA (pin 6) and DCLK (pin 7) are used for data and data clock output.

<i>b1</i>	<i>b0</i>	Frequency Band
0	0	Reserved
0	1	433
1	0	868
1	1	915

<i>x3</i>	<i>x2</i>	<i>x1</i>	<i>x0</i>	Crystal Load Capacitance [pF]
0	0	0	0	8.5
0	0	0	1	9.0
0	0	1	0	9.5
0	0	1	1	10.0
...				
1	1	1	0	15.5
1	1	1	1	16.0

### 2. Power Management Command

Bit	15	14	13	12	11	10	9	8	7	6	5	4	3	2	1	0	POR
	1	0	0	0	0	0	1	0	er	ebb	et	es	ex	eb	ew	dc	8208h

Bit	Function of the control bit	Related blocks
<i>er</i>	Enables the whole receiver chain	RF front end, baseband, synthesizer, crystal oscillator
<i>ebb</i>	The receiver baseband circuit can be separately switched on	Baseband
<i>et</i>	Switches on the PLL, the power amplifier, and starts the transmission (If TX register is enabled)	Power amplifier, synthesizer, crystal oscillator
<i>es</i>	Turns on the synthesizer	Synthesizer
<i>ex</i>	Turns on the crystal oscillator	Crystal oscillator
<i>eb</i>	Enables the low battery detector	Low battery detector
<i>ew</i>	Enables the wake-up timer	Wake-up timer
<i>dc</i>	Disables the clock output (pin 8)	Clock output buffer

The *ebb*, *es*, and *ex* bits are provided to optimize the TX to RX or RX to TX turnaround time.

The RF frontend consist of the LNA (low noise amplifier) and the mixer. The synthesizer block has two main components: the VCO and the PLL. The baseband section contains the baseband amplifier, low pass filter, limiter and the I/Q demodulator.

To decrease TX/RX turnaround time, it is possible to leave the baseband section powered on. Switching to RX mode means disabling the PA and enabling the RF frontend. Since the baseband block is already on, the internal startup calibration will not be performed, the turnaround time will be shorter.

The synthesizer also has an internal startup calibration procedure. If quick RX/TX switching needed it may worth to leave this block on. Enabling the transmitter using the *et* bit will turn on the PA, the synthesizer is already up and running. The power amplifier almost immediately produces TX signal at the output.

The crystal oscillator provides reference signal to the RF synthesizer, the baseband circuits and the digital signal processor part. When the receiver or the transmitter part frequently used, it is advised to leave the oscillator running because the crystal might need a few milliseconds to start. This time mainly depends on the crystal parameters.

It is important to note that leaving blocks unnecessary turned on can increase the current consumption thus decreasing the battery life.



Logic connections between power control bits:

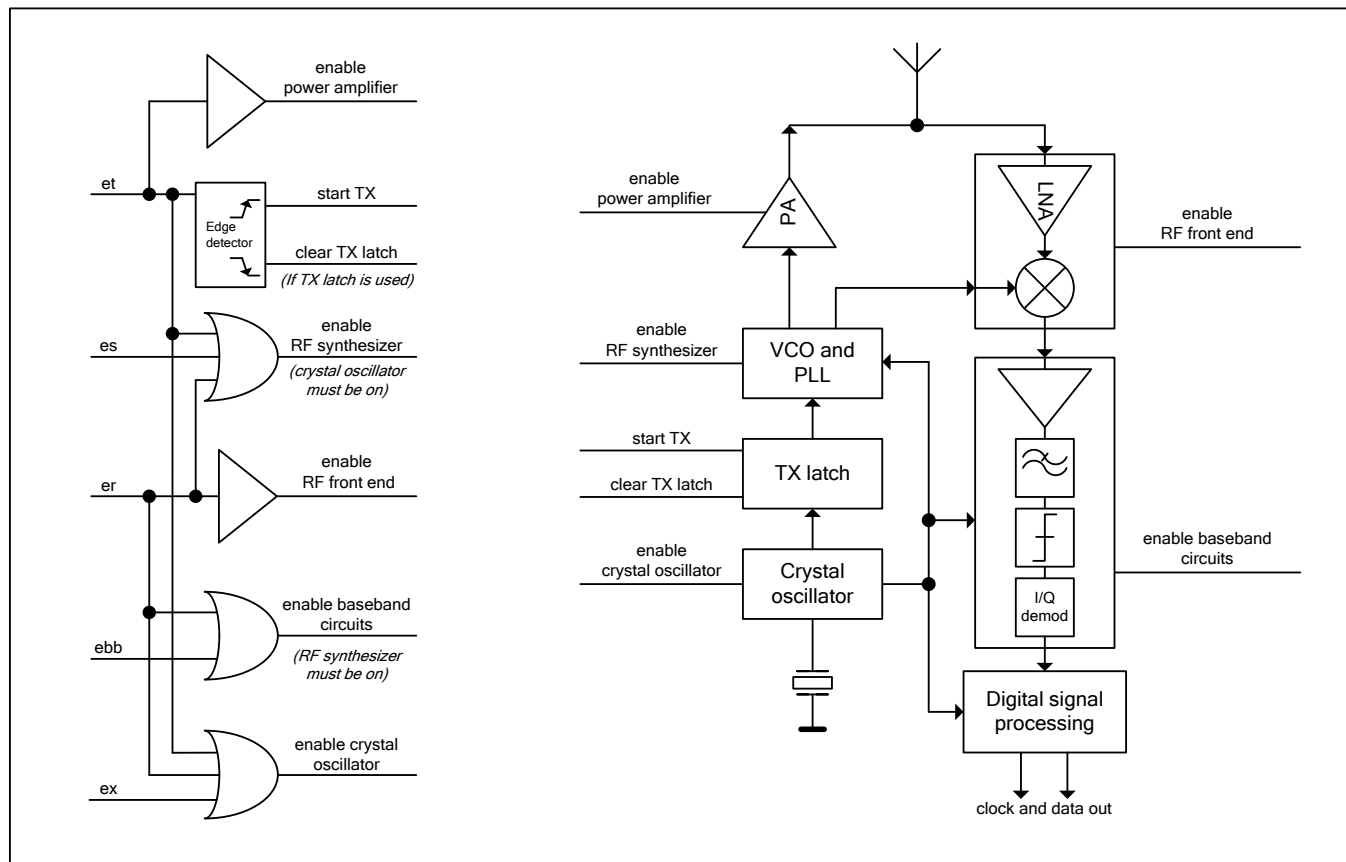

**Note:**

- If both *et* and *er* bits are set the chip goes to receive mode.
- FSK / nFFS input are equipped with internal pull-up resistor. To achieve minimum current consumption do not pull this input to logic low in sleep mode.
- To enable the RF synthesizer, the crystal oscillator must be turned on
- To turn on the baseband circuits, the RF synthesizer (and this way the crystal oscillator) must be enabled.
- Setting the *er* bit automatically turns on the crystal oscillator, the synthesizer, the baseband circuits and the RF fronted.
- Setting the *et* bit automatically turns on the crystal oscillator, the synthesizer and the RF power amplifier.

**Clock tail feature:** When the clock output (pin 8) used to provide clock signal for the microcontroller (*dc* bit is set to 0), it is possible to use the clock tail feature. This means that the crystal oscillator turn off is delayed, after issuing the command (clearing the *ex* bit) 192 more clock pulses are provided. This ensures that the microcontroller can switch itself to low power consumption mode. In order to use this feature, a *Status Read Command* (page 28) must be issued before the *ex* bit set to zero. If status read was not performed then the clock output shuts down immediately leaving the microcontroller in unknown state.

**Automatic crystal oscillator enable/disable feature:** When an interrupt occurs, the crystal oscillator automatically turns on – regardless to the setting of the *ex* bit – to supply clock signal to the microcontroller. After clearing all interrupts by handling them properly (see the *Interrupt Handling* section, page 29) and performing *Status Read Command*, the crystal oscillator is automatically turned off. The clock tail feature provides enough clock pulses for the microcontroller to go to low power mode. Due to this automatic feature, it is not possible to turn off the crystal by clearing the *ex* bit if any interrupt is active. For example, after power on the POR interrupt must be cleared by a status read then writing zero to the *ex* bit will put the part into sleep mode. Very important to clear all interrupts before turning the *ex* bit off because the extra current required by running crystal oscillator can shorten the battery life significantly.

Disabling the clock output (bit *dc*=1) turns off both the clock tail and the automatic crystal oscillator enable/disable feature, only the *ex* bit controls the crystal oscillator (supposing that both the *er* and *et* bits are cleared), the interrupts have no effect on it.

### 3. Frequency Setting Command

Bit	15	14	13	12	11	10	9	8	7	6	5	4	3	2	1	0	POR
	1	0	1	0	f11	f10	f9	f8	f7	f6	f5	f4	f3	f2	f1	f0	A680h

The 12-bit parameter F (bits *f11* to *f0*) should be in the range of 96 and 3903. When F value sent is out of range, the previous value is kept. The synthesizer center frequency  $f_0$  can be calculated as:

$$f_0 = 10 \cdot C1 \cdot (C2 + F/4000) \text{ [MHz]}$$

The constants C1 and C2 are determined by the selected band as:

Band [MHz]	C1	C2
433	1	43
868	2	43
915	3	30

Band	Minimum Frequency	Maximum Frequency	PLL Frequency Step
433 MHz	430.2400 MHz	439.7575 MHz	2.5 kHz
868 MHz	860.4800 MHz	879.5150 MHz	5.0 kHz
915 MHz	900.7200 MHz	929.2725 MHz	7.5 kHz

### 4. Data Rate Command

Bit	15	14	13	12	11	10	9	8	7	6	5	4	3	2	1	0	POR
	1	1	0	0	0	1	1	0	cs	r6	r5	r4	r3	r2	r1	r0	C623h

The actual bit rate in transmit mode and the expected bit rate of the received data stream in receive mode is determined by the 7-bit parameter R (bits *r6* to *r0*) and bit *cs*.

$$BR = 10000 / 29 / (R+1) / (1+cs \cdot 7) \text{ [kbps]}$$

In the receiver set R according to the next function:

$$R = (10000 / 29 / (1+cs \cdot 7) / BR) - 1, \text{ where BR is the expected bit rate in kbps.}$$

Apart from setting custom values, the standard bit rates from 600 bps to 115.2 kbps can be approximated with small error.

Data rate accuracy requirements:

$$\text{Clock recovery in slow mode: } \Delta BR/BR < 1/(29 \cdot N_{bit})$$

$$\text{Clock recovery in fast mode: } \Delta BR/BR < 3/(29 \cdot N_{bit})$$

BR is the bit rate set in the receiver and  $\Delta BR$  is the bit rate difference between the transmitter and the receiver.  $N_{bit}$  is the maximum number of consecutive ones or zeros in the data stream. It is recommended for long data packets to include enough 1/0 and 0/1 transitions, and to be careful to use the same division ratio in the receiver and in the transmitter.

### 5. Receiver Control Command

Bit	15	14	13	12	11	10	9	8	7	6	5	4	3	2	1	0	POR
	1	0	0	1	0	p16	d1	d0	i2	i1	i0	g1	g0	r2	r1	r0	9080h

Bit 10 (*p16*): Pin 16 function select

<i>p16</i>	Function of pin 16
0	Interrupt input
1	VDI output

Bits 9-8 (*d1* to *d0*): VDI (valid data indicator) signal response time setting:

<i>d1</i>	<i>d0</i>	Response
0	0	Fast
0	1	Medium
1	0	Slow
1	1	Always on

VDI Logic Diagram:



Slow mode: The VDI signal will go high only if the DRSSI, DQD and the CR\_LOCK (Clock Recovery Locked) signals present at the same time. It stays high until any of the abovementioned signals present; it will go low when all the three input signals are low.

Medium mode: The VDI signal will be active when the CR\_LOCK signal and either the DRSSI or the DQD signal is high. The valid data indicator will go low when either the CR\_LOCK gets inactive or both of the DRSSI or DQD signals go low.

Fast mode: The VDI signal follows the level of the DQD signal.

Always mode: VDI is connected to logic high permanently. It stays always high independently of the receiving parameters.

Bits 7-5 (*i2* to *i0*): Receiver baseband bandwidth (BW) select:

<i>i2</i>	<i>i1</i>	<i>i0</i>	BW [kHz]
0	0	0	Reserved
0	0	1	400
0	1	0	340
0	1	1	270
1	0	0	200
1	0	1	134
1	1	0	67
1	1	1	Reserved

**Note:** For the optimal bandwidth settings at different data rates see the table on page 38.

Bits 4-3 (*g1* to *g0*): LNA gain select:

<i>g1</i>	<i>g0</i>	Gain relative to maximum [dB]
0	0	0
0	1	-6
1	0	-14
1	1	-20

Bits 2-0 (*r2* to *r0*): RSSI detector threshold:

<i>r2</i>	<i>r1</i>	<i>r0</i>	RSSI <sub>setth</sub> [dBm]
0	0	0	-103
0	0	1	-97
0	1	0	-91
0	1	1	-85
1	0	0	-79
1	0	1	-73
1	1	0	Reserved
1	1	1	Reserved

The RSSI threshold depends on the LNA gain, the real RSSI threshold can be calculated:

$$\text{RSSI}_{\text{th}} = \text{RSSI}_{\text{setth}} + G_{\text{LNA}}$$

## 6. Data Filter Command

Bit	15	14	13	12	11	10	9	8	7	6	5	4	3	2	1	0	
	1	1	0	0	0	0	1	0	al	ml	1	s	1	f2	f1	f0	POR
																	C22Ch

Bit 7 (*al*): Clock recovery (CR) auto lock control

- 1: auto mode: the CR starts in fast mode, after locking it switches to slow mode. Bit 6 (*ml*) has no effect.
- 0: manual mode, the clock recovery mode is set by Bit 6 (*ml*)

Bit 6 (*ml*): Clock recovery lock control

- 1: fast mode, fast attack and fast release (4 to 8-bit preamble (1010...) is recommended)
  - 0: slow mode, slow attack and slow release (12 to 16-bit preamble is recommended)
- Using the slow mode requires more accurate bit timing (see *Data Rate Command*, page 18).

Bit 4 (*s*): Select the type of the data filter:

<i>s</i>	Filter Type
0	Digital filter
1	Analog RC filter

Digital: This is a digital realization of an analog RC filter followed by a comparator with hysteresis. The time constant is automatically adjusted to the bit rate defined by the *Data Rate Command* (page 18).

**Note:** Bit rate cannot exceed 115 kbps in this mode.

Analog RC filter: The demodulator output is fed to pin 7 over a 10 kOhm resistor. The filter cut-off frequency is set by the external capacitor connected to this pin and VSS.

The table shows the optimal filter capacitor values for different data rates

Data Rate [kbps]	1.2	2.4	4.8	9.6	19.2	38.4	57.6	115.2	256
Filter Capacitor Value	12 nF	8.2 nF	6.8 nF	3.3 nF	1.5 nF	680 pF	270 pF	150 pF	100 pF

**Note:** If analog RC filter is selected the internal clock recovery circuit and the FIFO cannot be used.

Bits 2-0 (f2 to f0): DQD threshold parameter.

The Data Quality Detector is a digital processing part of the radio, connected to the demodulator - it is an indicator reporting the reception of an FSK modulated RF signal. It will work every time the receiver is on. Setting this parameter defines how clean incoming data stream would be stated as good data (valid FSK signal).

If the internally calculated data quality value exceeds the DQD threshold parameter for five consecutive data bits for both the high and low periods, then the DQD signal goes high.

The DQD parameter in the Data Filter Command should be chosen according to the following rules:

- The DQD parameter can be calculated with the following formula:  

$$DQD_{par} = 4 \times (\text{deviation} - TX-RX_{offset}) / \text{bit rate}$$
- It should be larger than 4 because otherwise noise might be treated as a valid FSK signal
- The maximum value is 7.

### 7. FIFO and Reset Mode Command

Bit	15	14	13	12	11	10	9	8	7	6	5	4	3	2	1	0	POR
	1	1	0	0	1	0	1	0	f3	f2	f1	f0	sp	al	ff	dr	CA80h

Bits 7-4 (f3 to f0): FIFO IT level. The FIFO generates IT when the number of received data bits reaches this level.

Bit 3 (sp): Select the length of the synchron pattern:

sp	Byte1	Byte0 (POR)	Synchron Pattern (Byte1+Byte0)
0	2Dh	D4h	2DD4h
1	Not used	D4h	D4h

**Note:** The synchron pattern consists of one or two bytes depending on the sp bit. Byte1 is fixed 2Dh, Byte0 can be programmed by the *Synchron Pattern Command* (page 22).

Bit 2 (al): Set the input of the FIFO fill start condition:

al	FIFO fill start condition
0	Synchron pattern
1	Always fill



Bit 1 (*ff*): FIFO fill will be enabled after synchron pattern reception. The FIFO fill stops when this bit is cleared.

Bit 0 (*dr*): Disables the highly sensitive RESET mode.

<i>dr</i>	Reset mode	Reset triggered when
0	Sensitive reset	$V_{dd}$ below 1.6V, $V_{dd}$ glitch greater than 600mV
1	Non-sensitive reset	$V_{dd}$ below 250mV

**Note:** To restart the synchron pattern recognition, bit 1 (*ef*, FIFO fill enable) should be cleared and set.

## 8. Synchron Pattern Command

Bit	15	14	13	12	11	10	9	8	7	6	5	4	3	2	1	0	POR
	1	1	0	0	1	1	1	0	b7	b6	b5	b4	b3	b2	b1	b0	CED4h

The Byte0 of the synchron pattern (see *FIFO and Reset Mode command*, page 21) can be reprogrammed by B <b7:b0>.

## 9. Receiver FIFO Read Command

Bit	15	14	13	12	11	10	9	8	7	6	5	4	3	2	1	0	POR
	1	0	1	1	0	0	0	0	0	0	0	0	0	0	0	0	B000h

With this command, the controller can read 8 bits from the receiver FIFO. Bit 6 (*ef*) must be set in *Configuration Setting Command* (page 16).



**Note:** During FIFO access  $f_{SCK}$  cannot be higher than  $f_{ref}/4$ , where  $f_{ref}$  is the crystal oscillator frequency. When the duty-cycle of the clock signal is not 50 % the shorter period of the clock pulse width should be at least  $2/f_{ref}$ .

## 10. AFC Command

Bit	15	14	13	12	11	10	9	8	7	6	5	4	3	2	1	0	POR
	1	1	0	0	0	1	0	0	a1	a0	r11	r10	st	fi	oe	en	C4F7h

Bit 7-6 (*a1* to *a0*): Automatic operation mode selector:

<i>a1</i>	<i>a0</i>	Operation mode
0	0	Auto mode off (Strobe is controlled by microcontroller)
0	1	Runs only once after each power-up
1	0	Keep the $f_{offset}$ only during receiving (VDI=high)
1	1	Keep the $f_{offset}$ value independently from the state of the VDI signal

Bit 5-4 (*r1* to *r0*): Range limit. Limits the value of the frequency offset register to the next values:

<i>r1</i>	<i>r0</i>	Max deviation
0	0	No restriction
0	1	+15 $f_{res}$ to -16 $f_{res}$
1	0	+7 $f_{res}$ to -8 $f_{res}$
1	1	+3 $f_{res}$ to -4 $f_{res}$

$f_{res}$ :

433 MHz bands: 2.5 kHz

868 MHz band: 5 kHz

915 MHz band: 7.5 kHz

- Bit 3 (*st*): Strobe edge, when *st* goes to high, the actual latest calculated frequency error is stored into the offset register of the AFC block.
- Bit 2 (*fi*): Switches the circuit to high accuracy (fine) mode. In this case, the processing time is about twice as long, but the measurement uncertainty is about half.
- Bit 1 (*oe*): Enables the frequency offset register. It allows the addition of the offset register to the frequency control word of the PLL.
- Bit 0 (*en*): Enables the calculation of the offset frequency by the AFC circuit.

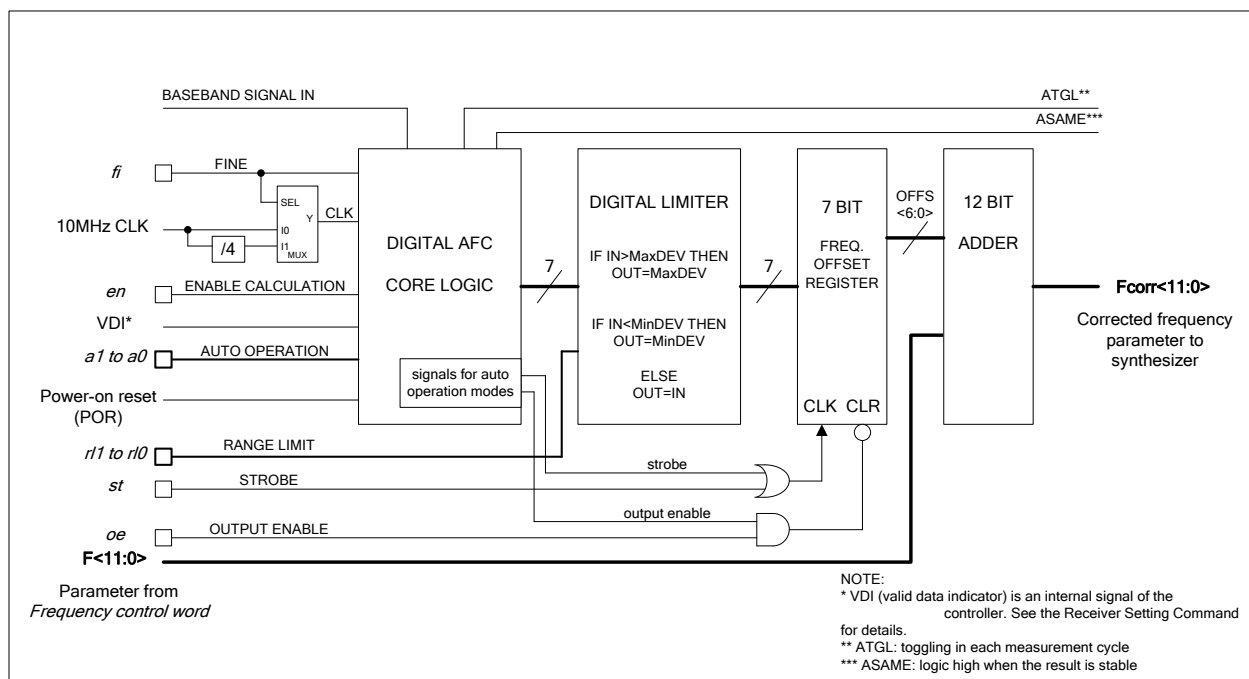

In manual mode, the strobe signal is provided by the microcontroller. One measurement cycle (and strobe) signal can compensate about 50-60% of the actual frequency offset. Two measurement cycles can compensate 80%, and three measurement cycles can compensate 92%. The ATGL bit in the status register can be used to determine when the actual measurement cycle is finished.

In automatic operation mode (no strobe signal is needed from the microcontroller to update the output offset register) the AFC circuit is automatically enabled when the VDI indicates potential incoming signal during the whole measurement cycle and the circuit measures the same result in two subsequent cycles.

Without AFC the transmitter and the receiver needs to be tuned precisely to the same frequency. RX/TX frequency offset can lower the range. The units must be adjusted carefully during production, stable, expensive crystal must be used to avoid drift or the output power needs to be increased to compensate yield loss.

The AFC block will calculate the TX-RX offset. This value will be used to pull the RX synthesizer close to the frequency of the transmitter. The main benefits of the automatic frequency control: cheap crystal can be used, the temperature or aging drift will not cause range loss and no production alignment needed.

There are four operation modes:

1. ( $a1=0$ ,  $a0=0$ ) Automatic operation of the AFC is off. Strobe bit can be controlled by the microcontroller.
2. ( $a1=0$ ,  $a0=1$ ) The circuit measures the frequency offset only once after power up. This way, extended TX-RX distance can be achieved. In the final application, when the user inserts the battery, the circuit measures and compensates for the frequency offset caused by the crystal tolerances. This method allows for the use of cheaper quartz in the application and provides protection against tracking an interferer.
3. ( $a1=1$ ,  $a0=0$ ) The frequency offset is calculated automatically and the center frequency is corrected when the VDI is high. The calculated value is dropped when the VDI goes low. To improve the efficiency of the AFC calculation two methods are recommended:
  - a. The transmit package should start with a low effective baud rate pattern (i.e.: 00110011) because it is easier to receive. The circuit automatically measures the frequency offset during this initial pattern and changes the receiving frequency accordingly. The further part of the package will be received by the corrected frequency settings.
  - b. The transmitter sends the first part of the packet with a step higher deviation than required during normal operation to ease the receiving. After the frequency shift was corrected, the deviation can be reduced.

In both cases (3a and 3b), when the VDI indicates poor receiving conditions (VDI goes low), the output register is automatically cleared. Use this “drop offset” mode when the receiver communicates with more than one transmitter.

4. ( $a1=1$ ,  $a0=1$ ) It is similar to mode 3, but suggested to use when a receiver operates with only one transmitter. After a complete measuring cycle, the measured value is kept independently of the state of the VDI signal. When the receiver is paired with only one transmitter, it is possible to use this “keep offset” mode. In this case, the DRSSI limit should be selected carefully to minimize the range hysteresis.

## 11. TX Configuration Control Command

Bit	15	14	13	12	11	10	9	8	7	6	5	4	3	2	1	0	POR
	1	0	0	1	1	0	0	mp	m3	m2	m1	m0	0	p2	p1	p0	9800h

Bits 8-4 ( $mp$ ,  $m3$  to  $m0$ ): FSK modulation parameters:

The resulting output frequency can be calculated as:

$$f_{out} = f_0 + (-1)^{SIGN} \cdot (M + 1) \cdot (15 \text{ kHz})$$

where:

$f_0$  is the channel center frequency (see the *Frequency Setting Command*)

$M$  is the four bit binary number  $\langle m3 : m0 \rangle$

$SIGN = (mp) \text{ XOR } FSK$

**Note:** For the optimal FSK modulation settings at different data rates see the table on page 38.

Bits 2-0 ( $p2$  to  $p0$ ): Output power:

$p2$	$p1$	$p0$	Relative Output Power [dB]
0	0	0	0
0	0	1	-2.5
0	1	0	-5
0	1	1	-7.5
1	0	0	-10
1	0	1	-12.5
1	1	0	-15
1	1	1	-17.5

**Note:** The output power given in the table is relative to the maximum available power, which depends on the actual antenna impedance. (See: Antenna Application Note: IA ISM-AN1)



**Note:** FSK represents the value of the actual data bit.



## 12. PLL Setting Command

Bit	15	14	13	12	11	10	9	8	7	6	5	4	3	2	1	0	POR
	1	1	0	0	1	1	0	0	0	ob1	ob0	1	dly	ddit	1	bw0	CC77h

Bits 6-5 (*ob1-ob0*): Microcontroller output clock buffer rise and fall time control. The *ob1-ob0* bits are changing the output drive current of the CLK pin. Higher current provides faster rise and fall times but can cause interference.

<i>ob1</i>	<i>ob0</i>	Selected $\mu$ C CLK frequency
1	1	5 or 10 MHz (recommended)
1	0	3.3 MHz
0	X	2.5 MHz or less

**Note:** Needed for optimization of the RF performance. Optimal settings can vary according to the external load capacitance.

Bit 3 (*dly*): Switches on the delay in the phase detector when this bit is set.

Bit 2 (*ddit*): When set, disables the dithering in the PLL loop.

Bit 0 (*bw0*): PLL bandwidth can be set for optimal TX RF performance.

<i>bw0</i>	Max bit rate [kbps]	Phase noise at 1MHz offset [dBc/Hz]
0	86.2	-107
1	256	-102

**Note:** POR default settings of the register were carefully selected to cover almost all typical applications. When changing these values, examine thoroughly the output RF spectrum. For more information, contact Silicon Labs Support.

## 13. Transmitter Register Write Command

Bit	15	14	13	12	11	10	9	8	7	6	5	4	3	2	1	0	POR
	1	0	1	1	1	0	0	0	t7	t6	t5	t4	t3	t2	t1	t0	B8AAh

With this command, the controller can write 8 bits (*t7* to *t0*) to the transmitter data register. Bit 7 (*e*) must be set in *Configuration Setting Command* (page 16).

### Multiple Byte Write with Transmit Register Write Command:



**Note:** Alternately the transmit register can be directly accessed by nFFS (pin6).

## 14. Wake-Up Timer Command

Bit	15	14	13	12	11	10	9	8	7	6	5	4	3	2	1	0	POR
	1	1	1	r4	r3	r2	r1	r0	m7	m6	m5	m4	m3	m2	m1	m0	E196h

The wake-up time period can be calculated by (*m7 to m0*) and (*r4 to r0*):

$$T_{\text{wake-up}} = 1.03 \cdot M \cdot 2^R + 0.5 \text{ [ms]}$$

### Note:

- For continual operation, the ew bit should be cleared and set at the end of every cycle.
- For future compatibility, use R in a range of 0 and 29.

## 15. Low Duty-Cycle Command

Bit	15	14	13	12	11	10	9	8	7	6	5	4	3	2	1	0	POR
	1	1	0	0	1	0	0	0	d6	d5	d4	d3	d2	d1	d0	en	C80Eh

With this command, autonomous low duty-cycle operation can be set in order to decrease the average power consumption in receive mode.

Bits 7-1 (*d6-d0*): The duty-cycle can be calculated by using (*d6 to d0*) and M. (M is parameter in a *Wake-Up Timer Command*, see above). The time cycle is determined by the *Wake-Up Timer Command*.

$$\text{duty-cycle} = (D \cdot 2 + 1) / M \cdot 100\%$$

Bit 0 (*en*): Enables the low duty-cycle Mode. Wake-up timer interrupt is not generated in this mode.

**Note:** In this operation mode, bit *er* must be cleared and bit *ew* must be set in the *Power Management Command* (page 16).

In low duty-cycle mode the receiver periodically wakes up for a short period of time and checks if there is a valid FSK transmission in progress. FSK transmission is detected in the frequency range determined by *Frequency Setting Command* (page 18) plus and minus the baseband filter bandwidth determined by the *Receiver Control Command* (page 18). This on-time is automatically extended while DQD indicates good received signal condition.

When calculating the on-time take into account:

- the crystal oscillator, the synthesizer and the PLL needs time to start, see the *AC Characteristics (Turn-on/Turnaround timings)* on page 12
- depending on the DQD parameter, the chip needs to receive a few valid data bits before the DQD signal indicates good signal condition (*Data Filter Command*, page 20)

Choosing too short on-time can prevent the crystal oscillator from starting or the DQD signal will not go high even when the received signal has good quality.

There is an application proposal on page 27. The Si4421 is configured to work in FIFO mode. The chip periodically wakes up and switches to receiving mode. If valid FSK data received, the chip sends an interrupt to the microcontroller and continues filling the RX FIFO. After the transmission is over and the FIFO is read out completely and all other interrupts are cleared, the chip goes back to low power consumption mode.

### Application Proposal for LPDM (Low Power Duty-Cycle Mode) Receivers:



## 16. Low Battery Detector and Microcontroller Clock Divider Command

Bit	15	14	13	12	11	10	9	8	7	6	5	4	3	2	1	0	POR
	1	1	0	0	0	0	0	0	d2	d1	d0	0	v3	v2	v1	v0	C000h

The 4-bit parameter (v3 to v0) represents the value V, which defines the threshold voltage  $V_{lb}$  of the detector:

$$V_{lb} = 2.25 + V \cdot 0.1 \text{ [V]}$$

Clock divider configuration:

d2	d1	d0	Clock Output Frequency [MHz]
0	0	0	1
0	0	1	1.25
0	1	0	1.66
0	1	1	2
1	0	0	2.5
1	0	1	3.33
1	1	0	5
1	1	1	10

The low battery detector and the clock output can be enabled or disabled by bits *eb* and *dc*, respectively, using the *Power Management Command* (page 16).

## 17. Status Read Command

Bit	15	14	13	12	11	10	9	8	7	6	5	4	3	2	1	0	POR
	0	0	0	0	0	0	0	0	0	0	0	0	0	0	0	0	0000h

The read command starts with a zero, whereas all other control commands start with a one. If a read command is identified, the status bits will be clocked out on the SDO pin as follows:

### Status Register Read Sequence with FIFO Read Example:



Bit Name	Function
RGIT	TX register is ready to receive the next byte (Can be cleared by <i>Transmitter Register Write Command</i> , page 25)
FFIT	The number of data bits in the RX FIFO has reached the pre-programmed limit (Can be cleared by any of the FIFO read methods)
POR	Power-on reset (Cleared after <i>Status Read Command</i> )
RGUR	TX register under run, register over write (Cleared after <i>Status Read Command</i> )
FFOV	RX FIFO overflow (Cleared after <i>Status Read Command</i> )
WKUP	Wake-up timer overflow (Cleared after <i>Status Read Command</i> )
EXT	Logic level on interrupt pin (pin 16) changed to low (Cleared after <i>Status Read Command</i> )
LBD	Low battery detect, the power supply voltage is below the pre-programmed limit
FFEM	FIFO is empty
ATS	Antenna tuning circuit detected strong enough RF signal
RSSI	The strength of the incoming signal is above the pre-programmed limit
DQD	Data quality detector output
CRL	Clock recovery locked
ATGL	Toggling in each AFC cycle
OFFS(6)	MSB of the measured frequency offset (sign of the offset value)
OFFS(3) -OFFS(0)	Offset value to be added to the value of the frequency control parameter (Four LSB bits)

**Note:** In order to get accurate values the AFC has to be disabled during the read by clearing the *en* bit in the *AFC Control Command* (page 22). The AFC offset value (OFFS bits in the status word) is represented as a two's complement number. The actual frequency offset can be calculated as the AFC offset value multiplied by the current PLL frequency step (see the *Frequency Setting Command* on page 18).

## INTERRUPT HANDLING

In order to achieve low power consumption there is an advanced event handling circuit implemented. The device has a very low power consumption mode, so called *sleep mode*. In this mode only a few parts of the circuit are working. In case of an event, the device wakes up, switches into active mode and an interrupt signal generated on the nIRQ pin to indicate the changed state to the microcontroller. The cause of the interrupt can be determined by reading the status word of the device (see *Status Read Command*, page 28).

Several interrupt sources are available:

- **RGIT** – TX register empty interrupt: This interrupt generated when the transmit register is empty. Valid only when the *el* (enable internal data register) bit is set in the *Configuration Setting Command* (page 16), and the transmitter is enabled in the *Power Management* command.
- **FFIT** – the number of bits in the RX FIFO reached the preprogrammed level: When the number of received data bits in the receiver FIFO reaches the threshold set by the *f3...f0* bits of the *FIFO and Reset Mode Command* (page 21) an interrupt is fired. Valid only when the *ef* (enable FIFO mode) bit is set in the *Configuration Setting Command* and the receiver is enabled in the *Power Management Command* (page 16).
- **POR** – power on reset interrupt: An interrupt generated when the change on the VDD line triggered the internal reset circuit or a software reset command was issued. For more details, see the *Reset Modes* section (page 35).
- **RGUR** – TX register under run: The automatic baud rate generator finished the transmission of the byte in the TX register before the register write occurred. Valid only when the *el* (enable internal data register) bit is set in the *Configuration Setting Command* and the transmitter is enabled in the *Power Management* command.
- **FFOV** – FIFO overflow: There are more bits received than the capacity of the FIFO (16 bits). Valid only when the *ef* (enable FIFO mode) bit is set in the *Configuration Setting Command* and the receiver is enabled in the *Power Management* command
- **WKUP** – wake-up timer interrupt: This interrupt event occurs when the time specified by the *Wake-Up Timer Command* (page 26) has elapsed. Valid only when the *ew* bit is set in the *Power Management Command*.
- **EXT** – external interrupt: Follows the level of the nINT pin if it is configured as an external Interrupt pin in the *Receiver Control Command* (page 18, *p16* bit is cleared).
- **LBD** – low battery detector interrupt: Occurs when the VDD goes below the programmable low battery detector threshold level (*v3...v0* bits in the *Low Battery and Microcontroller Clock Divider Command*, page 27). Valid only when the *eb* (enable low battery detector) bit is set in the *Power Management Command*.

If any of the sources becomes active, the nIRQ pin will change to logic low level, and the corresponding bit in the status byte will be HIGH.

Clearing an interrupt actually implies two things:

- Releasing the nIRQ pin to return to logic high
- Clearing the corresponding bit in the status byte

This may be completed with the following interrupt sources:

- **RGIT**: both the nIRQ pin and status bit remain active until the register is written (if under-run does not occur until the register write), or the transmitter and the TX latch are switched off.
- **FFIT**: both the nIRQ pin and status bit remain active until the FIFO is read (a FIFO IT threshold number of bits have been read), the receiver is switched off, or the RX FIFO is switched off.
- **POR**: both the nIRQ pin and status bit can be cleared by the read status command
- **RGUR**: this bit is always set together with RGIT; both the nIRQ pin and the status bit remain active until the transmitter and the TX latch is switched off.
- **FFOV**: this bit is always set together with FFIT; it can be cleared by the status read command, but the FFIT bit and hence the nIRQ pin will remain active until the FIFO is read fully, the receiver is switched off, or the RX FIFO is switched off.
- **WKUP**: both the nIRQ pin and status bit can be cleared by the read status command
- **EXT**: both the nIRQ pin and status bit follow the level of the nINT pin
- **LBD**: the nIRQ pin can be released by the reading the status, but the status bit will remain active while the VDD is below the threshold.

The best practice in interrupt handling is to start with a status read when interrupt occurs, and then make a decision based on the status byte. It is very important to mention that any interrupt can “wake-up” the EZradio chip from sleep mode. This means that the crystal oscillator starts to supply clock signal to the microcontroller even if the microcontroller has its own clock source. Also, the Si4421 will not go to low current sleep mode if any interrupt remains active regardless to the state of the *ex* (enable crystal oscillator) bit in the *Power Management Command* (page 16). This way the microcontroller always can have clock signal to process the interrupt. To prevent high current consumption and this way short battery life, it is strongly advised to process and clear every interrupt before going to sleep mode. All unnecessary functions should be turned off to avoid unwanted interrupts. Before freezing the microcontroller code, a thorough testing must be performed in order to make sure that all interrupt sources are handled before putting the radio device to low power consumption sleep mode. If the *dc* bit is set in the *Power Management Command*, then only the *ex* bit controls the crystal oscillator (supposing that both the *er* and *et* bits are cleared), the interrupts have no effect on it.

## TX REGISTER BUFFERED DATA TRANSMISSION

In this operating mode (enabled by bit *el*, in the *Configuration Setting Command*, page 16) the TX data is clocked into one of the two 8-bit data registers. The transmitter starts to send out the data from the first register (with the given bit rate) when bit *et* is set with the *Power Management Command* (page 16). The initial value of the data registers (AAh) can be used to generate preamble. During this mode, the SDO pin can be monitored to check whether the register is ready (SDO is high) to receive the next byte from the microcontroller.

TX register simplified block diagram (before transmit)



TX register simplified block diagram (during transmit)



## Typical TX register usage

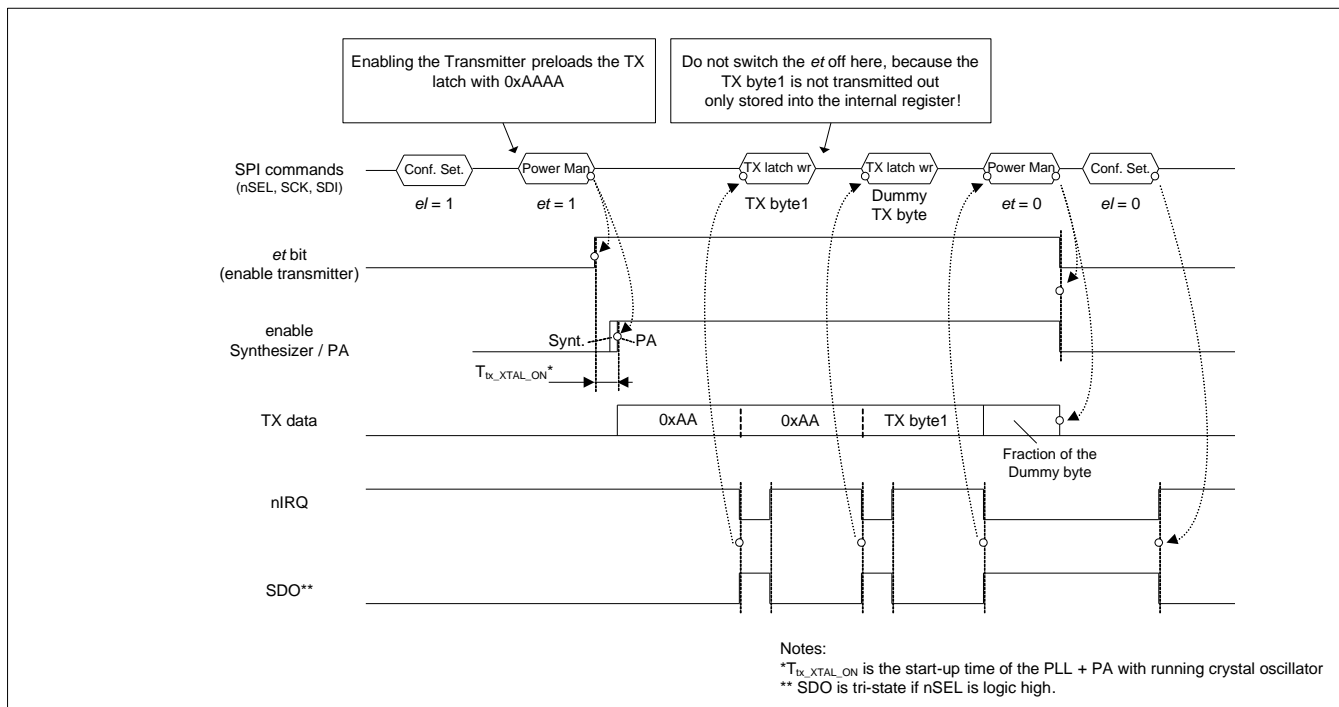

**Note:** The content of the data registers are initialized by clearing bit *et*.

A complete transmit sequence should be performed as follows:

- Enable the TX register by setting the *el* bit to 1 (*Configuration Setting Command*, page 16)
- The TX register automatically filled out with 0xAAAA, which can be used to generate preamble.
- Enable the transmitter by setting the *et* bit (*Power Management Command*, page 16)
- The synthesizer and the PLL turns on, calibrates itself then the power amplifier automatically enabled
- The TX data transmission starts
- When the transmission of the byte completed, the nIRQ pin goes high, the SDO pin goes low at the same time. The nIRQ pulse shows that the first 8 bits (the first byte, by default 0xAA) has transmitted. There are still 8 bits in the transmit register.
- The microcontroller recognizes the interrupt and writes a data byte to the TX register
- Repeat f. - g. until the last data byte reached
- Using the same method, transmit a dummy byte. The value of this dummy byte can be anything.
- The next high to low transition on the nIRQ line (or low to high on the SDO pin) shows that the transmission of the data bytes ended. The dummy byte is still in the TX latch.
- Turn off the transmitter by setting the *et* bit to 0. This event will probably happen while the dummy byte is being transmitted. Since the dummy byte contains no useful information, this corruption will cause no problems.
- Clearing the *el* bit clears the Register Underrun interrupt; the nIRQ pin goes high, the SDO low.

It is possible to perform this sequence without sending a dummy byte (step i.) but after loading the last data byte to the transmit register the PA turn off should be delayed for at least 16 bits time. The clock source of the microcontroller (if the clock is not supplied by the Si4421) should be stable enough over temperature and voltage to ensure this minimum delay under all operating circumstances.

When the dummy byte is used, the whole process is driven by interrupts. Changing the TX data rate has no effect on the algorithm and no accurate delay measurement is needed.

## RX FIFO BUFFERED DATA READ

In this operating mode, incoming data are clocked into a 16-bit FIFO buffer. The receiver starts to fill up the FIFO when the Valid Data Indicator (VDI) bit and the synchron pattern recognition circuit indicates potentially real incoming data. This prevents the FIFO from being filled with noise and overloading the external microcontroller.

### Interrupt Controlled Mode:

The user can define the FIFO IT level (the number of received bits) which will generate the nFFIT when exceeded. The status bits report the changed FIFO status in this case.

### Polling Mode:

When nFFS signal is low the FIFO output is connected directly to the SDO pin and its content can be clocked out by the SCK. Set the FIFO IT level to 1. In this case, as long as FFIT indicates received bits in the FIFO, the controller may continue to take the bits away. When FFIT goes low, no more bits need to be taken.

An SPI read command is also available to read out the content of the FIFO (*Receiver FIFO Read Command*, page 22).

### FIFO Read Example with FFIT Polling

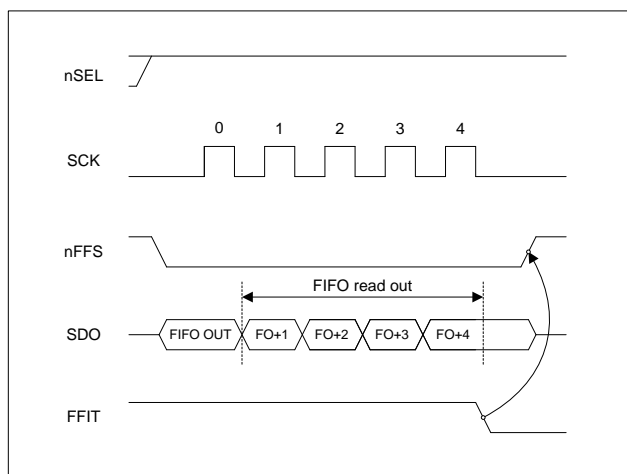

**Note:** During FIFO access  $f_{SCK}$  cannot be higher than  $f_{ref}/4$ , where  $f_{ref}$  is the crystal oscillator frequency. When the duty-cycle of the clock signal is not 50% the shorter period of the clock pulse should be at least  $2/f_{ref}$ .

## RECOMMENDED PACKET STRUCTURES

	Preamble	Synchron word (Can be network ID)	Payload	CRC
Minimum length	4 - 8 bits (1010b or 0101b)	D4h (programmable)	?	4 bit - 1 byte
Recommended length	8 -12 bits (e.g. AAh or 55h)	2DD4h (D4 is programmable)	?	2 byte



## CRYSTAL SELECTION GUIDELINES

The crystal oscillator of the Si4421 requires a 10 MHz parallel mode crystal. The circuit contains an integrated load capacitor in order to minimize the external component count. The internal load capacitance value is programmable from 8.5 pF to 16 pF in 0.5 pF steps. With appropriate PCB layout, the total load capacitance value can be 10 pF to 20 pF so a variety of crystal types can be used.

When the total load capacitance is not more than 20 pF and a worst case 7 pF shunt capacitance ( $C_0$ ) value is expected for the crystal, the oscillator is able to start up with any crystal having less than 100 ohms ESR (equivalent series loss resistance). However, lower  $C_0$  and ESR values guarantee faster oscillator startup.

The crystal frequency is used as the reference of the PLL, which generates the local oscillator frequency ( $f_{LO}$ ). Therefore,  $f_{LO}$  is directly proportional to the crystal frequency. The accuracy requirements for production tolerance, temperature drift and aging can thus be determined from the maximum allowable local oscillator frequency error.

Whenever a low frequency error is essential for the application, it is possible to “pull” the crystal to the accurate frequency by changing the load capacitor value. The widest pulling range can be achieved if the nominal required load capacitance of the crystal is in the “midrange”, for example 16 pF. The “pull-ability” of the crystal is defined by its motional capacitance and  $C_0$ .

### Maximum XTAL Tolerances Including Temperature and Aging [ppm]

#### Bit Rate: 2.4 kbps

	Deviation [ $\pm$ kHz]						
	30	45	60	75	90	105	120
433 MHz	20	30	50	70	90	100	100
868 MHz	10	20	25	30	40	50	60
915 MHz	10	15	25	30	40	50	50

#### Bit Rate: 9.6 kbps

	Deviation [ $\pm$ kHz]						
	30	45	60	75	90	105	120
433 MHz	15	30	50	70	80	100	100
868 MHz	8	15	25	30	40	50	60
915 MHz	8	15	25	30	40	50	50

#### Bit Rate: 38.4 kbps

	Deviation [ $\pm$ kHz]						
	30	45	60	75	90	105	120
433 MHz	don't use	5	20	30	50	75	75
868 MHz	don't use	3	10	20	25	30	40
915 MHz	don't use	3	10	15	25	30	40

#### Bit Rate: 115.2 kbps

	Deviation [ $\pm$ kHz]						
	105	120	135	150	165	180	195
433 MHz	don't use	3	20	30	50	70	80
868 MHz	don't use	don't use	10	20	25	35	45
915 MHz	don't use	don't use	10	15	25	30	40

## **RX-TX ALIGNMENT PROCEDURES**

RX-TX frequency offset can be caused only by the differences in the actual reference frequency. To minimize these errors it is suggested to use the same crystal type and the same PCB layout for the crystal placement on the RX and TX PCBs.

To verify the possible RX-TX offset it is suggested to measure the CLK output of both chips with a high level of accuracy. Do not measure the output at the XTL pin since the measurement process itself will change the reference frequency. Since the carrier frequencies are derived from the reference frequency, having identical reference frequencies and nominal frequency settings at the TX and RX side there should be no offset if the CLK signals have identical frequencies.

It is possible to monitor the actual RX-TX offset using the AFC status report included in the status byte of the receiver. By reading out the status byte from the receiver, the actual measured offset frequency will be reported. In order to get accurate values the AFC has to be disabled during the read by clearing the *en* bit in the *AFC Control Command* (page 22).

## RESET MODES

The chip will enter into reset mode if any of the following conditions are met:

- Power-on reset: During a power up sequence until the  $V_{dd}$  has reached the correct level and stabilized
- Power glitch reset: Transients present on the  $V_{dd}$  line
- Software reset: Special control command received by the chip

### Power-on reset

After power up the supply voltage starts to rise from 0V. The reset block has an internal ramping voltage reference (reset-ramp signal), which is rising at 100mV/ms (typical) rate. The chip remains in reset state while the voltage difference between the actual  $V_{dd}$  and the internal reset-ramp signal is higher than the reset threshold voltage, which is 600 mV (typical). As long as the  $V_{dd}$  voltage is less than 1.6V (typical) the chip stays in reset mode regardless the voltage difference between the  $V_{dd}$  and the internal ramp signal.

The reset event can last up to 100ms supposing that the  $V_{dd}$  reaches 90% its final value within 1ms. During this period, the chip does not accept control commands via the serial control interface.

Power-on reset example:

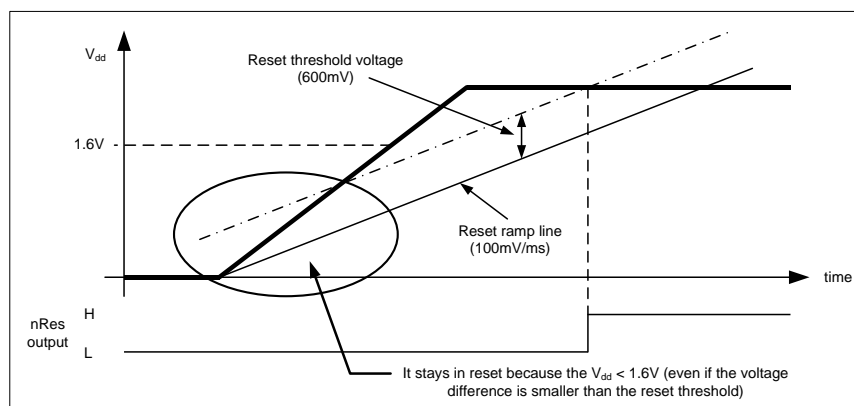

### Power glitch reset

The internal reset block has two basic mode of operation: normal and sensitive reset. The default mode is sensitive, which can be changed by the appropriate control command (see *Related control commands* at the end of this section). In normal mode the power glitch detection circuit is disabled.

There can be spikes or glitches on the  $V_{dd}$  line if the supply filtering is not satisfactory or the internal resistance of the power supply is too high. In such cases if the sensitive reset is enabled an (unwanted) reset will be generated if the positive going edge of the  $V_{dd}$  has a rising rate greater than 100mV/ms and the voltage difference between the internal ramp signal and the  $V_{dd}$  reaches the reset threshold voltage (600 mV). Typical case when the battery is weak and due to its increased internal resistance a sudden decrease of the current consumption (for example turning off the power amplifier) might lead to an increase in supply voltage. If for some reason the sensitive reset cannot be disabled step-by-step decrease of the current consumption (by turning off the different stages one by one) can help to avoid this problem.

Any negative change in the supply voltage will not cause reset event unless the  $V_{dd}$  level reaches the reset threshold voltage (250mV in normal mode, 1.6V in sensitive reset mode).

If the sensitive mode is disabled and the power supply turned off the  $V_{dd}$  must drop below 250mV in order to trigger a power-on reset event when the supply voltage is turned back on. If the decoupling capacitors keep their charges for a long time it could happen that no reset will be generated upon power-up because the power glitch detector circuit is disabled.

Note that the reset event reinitializes the internal registers, so the sensitive mode will be enabled again.

Sensitive Reset Enabled, Ripple on  $V_{dd}$ :



Sensitive reset disabled:



### Software reset

Software reset can be issued by sending the appropriate control command (described at the end of the section) to the chip. The result of the command is the same as if power-on reset was occurred but the length of the reset event is much less, 0.25ms typical. The software reset works only when the sensitive reset mode is selected.

### $V_{dd}$ line filtering

During the reset event (caused by power-on, fast positive spike on the supply line or software reset command), it is very important to keep the  $V_{dd}$  line as smooth as possible. Noise or periodic disturbing signal superimposed on the supply voltage may prevent the part getting out from reset state. To avoid this phenomenon use adequate filtering on the power supply line to keep the level of the disturbing signal below 100mV<sub>p-p</sub> in the DC - 50kHz range for 200ms from  $V_{dd}$  ramp start. Typical example when a switch-mode regulator is used to supply the radio, switching noise may be present on the  $V_{dd}$  line. Follow the manufacturer's recommendations how to decrease the ripple of the regulator IC and/or how to shift the switching frequency.

### Related control commands

*FIFO and Reset Mode Command* (page 21)

Setting bit<0> to high will change the reset mode to normal from the default sensitive.

*SW Reset Command*

Issuing FE00h command will trigger software reset (sensitive reset mode must be enabled). See the *Wake-up Timer Command* (page 26).

## TYPICAL PERFORMANCE CHARACTERISTICS

### Channel Selectivity and Blocking:

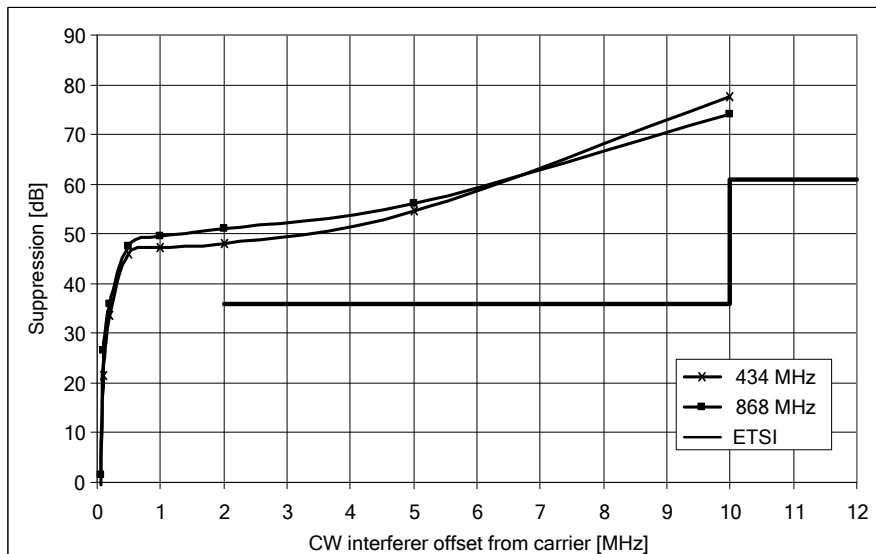

#### Note:

- LNA gain maximum, filter bandwidth 67 kHz, data rate 9.6 kbps, AFC switched off, FSK deviation  $\pm 45$  kHz,  $V_{dd} = 2.7$  V
- Measured according to the descriptions in the ETSI Standard EN 300 220-1 v2.1.1 (2006-01 Final Draft), section 9
- The ETSI limit given in the figure is drawn by taking -106dBm at 9.6kbps typical sensitivity into account, and corresponds to receiver class 2 requirements (section 4.1.1)

### Phase Noise Performance in the 433, 868 and 915 MHz Bands:

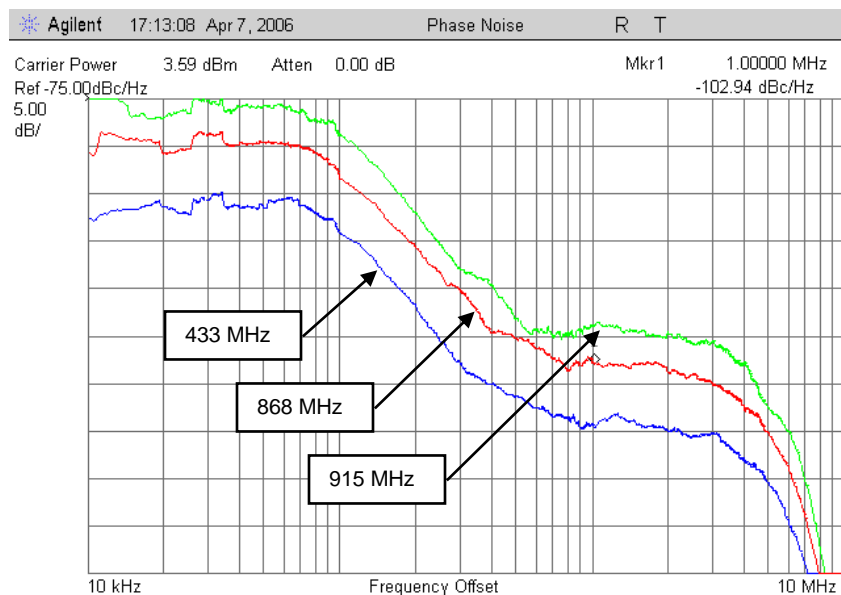

(Measured under typical conditions:  $T_{op} = 27$  °C;  $V_{dd} = V_{oc} = 2.7$  V)

**BER Curves in 433 MHz Band:****BER Curves in 868 MHz Band:**

The table below shows the optimal receiver baseband bandwidth (BW) and transmitter deviation frequency ( $\delta f_{FSK}$ ) settings for different data-rates supposing no transmit receive offset frequency. If TX/RX offset (for example due to crystal tolerances) have to be taken into account, increase the BW accordingly.

1.2 kbps	2.4 kbps	4.8 kbps	9.6 kbps	19.2 kbps	38.4 kbps	57.6 kbps	115.2 kbps
BW=67 kHz $\delta f_{FSK}$ =45 kHz	BW=67 kHz $\delta f_{FSK}$ =45 kHz	BW=67 kHz $\delta f_{FSK}$ =45kHz	BW=67 kHz $\delta f_{FSK}$ =45 kHz	BW=67 kHz $\delta f_{FSK}$ =45 kHz	BW=134 kHz $\delta f_{FSK}$ =90 kHz	BW=134 kHz $\delta f_{FSK}$ =90 kHz	BW=200 kHz $\delta f_{FSK}$ =120 kHz

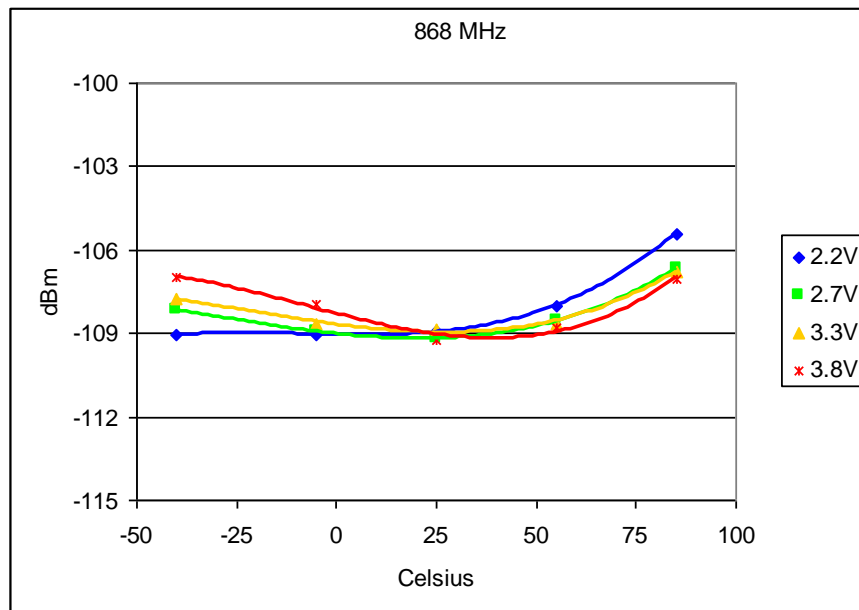
**Receiver Sensitivity over Ambient Temperature (433 MHz, 2.4 kbps,  $\delta f_{FSK}$ : 45 kHz, BW: 67 kHz):****Receiver Sensitivity over Ambient Temperature (868 MHz, 2.4 kbps,  $\delta f_{FSK}$ : 45 kHz, BW: 67 kHz):**

## REFERENCE DESIGNS

### Evaluation Board with 50 Ohm Matching Network

#### Schematics



#### Frequency Dependent Component Values

f [MHz]	L1 [nH]	L2 [nH]	L3 [nH]	L4 [nH]	C8 [pF]	C9 [pF]	C10 [pF]	C11 [pF]	C3 [pF]
434	18	47	390	18	5	2.7	2.7	220	220
868	3.9	18	100	3.9	2.7	1.2	1.8	47	47
915	3.6	16	100	3.6	2.7	1.2	1.8	33	33

#### Recommended Component Types

Component	Manufacturer	Part number			Note
		434MHz	868 MHz	915MHz	
L1	Coilcraft	0603CS-18NX	0603CS-3N9X	0603CS-3N9X	1
L4	Coilcraft	0603CS-18NX	0603CS-3N9X	0603CS-3N9X	1
L2	Coilcraft	0603CS-47NX	0603CS-18NX	0603CS-16NX	1
L3	Coilcraft	0603CS-R39X	0603CS-R10X	0603CS-R10X	2
C9	Murata	GRM1885C1H2R7CZ01B	GRM1885C1H1R2CZ01B	GRM1885C1H1R2CZ01B	3
C8	Murata	GRM1885C1H5R0CZ01B	GRM1885C1H2R7CZ01B	GRM1885C1H2R7CZ01B	3
C10	Murata	GRM1885C1H2R7CZ01B	GRM1885C1H1R8CZ01B	GRM1885C1H1R8CZ01B	3, 4
C11	Murata	GRM1885C1H221JA01B	GRM1885C1H470JZ01B	GRM1885C1H330JZ01B	3
C3	Murata	GRM1885C1H221JA01B	GRM1885C1H470JZ01B	GRM1885C1H330JZ01B	3

For component selection guidelines, see the notes on the next page.



## Notes:

1. SRF, DCR and Q should be similar if components from other manufacturer used
2. The SRF should be twice as much as the operation frequency
3. The dielectric type should be COG and the resonant frequency should be similar if components from alternative vendor used.
4. The values are valid for 1.5mm thick FR4 PCB. If thinner board used the capacitor value should be increased (and vice versa) to minimize the level of the second harmonic components.

## PCB Layout



Top View



Bottom View

## Evaluation Board with Resonant PCB Antenna (BIFA)

### Schematics



**Note:** Components R5 to R8 and C6 are needed for connection to the ISM Chipset Development Kit load board (IA ISM-DK3) and are not necessary in an application.

### Frequency Dependent Component Values

Band	C3 [pF]	L1 [nH]
868 MHz	47	22
Dual (868/915 MHz)	47/33	18
915 MHz	33	15

PCB Layout (Antenna designed for 868/915 MHz band)

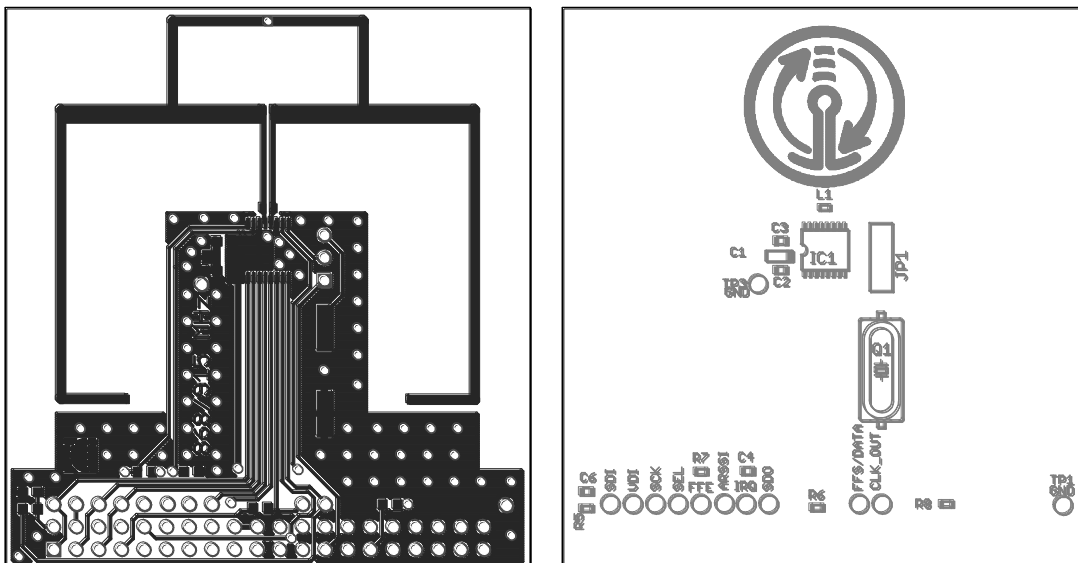

Top View

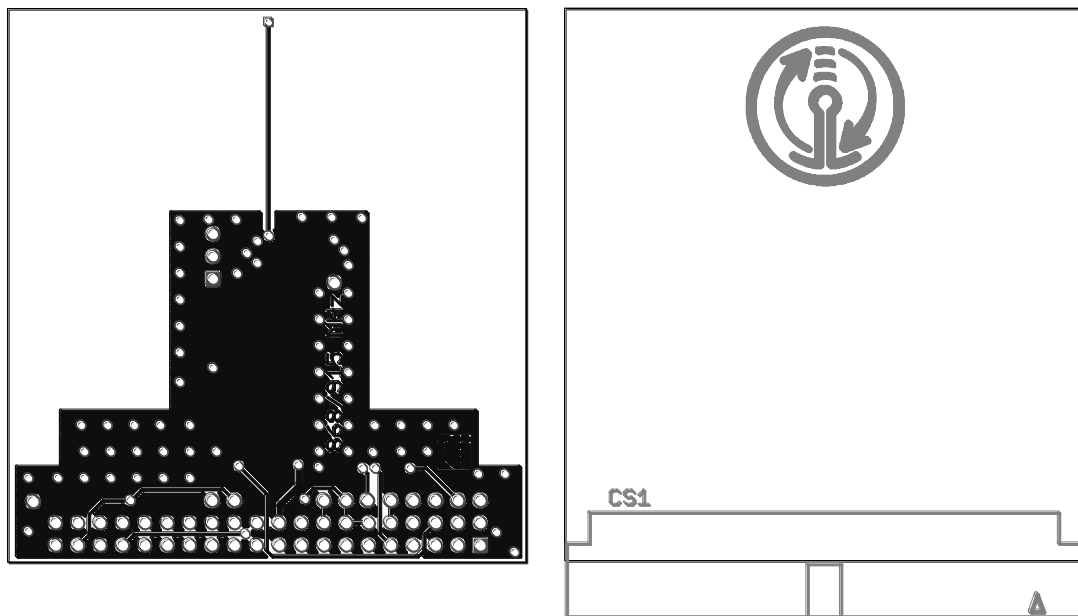

Bottom View

## PACKAGE INFORMATION

## 16-pin TSSOP

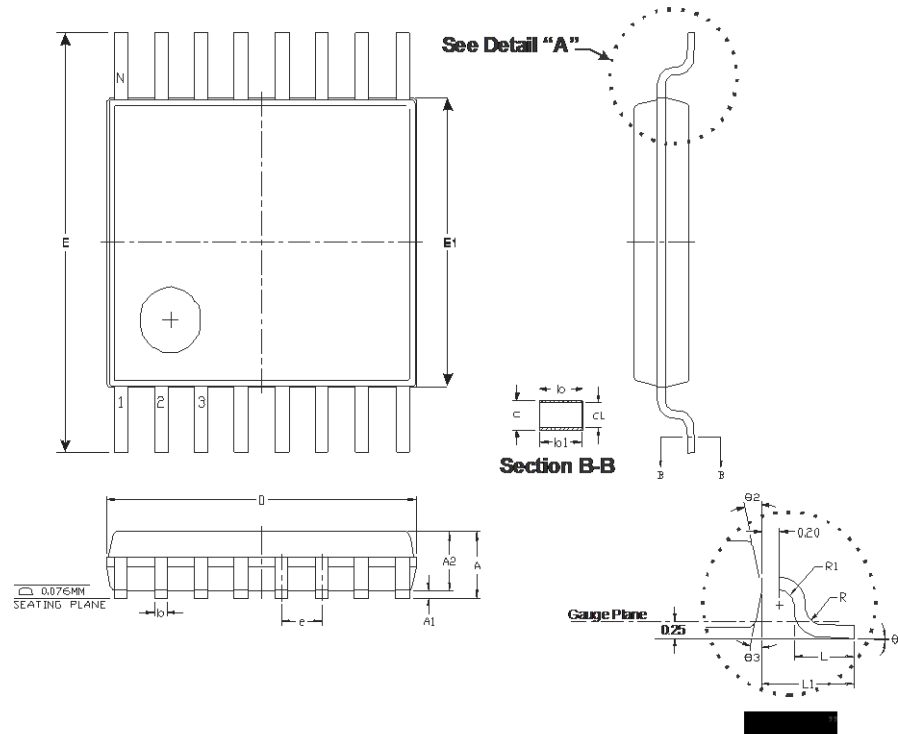

Symbol	Dimensions in mm			Dimensions in Inches		
	Min.	Nom.	Max.	Min.	Nom.	Max.
A			1,20			0,047
A1	0,05		0,15	0,002		0,006
A2	0,80	0,90	1,05	0,031	0,035	0,041
b	0,19		0,30	0,007		0,012
b1	0,19	0,22	0,25	0,007	0,009	0,010
c	0,09		0,20	0,004		0,008
c1	0,09		0,16	0,004		0,006
D	4,90	5,00	5,10	0,193	0,197	0,201
e	0.65 BSC.			0.026 BSC.		
E	6.40 BSC.			0.252 BSC.		
E1	4,30	4,40	4,50	0,169	0,173	0,177
L	0,50	0,60	0,75	0,020	0,024	0,030
L1	1.00 REF.			0.39 REF.		
R	0,09			0,004		
R1	0,09			0,004		
θ1	0		8	0		8
θ2	12 REF.			12 REF.		
θ3	12 REF.			12 REF.		

## RELATED PRODUCTS AND DOCUMENTS

### Si4421 Universal ISM Band FSK Transceiver

DESCRIPTION	ORDERING NUMBER
Si4421 16-pin TSSOP	Si4421-IC CC16 Revision # A1

### Demo Boards and Development Kits

DESCRIPTION	ORDERING NUMBER
Development Kit	IA ISM – DK
ISM Repeater Demo	IA ISM – DARP

### Related Resources

DESCRIPTION	ORDERING NUMBER
Antenna Selection Guide	IA ISM – AN1
Antenna Development Guide	IA ISM – AN2
Si4221 Universal ISM Band FSK Transmitter	See <a href="http://www.silabs.com">www.silabs.com</a> for details
Si4320 Universal ISM Band FSK Receiver	See <a href="http://www.silabs.com">www.silabs.com</a> for details

**Note: Volume orders must include chip revision to be accepted.**

IAI provides technical support ONLY through its on-line support system: [http://www.silabs.com/integration/d\\_Technical.php](http://www.silabs.com/integration/d_Technical.php). Please contact our support team by filling out the online query submission, a representative will reply within 2-3 working days.

<p>Silicon Labs, Inc. 400 West Cesar Chavez Austin, Texas 78701 Tel: 512.416.8500 Fax: 512.416.9669 Toll Free: 877.444.3032 <a href="http://www.silabs.com">www.silabs.com</a> <a href="mailto:wireless@silabs.com">wireless@silabs.com</a></p>	<p>The specifications and descriptions in this document are based on information available at the time of publication and are subject to change without notice. Silicon Laboratories assumes no responsibility for errors or omissions, and disclaims responsibility for any consequences resulting from the use of information included herein. Additionally, Silicon Laboratories assumes no responsibility for the functioning of undescribed features or parameters. Silicon Laboratories reserves the right to make changes to the product and its documentation at any time. Silicon Laboratories makes no representations, warranties, or guarantees regarding the suitability of its products for any particular purpose and does not assume any liability arising out of the application or use of any product or circuit, and specifically disclaims any and all liability for consequential or incidental damages arising out of use or failure of the product. Nothing in this document shall operate as an express or implied license or indemnity under the intellectual property rights of Silicon Laboratories or third parties. The products described in this document are not intended for use in implantation or other direct life support applications where malfunction may result in the direct physical harm or injury to persons. NO WARRANTIES OF ANY KIND, INCLUDING BUT NOT LIMITED TO, THE IMPLIED WARRANTIES OF MERCHANTABILITY OR FITNESS FOR A PARTICULAR PURPOSE, ARE OFFERED IN THIS DOCUMENT.</p> <p><small>©2008 Silicon Laboratories, Inc. All rights reserved. Silicon Laboratories is a trademark of Silicon Laboratories, Inc. All other trademarks belong to their respective owners.</small></p>
-----------------------------------------------------------------------------------------------------------------------------------------------------------------------------------------------------------------------------------------------------------------------------	--------------------------------------------------------------------------------------------------------------------------------------------------------------------------------------------------------------------------------------------------------------------------------------------------------------------------------------------------------------------------------------------------------------------------------------------------------------------------------------------------------------------------------------------------------------------------------------------------------------------------------------------------------------------------------------------------------------------------------------------------------------------------------------------------------------------------------------------------------------------------------------------------------------------------------------------------------------------------------------------------------------------------------------------------------------------------------------------------------------------------------------------------------------------------------------------------------------------------------------------------------------------------------------------------------------------------------------------------------------------------------------------------------------------------------------------------------------------------------------------------------------------------------------------------------------------------------------------------------------------------------------------------------------------------------------------------------------------------------------------



Smart.  
Connected.  
Energy-Friendly



**Products**  
[www.silabs.com/products](http://www.silabs.com/products)



**Quality**  
[www.silabs.com/quality](http://www.silabs.com/quality)



**Support and Community**  
[community.silabs.com](http://community.silabs.com)

**Disclaimer**

Silicon Laboratories intends to provide customers with the latest, accurate, and in-depth documentation of all peripherals and modules available for system and software implementers using or intending to use the Silicon Laboratories products. Characterization data, available modules and peripherals, memory sizes and memory addresses refer to each specific device, and "Typical" parameters provided can and do vary in different applications. Application examples described herein are for illustrative purposes only. Silicon Laboratories reserves the right to make changes without further notice and limitation to product information, specifications, and descriptions herein, and does not give warranties as to the accuracy or completeness of the included information. Silicon Laboratories shall have no liability for the consequences of use of the information supplied herein. This document does not imply or express copyright licenses granted hereunder to design or fabricate any integrated circuits. The products are not designed or authorized to be used within any Life Support System without the specific written consent of Silicon Laboratories. A "Life Support System" is any product or system intended to support or sustain life and/or health, which, if it fails, can be reasonably expected to result in significant personal injury or death. Silicon Laboratories products are not designed or authorized for military applications. Silicon Laboratories products shall under no circumstances be used in weapons of mass destruction including (but not limited to) nuclear, biological or chemical weapons, or missiles capable of delivering such weapons.

**Trademark Information**

Silicon Laboratories Inc.®, Silicon Laboratories®, Silicon Labs®, SiLabs® and the Silicon Labs logo®, Bluegiga®, Bluegiga Logo®, Clockbuilder®, CMEMS®, DSPLL®, EFM®, EFM32®, EFR®, Ember®, Energy Micro, Energy Micro logo and combinations thereof, "the world's most energy friendly microcontrollers", Ember®, EZLink®, EZRadio®, EZRadioPRO®, Gecko®, ISOModem®, Precision32®, ProSLIC®, Simplicity Studio®, SiPHY®, Telegesis, the Telegesis Logo®, USBXpress® and others are trademarks or registered trademarks of Silicon Laboratories Inc. ARM, CORTEX, Cortex-M3 and THUMB are trademarks or registered trademarks of ARM Holdings. Keil is a registered trademark of ARM Limited. All other products or brand names mentioned herein are trademarks of their respective holders.



Silicon Laboratories Inc.  
400 West Cesar Chavez  
Austin, TX 78701  
USA

<http://www.silabs.com>

## Данный компонент на территории Российской Федерации

### Вы можете приобрести в компании MosChip.

Для оперативного оформления запроса Вам необходимо перейти по данной ссылке:

<http://moschip.ru/get-element>

Вы можете разместить у нас заказ для любого Вашего проекта, будь то серийное производство или разработка единичного прибора.

В нашем ассортименте представлены ведущие мировые производители активных и пассивных электронных компонентов.

Нашей специализацией является поставка электронной компонентной базы двойного назначения, продукции таких производителей как XILINX, Intel (ex.ALTERA), Vicor, Microchip, Texas Instruments, Analog Devices, Mini-Circuits, Amphenol, Glenair.

Сотрудничество с глобальными дистрибьюторами электронных компонентов, предоставляет возможность заказывать и получать с международных складов практически любой перечень компонентов в оптимальные для Вас сроки.

На всех этапах разработки и производства наши партнеры могут получить квалифицированную поддержку опытных инженеров.

Система менеджмента качества компании отвечает требованиям в соответствии с ГОСТ Р ИСО 9001, ГОСТ РВ 0015-002 и ЭС РД 009

### Офис по работе с юридическими лицами:

105318, г.Москва, ул.Щербаковская д.3, офис 1107, 1118, ДЦ «Щербаковский»

Телефон: +7 495 668-12-70 (многоканальный)

Факс: +7 495 668-12-70 (доб.304)

E-mail: [info@moschip.ru](mailto:info@moschip.ru)

Skype отдела продаж:

moschip.ru

moschip.ru\_4

moschip.ru\_6

moschip.ru\_9