



## **GLASS WIRE WOUND SENSOR TYPE GO**

RTD Temperature Sensor

### SPECIFICATIONS

- Temperature sensor
- Large temperature range  
From -200°C to +400°C
- High vibrations resistant
- Resistant to external forces and pressures
- Small dimensions
- Good temperature stability
- Abrasion resistance
- Good pull up force resistance of leads
- Resistance to aggressive environment (acid, oil, solvent)

One or two platinum bands wounded on solid glass core and homogeneously sealed with external tube.

### FEATURES

- Nominal Value: 100  $\Omega$  at 0°C  
Tolerance according to IEC 60751: class W 0.3, W 0.15 and W 0.1  
Temperature coefficient  $\alpha = 3850$  ppm/K  
Closer tolerances in restricted temperature ranges
- Connection Wires: Platinum coated nickel wires
- The lead wires connection is pull up force resistant
- Housing Advise: Can be used in most of liquids without protection (water, oil, solvent, acid...).
- Options: - Lead wires length
  - Extension cable
  - Glass shape (diameter, length, bent)
  - Ohmic values

### APPLICATIONS

- Chemical and pharmaceutical industry
- Food industry
- H.V.A.C.
- Power generation plants
- Analytical equipment
- Aerospace industry
- Marine...

## GLASS WIRE WOUND SENSOR TYPE GO

RTD Temperature Sensor

### PERFORMANCE SPECIFICATIONS

Type	Designation	Reference	Nominal reference (Ohm at 0°C)	L WL D AL1 AL2 A (Dimensions in mm)					Self-heating in air (K/mW)	Response time (s)				
				Water v = 0,4 m/s		Air v = 1 m/s								
									t0,5	t0,9	t0,5	t0,9		
<b>Tolerance Class W 0.3 = ± (0.3+0.005 Itl) From -196°C to + 400°C</b>														
1Pt100	GO 1020	SB0789	100	10	6	2,0	15	-	0,25	0,26	0,14	0,35	7	21
1Pt100	GO 1327	SB0865	100	13	9	2,7	15	-	0,25	0,11	0,40	1,30	13	25
1Pt100	GO 1545	SB0862	100	15	9,5	4,5	15	-	0,25	0,09	0,80	2,40	16	40
1Pt100	GO 2327	SB0870	100	23	16	2,7	15	-	0,25	0,11	0,40	1,30	13	25
1Pt100	GO 3045	SB0873	100	30	21	4,5	15	-	0,25	0,09	0,80	2,40	16	40
2Pt100	GO 4845	SB0765	100	48	35	4,5	10	12	0,25	0,09	0,80	2,40	16	40
<b>Tolerance Class W 0.15 = ± (0.15+0.002 Itl) From -100°C to + 250°C</b>														
1Pt100	GO 1020	SB0794	100	10	6	2,0	15	-	0,25	0,26	0,14	0,35	7	21
1Pt100	GO 1327	SB0866	100	13	9	2,7	15	-	0,25	0,11	0,40	1,30	13	25
1Pt100	GO 1545	SB0863	100	15	9,5	4,5	15	-	0,25	0,09	0,80	2,40	16	40
1Pt100	GO 2327	SB0871	100	23	16	2,7	15	-	0,25	0,11	0,40	1,30	13	25
1Pt100	GO 3045	SB0874	100	30	21	4,5	15	-	0,25	0,09	0,80	2,40	16	40
<b>Tolerance Class W 0.1 = ± (0.1+0.0017 Itl) From 0°C to + 150°C</b>														
1Pt100	GO 1020	SB0795	100	10	6	2,0	15	-	0,25	0,26	0,14	0,35	7	21
1Pt100	GO 1327	SB0867	100	13	9	2,7	15	-	0,25	0,11	0,40	1,30	13	25
1Pt100	GO 1545	SB0864	100	15	9,5	4,5	15	-	0,25	0,09	0,80	2,40	16	40
1Pt100	GO 2327	SB0872	100	23	16	2,7	15	-	0,25	0,11	0,40	1,30	13	25
1Pt100	GO 3045	SB0875	100	30	21	4,5	15	-	0,25	0,09	0,80	2,40	16	40

### VALUES FOR Pt100

°C	Ohms	Ohms/°C	°C	Ohms	Ohms/°C
-200	18.52	0.432	150	157.33	0.374
-150	39.72	0.417	200	175.86	0.368
-100	60.26	0.405	250	194.10	0.362
-50	80.31	0.397	300	212.05	0.356
0	100	0.391	350	229.72	0.350
50	119.40	0.385	400	247.09	0.345
100	138.51	0.379			

## GLASS WIRE WOUND SENSOR TYPE GO

RTD Temperature Sensor

### BLOCK DIAGRAM

DIMENSIONAL TOLERANCES:

L	(length of body)	= ± 2mm
D	(diameter of body)	= ± 0.2mm
AL	(connection wire length)	= ± 2mm
A	(connection wire diameter)	= ± 0.02 mm

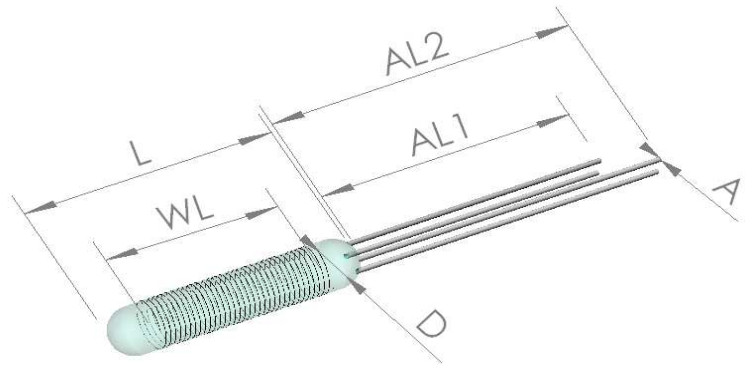

### ORDERING INFORMATION

#### NORTH AMERICA

Measurement Specialties, Inc.,  
a TE Connectivity Company  
910 Turnpike Road  
Shrewsbury, MA 01545  
United States  
+1 508-842-0516  
+1 508-842-0342  
temperature.cs.amer@meas-spec.com

#### EUROPE

Measurement Specialties (Europe), Ltd.,  
a TE Connectivity Company  
48, rue de Frégy  
77610 Fontenay Trésigny  
France  
Tel: +33(0) 1 64 42 52 52  
Fax: +33(0) 1 64 42 63 17  
sales.ftny.fr@meas-spec.com

#### ASIA

Measurement Specialties (China), Ltd.,  
a TE Connectivity Company  
No. 26 Langshan Road  
Shenzhen High-Tech Park (North)  
Nanshan District, Shenzhen 518057  
China  
Tel: +86 755 3330 5088  
Fax: +86 755 3330 5099  
temperature.cs.asia@meas-spec.com

#### TE.com/sensorsolutions

Measurement Specialties, Inc., a TE Connectivity company.

Measurement Specialties, TE Connectivity, TE Connectivity (logo) and EVERY CONNECTION COUNTS are trademarks. All other logos, products and/or company names referred to herein might be trademarks of their respective owners.

The information given herein, including drawings, illustrations and schematics which are intended for illustration purposes only, is believed to be reliable. However, TE Connectivity makes no warranties as to its accuracy or completeness and disclaims any liability in connection with its use. TE Connectivity's obligations shall only be as set forth in TE Connectivity's Standard Terms and Conditions of Sale for this product and in no case will TE Connectivity be liable for any incidental, indirect or consequential damages arising out of the sale, resale, use or misuse of the product. Users of TE Connectivity products should make their own evaluation to determine the suitability of each such product for the specific application.

© 2015 TE Connectivity Ltd. family of companies All Rights Reserved.

## Данный компонент на территории Российской Федерации

### Вы можете приобрести в компании MosChip.

Для оперативного оформления запроса Вам необходимо перейти по данной ссылке:

<http://moschip.ru/get-element>

Вы можете разместить у нас заказ для любого Вашего проекта, будь то серийное производство или разработка единичного прибора.

В нашем ассортименте представлены ведущие мировые производители активных и пассивных электронных компонентов.

Нашей специализацией является поставка электронной компонентной базы двойного назначения, продукции таких производителей как XILINX, Intel (ex.ALTERA), Vicor, Microchip, Texas Instruments, Analog Devices, Mini-Circuits, Amphenol, Glenair.

Сотрудничество с глобальными дистрибьюторами электронных компонентов, предоставляет возможность заказывать и получать с международных складов практически любой перечень компонентов в оптимальные для Вас сроки.

На всех этапах разработки и производства наши партнеры могут получить квалифицированную поддержку опытных инженеров.

Система менеджмента качества компании отвечает требованиям в соответствии с ГОСТ Р ИСО 9001, ГОСТ РВ 0015-002 и ЭС РД 009

### Офис по работе с юридическими лицами:

105318, г.Москва, ул.Щербаковская д.3, офис 1107, 1118, ДЦ «Щербаковский»

Телефон: +7 495 668-12-70 (многоканальный)

Факс: +7 495 668-12-70 (доб.304)

E-mail: [info@moschip.ru](mailto:info@moschip.ru)

Skype отдела продаж:

moschip.ru

moschip.ru\_4

moschip.ru\_6

moschip.ru\_9