



INNOVATION SERIES

Linear LED Light Modules



Overview

Heatron's Innovation Series LED Modules provide luminaire manufacturers with the key components needed to move LED lighting projects from concept to production. The LED modules were built for design engineers looking for an easy way to prototype new fixture designs. An off-the-shelf platform, these modules move seamlessly from prototype to final design. Innovation Modules are centered on Cree XPG and XTE LEDs. Custom configurations are available for OEM's who prefer other LED packages, flux bins, color temperatures or CRI.

Linear Innovation Series LED Modules are available in three sizes with two, three, or six LED arrays.

Also see our Round Innovation Series LED Modules, available in three versions with three or seven LED arrays.

Innovation Series modules come with easy-to-use connectors, enabling quick prototyping of various light engines.



*Transforming Your Vision
into Higher Performance Solutions*

Linear LED Light Modules

Key Features

- Luminous efficacy of up to 78 lm/W
- Available in 3000 K
- CRI 80
- Peel and stick thermal interface for easy integration into OEM light fixtures
- Environmentally green: Mercury and UV Free
- 5 year warranty

Fixture Types

- Sconce
- Linear
- Accent
- Step
- Cove
- Under cabinet task

Optical Characteristics T_j = 85°C

Part Number	Lumen ⁽¹⁾ Values If @ 700 mA	Lumen ⁽¹⁾ Values If @1.5A	Color Temperature (Kelvin)	CRI Minimum
JDHT-LMC02-XPG-WW-094	300	530	3000	80
JDHT-LMC03-XPG-WW-094	450	810	3000	80
JDHT-LMC06-XPG-WW-094	900	1600	3000	80
JDHT-LMC02-XTE-WW-094	320	550	3000	80
JDHT-LMC03-XTE-WW-094	500	860	3000	80
JDHT-LMC06-XTE-WW-094	1000	1700	3000	80

¹Values are nominal. Flux values measured without optics.

Electrical Characteristics T_j = 85°C

Part Number	V _f		Forward Current		Input Power	
	Nominal	Max	Nominal	Max	Nominal	Max
JDHT-LMC02-XPG-WW-094	5.8 V	6.2 V	700 mA	1.5 A	4.0 W	9.2 W
JDHT-LMC03-XPG-WW-094	8.65 V	9.24 V	700 mA	1.5 A	6.0 W	13.9 W
JDHT-LMC06-XPG-WW-094	17.3 V	18.5 V	700 mA	1.5 A	12.1 W	27.7 W
JDHT-LMC02-XTE-WW-094	6.1 V	6.8 V	700 mA	1.5 A	4.3 W	10.1 W
JDHT-LMC03-XTE-WW-094	9.14 V	10.12 V	700 mA	1.5 A	6.4 W	15.2 W
JDHT-LMC06-XTE-WW-094	18.3 V	20.3 V	700 mA	1.5 A	12.8 W	30.4 W

Ordering Information

Example: JDHT-LMC02-XPG-WW-094

Internal	Series	LED Quantity	LED	Color Temperature	Min. Flux Bin	Optics C_B
JDHT	LMC	02 03 06	XTE XPG	WW = 3000	094	Blank = no optics N = Narrow 10° M = Medium 30° W = Wide 40°

Contact Heatron LED Integration for alternative Innovations Series product configurations in LEDs, flux, CCT and CRI

Linear LED Light Modules

Linear 2 LED Array

Linear 3 LED Array

Linear 6 LED Array



Dimensions

All Linear LED Array Dimensions: Width & Height

Linear 2 LED Array Dimensions: Length & Positioning

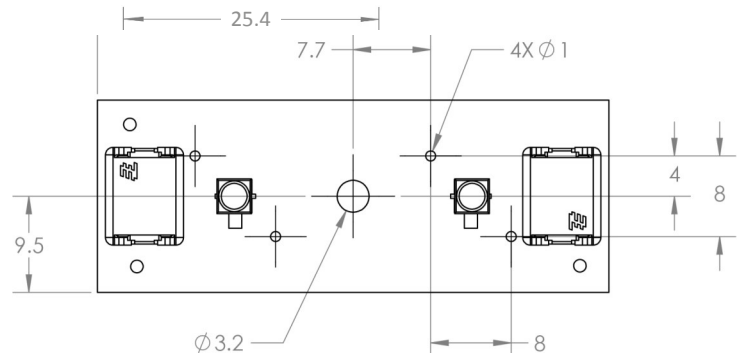
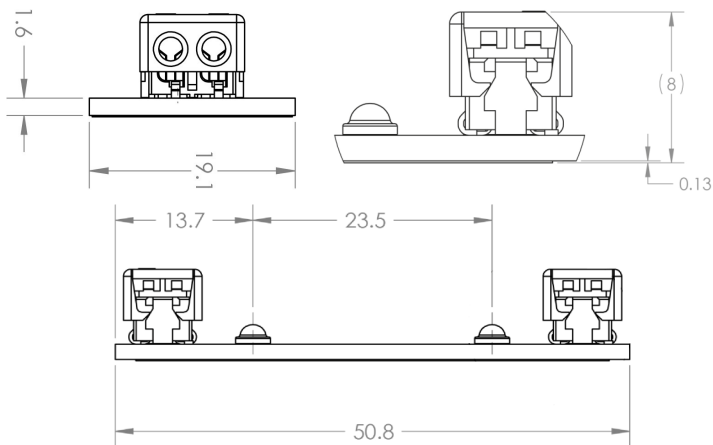

Dimensions

Linear 3 LED Array Dimensions: Length & Positioning

Linear 6 LED Array Dimensions: Length & Positioning

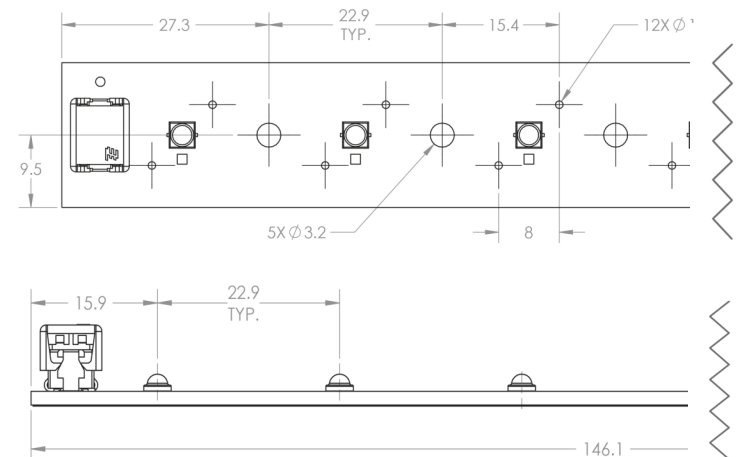
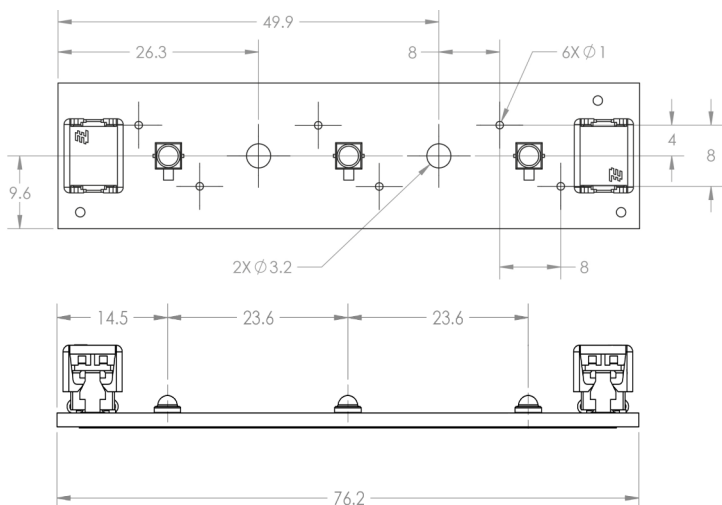

All dimensions are in millimeters.

Innovation Series LED Modules are high output arrays; use with constant current driver and heat sink capable of dissipating 10 Watts for Linear 2 LED Arrays, 15 Watts for Linear 3 LED Array and 30 Watts for Linear 6 LED Array. Contact Heatron for list of compatible LED drivers.



About Heatron LED Integration

Heatron LED Integration helps OEMs reduce costs, speed time to market and ensure superior quality and performance. Heatron LED Integration leverages the engineering disciplines of optical, electrical and mechanical design, with expertise in thermal management.

Offering various levels of integration ranging from design and manufacture of component level LED light engines to turnkey lighting solutions, Heatron designs for a broad range of uses, including indoor, outdoor, commercial, industrial, healthcare and transportation lighting applications.

Heatron, Inc. – *Transforming Your Vision into Higher Performance Solutions.*
For more information about Heatron LED Integration, its products, services and manufacturing, visit www.heatron.com

3000 Wilson Avenue
Leavenworth, KS 66048-4637 USA
877.553.9070

P: 1.913.651.4420 • F: 1.913.651.5352
www.heatron.com • heatron1@heatron.com
ISO 9001 • Registered by Underwriters Laboratories, Inc.



Данный компонент на территории Российской Федерации

Вы можете приобрести в компании MosChip.

Для оперативного оформления запроса Вам необходимо перейти по данной ссылке:

<http://moschip.ru/get-element>

Вы можете разместить у нас заказ для любого Вашего проекта, будь то серийное производство или разработка единичного прибора.

В нашем ассортименте представлены ведущие мировые производители активных и пассивных электронных компонентов.

Нашей специализацией является поставка электронной компонентной базы двойного назначения, продукции таких производителей как XILINX, Intel (ex.ALTERA), Vicor, Microchip, Texas Instruments, Analog Devices, Mini-Circuits, Amphenol, Glenair.

Сотрудничество с глобальными дистрибьюторами электронных компонентов, предоставляет возможность заказывать и получать с международных складов практически любой перечень компонентов в оптимальные для Вас сроки.

На всех этапах разработки и производства наши партнеры могут получить квалифицированную поддержку опытных инженеров.

Система менеджмента качества компании отвечает требованиям в соответствии с ГОСТ Р ИСО 9001, ГОСТ РВ 0015-002 и ЭС РД 009

Офис по работе с юридическими лицами:

105318, г.Москва, ул.Щербаковская д.3, офис 1107, 1118, ДЦ «Щербаковский»

Телефон: +7 495 668-12-70 (многоканальный)

Факс: +7 495 668-12-70 (доб.304)

E-mail: info@moschip.ru

Skype отдела продаж:

moschip.ru

moschip.ru_4

moschip.ru_6

moschip.ru_9