

PSI-MOS-RS485W2/FO...

Fiber optic converter for RS-485 2-wire bus systems



INTERFACE

Data sheet
101973_en_04

© PHOENIX CONTACT 2010-01-08

1 Description

PSI-MOS-RS485W2/FO... devices can be used to convert RS-485 2-wire bus systems to fiber optics.

All bus systems with 10/11-bit UART data format and NRZ data encoding are supported. This includes popular bus systems such as:

- Modbus ASCII/Modbus RTU
- SUCONET K
- S-BUS
- DH-485
- Various other company-specific bus systems

A transparent protocol is used to convert all common transmission speeds up to a maximum of 500 kbps. The integrated optical diagnostics enable fiber optic paths to be monitored continuously during installation and even during operation. The floating switch contact is activated when the signal output on the fiber optic paths drops to a critical level. This early alarm generation enables critical system states to be diagnosed before they result in failure.

PSI-MOS-RS485W2/FO... E termination devices convert an RS-485 interface to a fiber optic cable. They are ideal for point-to-point connections.

PSI-MOS-RS485W2/FO... T fiber optic T-couplers convert to two fiber optic cables.

Virtually any cascadable star and tree structures can be created using integrated bit retiming, even in a redundant version if required. In this case, the required devices are snapped onto DIN rail connectors, which ensure that the supply voltage and data signals are routed through.

Devices with different transmission technologies (polymer, HCS, and glass fiber) can be freely combined within a star coupler.

PSI-MOS-RS485W2/FO 660... devices are networked using polymer fiber cable for distances up to 100 m and HCS fiber cable for up to 800 m. They are connected via F-SMA quick mounting connectors, which can be assembled locally within a few minutes.

PSI-MOS-RS485W2/FO 850 ... devices are available for longer paths and can be used for distances up to 2800 m using HCS fiber cable and B-FOC (ST[®]) fast connection technology and up to 4200 m using multi-mode glass fiber cable.

The PSI-MOS system can be used with input voltages from 18 V DC to 32 V DC and in a temperature range from -20°C to +60°C.



If you have any technical problems, which you cannot resolve with the aid of this documentation, please contact us during the usual office hours at:

Phone: +49 - 52 35 - 31 98 90

Fax: +49 - 52 35 - 33 09 99

E-mail: interface-service@phoenixcontact.com



Make sure you always use the latest documentation.

It can be downloaded at www.phoenixcontact.net/catalog.



This data sheet is valid for all products listed on the following page:

Table of contents

1	Description.....	1
2	Ordering data.....	3
3	Technical data	4
4	Safety regulations and installation notes.....	7
	4.1 Installation and operation	7
	4.2 Installation in zone 2	7
5	Supported network structures.....	8
	5.1 Point-to-point connections.....	8
	5.2 Linear structures.....	8
	5.3 Star structures	8
	5.4 Tree structures	9
6	Function elements	9
7	Definition of fiber optic diagnostics	10
8	Configuration	11
	8.1 Setting the transmission speed	11
	8.2 10/11-bit selection (DIP 5).....	11
	8.3 Connection to fiber optic interfaces from third-party suppliers (DIP 6/7).....	12
	8.4 Activating the redundancy function (DIP 8).....	12
	8.5 Disabling the second fiber optic port (DIP 9)	12
	8.6 Switch with no function (DIP 10).....	12
	8.7 Mixed operation of PSI-MOS and PSM-EG.....	12
9	Connection notes	13
	9.1 Combined assembly with a system power supply unit (modular star coupler).....	13
	9.2 Assembly as an individual device in the control cabinet (stand-alone).....	14
	9.3 Assembly in potentially explosive areas	14
	9.4 Removal.....	14
10	Cabling notes.....	15
	10.1 Connecting the supply voltage	15
	10.2 Connecting the data cables/bus termination.....	15
	10.3 Wiring the switch contact.....	16
	10.4 Connecting the fiber optic cables	17
11	Signal delay	18

2 Ordering data

Fiber optic converters

Description	Type	Order No.	Pcs./Pkt.
Termination device with one fiber optic interface			
Fiber optic converter with integrated optical diagnostics, alarm contact, for RS-485 2-wire bus systems (SUCONET K, Modbus, etc.) up to 500 kbps, NRZ encoding			
660 nm, for polymer/HCS fiber cable, F-SMA	PSI-MOS-RS485W2/FO 660 E	2708313	1
850 nm, for HCS/glass fiber cable, B-FOC (ST®)	PSI-MOS-RS485W2/FO 850 E	2708339	1
T-coupler with two fiber optic interfaces			
Fiber optic converter with integrated optical diagnostics, alarm contact, for RS-485 2-wire bus systems (SUCONET K, Modbus, etc.) up to 500 kbps, NRZ encoding			
660 nm, for polymer/HCS fiber cable, F-SMA	PSI-MOS-RS485W2/FO 660 T	2708300	1
850 nm, for HCS/glass fiber cable, B-FOC (ST®)	PSI-MOS-RS485W2/FO 850 T	2708326	1

Accessories

Description	Type	Order No.	Pcs./Pkt.
System power supply unit for supplying a modular star coupler topology	MINI-SYS-PS 100-240AC/24DC/1.5	2866983	1
System power supply unit for supplying a modular star coupler topology, for potentially explosive areas	MINI-PS-100-240AC/24DC/1.5/EX	2866653	1
End clamps	CLIPFIX 35	3022218	50
DIN rail connector, power supply and data (2 per device)	ME 17,5 TBUS1,5/5-ST-3,81GN	2709561	10
DIN rail connector, power supply only (2 per device)	ME 17,5 TBUS1,5/PP000-3,81BK	2890014	10
Polymer fiber connectors (4 connectors in the set)	PSM-SET-FSMA/4-KT	2799720	1
Polishing set for polymer fiber connectors (required to assemble polymer fiber connectors)	PSM-SET-FSMA-POLISH	2799348	1
Fiber optic polymer fiber cable for indoor installation	PSM-LWL-KDHEAVY	2744319	1
F-SMA HCS fiber connectors (4 connectors in the set)	PSM-SET-FSMA/4-HCS	2799487	1
B-FOC (ST®) HCS fiber connectors (4 connectors in the set)	PSM-SET-B-FOC/4-HCS	2708481	1
Tool set for HCS connectors (F-SMA) (required for HCS connector assembly)	PSM-HCS-KONFTOOL	2799526	1
Tool set for HCS connectors (B-FOC (ST®)) (required for HCS connector assembly)	PSM-HCS-KONFTOOL/B-FOC	2708465	1
Fiber optic HCS cable for indoor installation	PSM-LWL-HCS RUGGED-200/230	2799885	1
Fiber optic HCS cable for outdoor installation	PSM-LWL-HCSO-200/230	2799445	1
Fiber optic glass fiber cable for indoor installation	PSM-LWL-GDM-RUGGED-50/125	2799322	1
Fiber optic glass fiber cable for outdoor installation	PSM-LWL-GDO-50/125	2799432	1
Measuring device for fiber optic power measurement	PSM-FO-POWERMETER	2799539	1

Other fiber optic converters in the PSI-MOS system

The PSI-MOS-RS485W2/FO 1300 E is networked for distances up to 25 km using multi-mode glass fiber cable and up to 45 km using single mode glass fiber cable.

Other fiber optic converters

Description	Type	Order No.	Pcs./Pkt.
Fiber optic converter with integrated optical diagnostics, alarm contact, for RS-485 2-wire bus systems (SUCONET K, Modbus, etc.) up to 500 kbps, NRZ encoding, termination device with one fiber optic interface (SC duplex), 1300 nm, for glass fiber cable	PSI-MOS-RS485W2/FO 1300 E	2708562	1

3 Technical data

Interfaces				
Power supply	24 V DC (18 V DC ... 32 V DC)			
Nominal current consumption	130 mA, maximum			
Ready-to-operate indicator	"VCC" LED (green)			
Maximum star coupler expansion	10			
Serial RS-485 interface				
Operating mode	Half duplex			
Bus termination resistor	220 Ω (can be connected to 390 Ω pull-up/pull-down)			
Data format/encoding	UART (10/11-bit selection, NRZ)			
Data direction changeover	Automatic control			
Transmission speed (set via DIP switches)	4.8/9.6/19.2/38.4/57.6/75/93.75/115.2/136/187.5/375/500 kbps			
Transmission length	Up to 1200 m, maximum depending on the transmission speed, with shielded, twisted pair data cable			
Connection	COMBICON plug-in screw terminal block			
Optical interface				
Transmission protocol	Transparent protocol to RS-485 interface			
Connection method	F-SMA	B-FOC (ST®)		
Wavelength	660 nm	850 nm		
Minimum transmission power (fiber type)	-5.3 dBm (980/1000 μm)	-4.0 dBm (200/230 μm)		
	-16.0 dBm (200/230 μm)	-17.6 dBm (50/125 μm)		
		-14.6 dBm (62.5/125 μm)		
Receiver sensitivity				
	Minimum	-30.1 dBm	-32.5 dBm (50/125 μm/62.5/125 μm)	
Maximum	-3.0 dBm (980/1000 μm)	-32.1 dBm (200/230 μm)		
Minimum transmission length including 3 dB system reserve	100 m with F-P 980/1000; 230 dB/km	4200 m with F-G 50/125; 2.5 dB/km		
	800 m with F-K 200/230; 10 dB/km with quick mounting connectors	4200 m with F-G 62.5/125; 3.0 dB/km		
Minimum transmission length	2800 m with F-K 200/230; 8.0 dB/km			
1 m with F-K 200/230; 8.0 dB/km				
General data				
Bit distortion input	±35%, maximum			
Bit distortion output	< 6.25%			
Bit delay	< 1 bit			
Electrical isolation	RS-485//power supply			
Test voltage	1.5 kV _{rms} , 50 Hz, 1 min.			
Alarm output	60 V DC/42 V AC, 1 A, maximum			
Status and diagnostic indicators	Power supply (VCC), transmit/receive data RS-485, fiber optic bar graph (FO SIGNAL), fiber optic error (FO ERR)			
Housing material	PA V0, green			
Ambient temperature				
Operation	-20°C ... +60°C			
Storage/transport	-40°C ... +85°C			
Humidity	30% ... 95%, no condensation			
Dimensions (W x H x D)	35 mm x 99 mm x 105 mm			
Degree of protection	IP20			
Weight	190 g, approximately			
MTBF according to Telcordia standard	Termination devices (E)		T-couplers (T)	
	660 nm	850 nm	660 nm	850 nm
Ambient temperature 25°C	358 years	272 years	220 years	159 years
Ambient temperature 40°C	73 years	44 years	44 years	24 years

General data (continued)

Chloroform test	Free from substances that would hinder coating with paint or varnish (according to VW/Audi/Seat specification)
Vibration resistance	5g according to IEC 60068-2-6, 2.5 h each in x, y, and z direction, criterion A
Shock resistance	15g according to IEC 60068-2-27 with 11 ms pulse length, criterion C
Free fall	1 m without packaging according to IEC 60950
Air and creepage distances	DIN EN 60664-1/VDE 0110-1, DIN EN 50178, DIN EN 60950

Tests/approvals

CE



UL/CUL 1604 Ex listed



PROCESS CONTROL EQUIPMENT FOR HAZARDOUS LOCATIONS
31ZN



Ex

Fiber optic interface
Device

Conformance with EMC Directive 2004/108/EC and Low Voltage Directive 2006/95/EC**Noise immunity test according to EN 61000-6-2¹**

Electrostatic discharge (ESD)	EN 61000-4-2	Criterion B ²	
Air discharge			8 kV
Contact discharge			6 kV
Electromagnetic HF field	EN 61000-4-3	Criterion A ³	
Amplitude modulation			10 V/m
Fast transients (burst)	EN 61000-4-4	Criterion B ²	
Signal			2 kV/5 kHz
Power supply			2 kV/5 kHz
Surge current load (surge)	EN 61000-4-5	Criterion B ²	
Signal			1 kV/42 Ω
Power supply			0.5 kV/2 Ω
Conducted interference	EN 61000-4-6	Criterion A ³	10 V

Noise emission test according to EN 61000-6-4

Noise emission of housing	EN 55011 ⁴	Class A ⁵
---------------------------	-----------------------	----------------------

¹ EN 61000 corresponds to IEC 61000

² Criterion B: Temporary adverse effects on the operating behavior, which the device corrects automatically.

³ Criterion A: Normal operating behavior within the specified limits.

⁴ EN 55011 corresponds to CISPR11

⁵ Class A: Industrial application, without special installation measures.

Block diagram

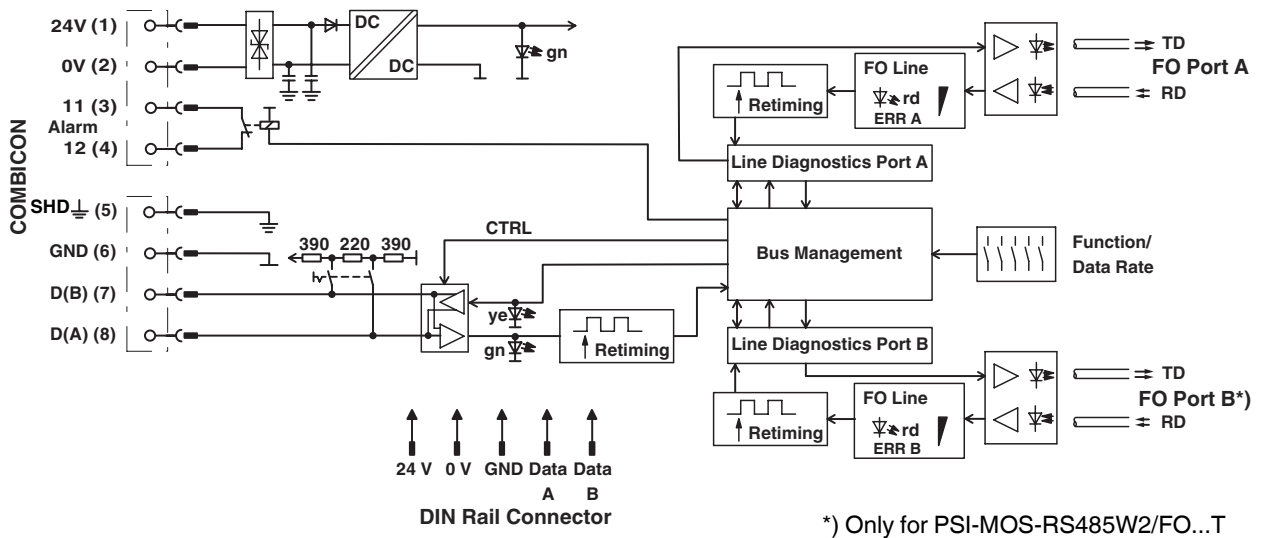

Figure 1 Block diagram

Housing dimensions

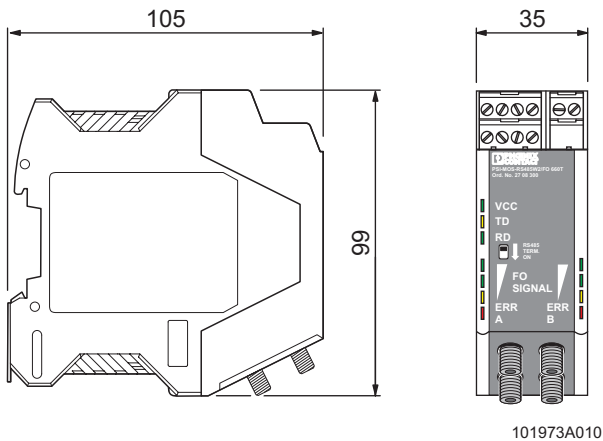

Figure 2 Housing dimensions (in mm)

4 Safety regulations and installation notes

4.1 Installation and operation

Follow the installation instructions.



NOTE: Installation, operation, and maintenance may only be carried out by qualified specialist personnel.

When installing and operating the device, the applicable safety directives (including national safety directives), accident prevention regulations, as well as general technical regulations, must be observed.



NOTE: The device must not be opened or modified apart from the configuration of the DIP switches.



NOTE: The switches that can be accessed may only be actuated when the power supply to the device is disconnected.

Do not repair the device yourself, replace it with an equivalent device. Repairs may only be carried out by the manufacturer.



NOTE: The IP20 degree of protection (IEC 60529/EN 60529) of the device is intended for use in a clean and dry environment. The device must not be subject to mechanical strain and/or thermal loads, which exceed the limits described.

For the safety data, please refer to the operating instructions and certificates (EC-type examination certificate, other approvals, if necessary).

4.2 Installation in zone 2



WARNING: Explosion hazard

The device is designed for installation in zone 2 potentially explosive areas.

Observe the specified conditions for use in potentially explosive areas.



WARNING: Explosion hazard

Install the device in suitable **housing with IP54 protection, minimum**, that meets the requirements of EN 60079-15.

Observe the requirements of EN 60079-14.



WARNING: Explosion hazard

Disconnect the block power supply **before**:

- Snapping it on or disconnecting it.
- Connecting or disconnecting cables.



WARNING: Explosion hazard

Only devices which are designed for operation in zone 2 potentially explosive areas and are suitable for the conditions at the installation location may be connected to the supply and signal circuits in zone 2.



WARNING: Explosion hazard

The device must be stopped and immediately removed from the Ex area if it is damaged or was subject to an impermissible load or stored incorrectly or if it malfunctions.

Installation in areas with a danger of dust explosions



WARNING: Explosion hazard

The device is **not** designed for installation in areas with a danger of dust explosions.

If dust is present, install the device in suitable, approved housing.

5 Supported network structures

The PSI-MOS-RS485W2/FO... system can be used to create network topologies that are ideally adapted to the relevant application. The structures are described briefly below.

5.1 Point-to-point connections

Two PSI-MOS-RS485W2/FO... E fiber optic termination devices can be used to easily convert a data link from copper cable to fiber optics.

If necessary, the point-to-point connection can also be designed redundantly to increase availability using PSI-MOS-RS485W2/FO... T T-couplers.

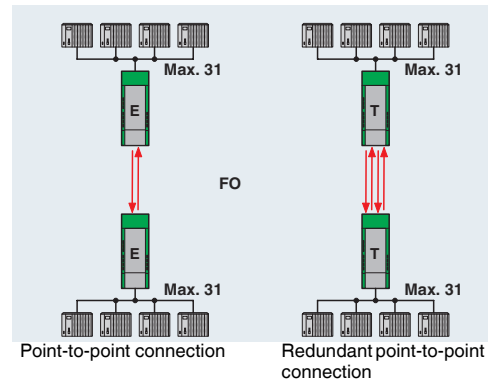

5.2 Linear structures

PSI-MOS-RS485W2/FO... devices can be used to network several RS-485 devices to form a linear structure.

PSI-MOS-RS485W2/FO... E termination devices are used at the beginning and end of the fiber optic line.

PSI-MOS-RS485W2/FO... T T-couplers with two fiber optic ports are used along the line.

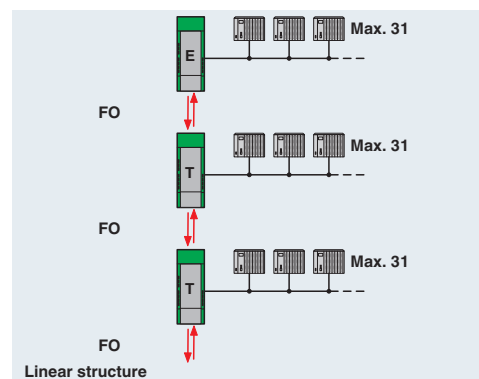

5.3 Star structures

RS-485 devices can also be networked in a star structure. Depending on the number of star lines required, several T-couplers or termination devices are connected to an active star coupler.

Up to ten PSI-MOS-RS485W2/FO... devices can be connected to each star coupler. Cross-wiring for RS-485 data and for the supply voltage is provided automatically by the DIN rail connector (installation accessory, see page 3).

If increased availability is required, redundant star distributors can also be created using PSI-MOS-RS485W2/FO... T T-couplers.

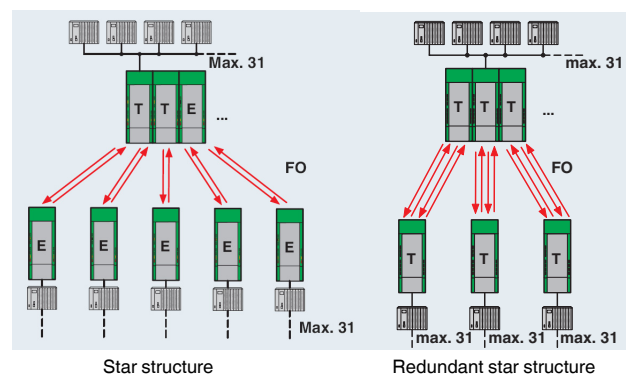

5.4 Tree structures

Linear and star structures can be cascaded to create complex tree structures, even in a redundant version if required.

The number of devices that can be cascaded is only limited by the timing response (timeout) of the bus system used due to the bit retiming of the PSI-MOS-RS485W2/FO... fiber optic converter.

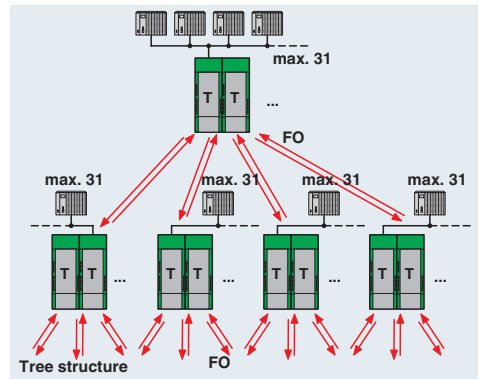

6 Function elements

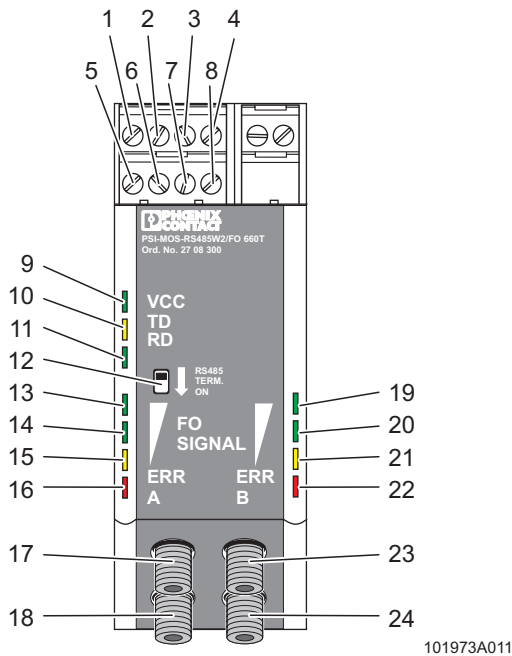

Figure 3 Function elements

- 1 24 V DC supply voltage connection
- 2 0 V DC supply voltage connection
- 3 Switch contact, connection 11
- 4 Switch contact, connection 12
- 5 SHD, shield
- 6 GND, ground
- 7 D (B), transmit/receive positive
- 8 D (A), transmit/receive negative
- 9 "VCC" LED

- 10 "TD" LED
- 11 "RD" LED
- 12 Bus termination ON/OFF
- 13 "FO SIGNAL" LED (port A)
- 14 "FO SIGNAL" LED (port A)
- 15 "FO SIGNAL" LED (port A)
- 16 "ERR" LED (port A)
- 17 Fiber optic transmitter (port A)
- 18 Fiber optic receiver (port A)
- 19 "FO SIGNAL" LED (port B)¹
- 20 "FO SIGNAL" LED (port B)¹
- 21 "FO SIGNAL" LED (port B)¹
- 22 "ERR" LED (port B)¹
- 23 Fiber optic transmitter (port B)¹
- 24 Fiber optic receiver (port B)¹

Diagnostic and status indicators

Des.	Color	Meaning	
VCC	Green	Ready-to-operate	
TD	Yellow	Sending data at the RS-485 copper interface	
RD	Green	Receiving data at the RS-485 copper interface	
FO SIGNAL	Green	Receiving power at fiber optic port A/B (see page 10)	Very good
	Green		Good
	Yellow		Critical
ERR	Red	Insufficient, broken fiber	

¹ Only for PSI-MOS-RS485W2/FO... T

7 Definition of fiber optic diagnostics

The quality of the path is determined using the incoming optical power P_{opt} and displayed using the LED bar graph. DIP 7 = "OFF" is used to switch the transmitters in the idle state (rest period between transmitting data) to steady light (INVERS), to enable continuous fiber optic diagnostics.

LED bar graph	Receive status	Optical power P_{opt}
Green Green Yellow	Very good	P_{opt} is considerably greater than the system reserve
Green Yellow	Good	P_{opt} is still greater than the system reserve
Yellow	Critical	P_{opt} has reached the system reserve
Red	Error	P_{opt} has sapped the system reserve/broken fiber

As soon as the system reserve is reached, only the yellow LED remains lit. At the same time, the signaling relay drops and the switch contact opens. Data communication is still possible.

In "Redundant ring" mode, the affected fiber optic port is already switched off when the LED goes to yellow.

Echo evaluation

If DIP 7 is set to "ON" (NORM), the echo evaluation (DIP 6 = "OFF") is available as diagnostics (see "Connection to fiber optic interfaces from third-party suppliers (DIP 6/7)" on page 12).

Echo evaluation is used to detect broken fibers for the devices. During the idle phase (rest period between transmitting data), the fiber optics between directly connected devices are monitored for broken fibers.

In the event of a broken fiber, the affected optical fiber is switched off, the error LED is set (16 in Figure 3 on page 9), and the switching output is activated.

If the default setting for DIP 7 = "OFF" (INVERS) is used, echo evaluation is switched off because the built-in diagnostics (FO signal) permanently evaluates the received signal and therefore also detects a broken fiber.

If echo evaluation is also switched off (DIP 6 = "ON"), fiber optic diagnostics are not available.

DIP 6	DIP 7	Meaning
Not relevant	OFF ("INVERS")	Continuous fiber optic diagnostics, broken fiber detection disabled
OFF	ON (NORM)	Continuous fiber optic diagnostics, broken fiber detection active
ON (MIXED)	ON (NORM)	Continuous fiber optic diagnostics and broken fiber detection disabled. Diagnostics are no longer available.

Basic method of operation

The PSI-MOS device has a maximum of four interfaces for the RS-485 signal: the electrical interface (COMBICON), the two fiber optic ports (port B only for T-couplers), and the DIN rail connector.

All interfaces communicate with one another with equal rights. A signal available at one of the interfaces is also available at all other interfaces.

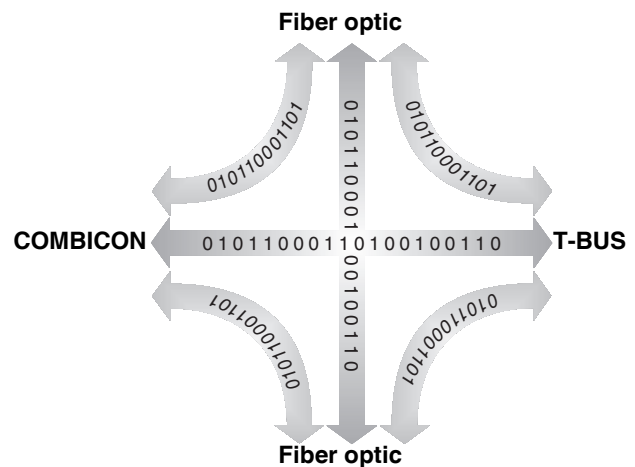

101972B012

Figure 4 Communication between the interfaces

8 Configuration



NOTE: Electrostatic discharge

The device contains components that can be damaged or destroyed by electrostatic discharge. When handling the device, observe the necessary safety precautions against electrostatic discharge (ESD) according to EN 61340-5-1.

- For configuration, release the housing cover using a screwdriver (A in Figure 5).
- Then carefully pull the PCB out of the housing as far as possible (B).

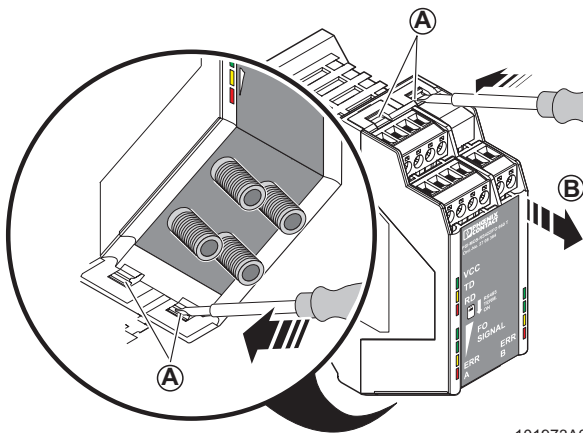

101973A001

Figure 5 Opening the housing

DIP switches 1 to 10 are then freely accessible.

- Configure the DIP switches according to the planned application.

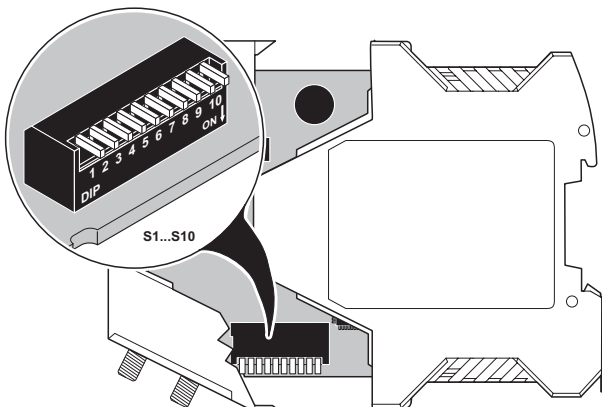

101973A002

Figure 6 Setting the DIP switches

The following tables provide an overview of the DIP switch functions. By default upon delivery, all DIP switches are in the "OFF" position.



NOTE: After changing the device settings, disconnect the power to the device so that the settings can be applied.

8.1 Setting the transmission speed

The transmission speed is set using DIP switches 1 to 4.



NOTE: Set all fiber optic converters and all connected RS-485 devices to the same transmission speed.

Transmission speed	DIP switch			
	1	2	3	4
500 kbps	OFF	OFF	OFF	OFF
375 kbps	OFF	OFF	OFF	ON
187.5 kbps	OFF	OFF	ON	OFF
136 kbps	OFF	OFF	ON	ON
115.2 kbps	OFF	ON	OFF	OFF
93.75 kbps	OFF	ON	OFF	ON
75 kbps	OFF	ON	ON	OFF
57.6 kbps	OFF	ON	ON	ON
38.4 kbps	ON	OFF	OFF	OFF
19.2 kbps	ON	OFF	OFF	ON
9.6 kbps	ON	OFF	ON	OFF
4.8 kbps	ON	OFF	ON	ON

DIP switch	ON	OFF
5	10 BIT	11 BIT
6	MIXED	-
7	NORM	INVERS
8 ¹	REDUNDANCY	-
9 ²	END	NEXT
10 ²	N.C.	

¹ No function for PSI-MOS-RS485W2/FO... E termination devices.

² Not available for PSI-MOS-RS485W2/FO... E termination devices.

8.2 10/11-bit selection (DIP 5)



Please always observe the UART character word length specified by the control system manufacturer.

The standard word length of a UART character is 11 bits. However, some bus systems, e.g., Modbus in ASCII mode, transmit 10-bit word lengths.

- Set DIP switch 5 to "ON" ("10 BIT") (default setting: "OFF").

If operating Modbus in RTU mode, leave DIP switch 5 set to "OFF" ("11 BIT").

When used with the Inline multiplexer system, select a word length of 11 bits and 75 kbps.

8.3 Connection to fiber optic interfaces from third-party suppliers (DIP 6/7)

During the idle phase, fiber optic interfaces return to an idle setting defined by the manufacturer. This idle setting may vary for different manufacturers and devices. As fiber optic interfaces can only be operated together if they have the same idle setting, this should be set using the DIP switches. For mixed operation of PSI-MOS with fiber optic interfaces from other manufacturers, proceed as follows.

- Deactivate echo evaluation.
Set DIP 6 to "ON".
- Check the idle setting for the third-party interface:
Logic 1 = Light off
Logic 1 = Light on
- If necessary, adjust the idle setting of PSI-MOS using DIP 7.

DIP 7	Idle setting	Meaning
OFF = INVERS	Light on ¹	Logic 1
ON = NORM	Light off	Logic 1

¹ Default setting



NOTE: If DIP 7 is set to "ON", fiber optic diagnostics are not available via the LED bar graph.

The LED bar graph can light up at high transmission speeds or flash at low transmission speeds. This display does **not** correspond to continuous evaluation of the optical power.



NOTE: When connecting third-party devices, observe the receiver sensitivity and overrange of the fiber optic interfaces.

8.4 Activating the redundancy function (DIP 8)

For increased availability, redundant fiber optic connections can be created using T-couplers. In this case, the redundancy function must be activated at the start and end of the redundant fiber optic connection.

- To do this, set DIP switch 8 (REDUNDANCY) to "ON".

When the redundancy function is enabled, data communication takes place via fiber optic port A by default. In the event that the signal level of the standard cable drops to a critical level, it automatically switches to port B.



NOTE: Always connect redundant fiber optic connections from fiber optic port A to port A of the opposite device or from port B to port B of the opposite device.

8.5 Disabling the second fiber optic port (DIP 9)

If the second fiber optic port (B) is not used for PSI-MOS-RS485W2/FO... T T-couplers, it must be disabled. Otherwise the red "ERR" LED will light up.

- Set DIP 9 to "ON" (END).

8.6 Switch with no function (DIP 10)

This switch has no function at present and is reserved for later function extensions.

8.7 Mixed operation of PSI-MOS and PSM-EG

Mixed operation of the old PSM-EG series with the new PSI-MOS series is generally possible. Please note the following settings and restrictions:

Device configuration

The DIP switch settings depend on the application requirements. Please note that the idle setting of all devices used in the entire system must be the same (can be set via DIP switches) and that the data rate set on all devices is the same.

Overload/underload capability of fiber optic interfaces

In rare cases (usually in the case of very short fiber optic connections of just a few meters), an overload of the PSI-MOS devices may occur in mixed operation. This is due to the highly sensitive PSI-MOS receivers, which cover large ranges but can be overloaded on short fiber optic paths.

In the event of an overload, a patch cable with fiber optic joint can be used to increase the attenuation of the path, which will ensure error-free operation.

In mixed operation, observe the following ranges:

Fiber	Wavelength	Maximum range
Glass 50/125	850 nm	1600 m
Glass 62.5/125	850 nm	2200 m
HCS	Not permissible for PSM-EG	
POF	660 nm	70 m

9 Connection notes



WARNING: Only mount and remove devices when the power supply is disconnected.



WARNING: PSI-MOS-... devices are designed for SELV operation according to IEC 60950/EN 60950/VDE 0805.

- Install the device on a 35 mm DIN rail according to DIN EN 60715.
To avoid contact resistance only use clean, corrosion-free DIN rails.
- End clamps can be mounted on both sides of the device to stop the devices from slipping on the DIN rail (for ordering data, see page 3).



WARNING: Connect the DIN rail to protective earth ground using a grounding terminal block. The devices are grounded when they are snapped onto the DIN rail (installation according to PELV).

This ensures that the shielding is effective. Connect protective earth ground with low impedance.

9.1 Combined assembly with a system power supply unit (modular star coupler)

- Connect together the required number of DIN rail connectors for the connection station. Two DIN rail connectors are required for each device (see A in Figure 7). A maximum of ten devices are permitted in a connection station.
- Push the connected DIN rail connectors onto the DIN rail (B and C).
- Place the device onto the DIN rail from above. The upper holding keyway of the device must be hooked onto the top edge of the DIN rail (see Figure 7). Make sure that it is aligned correctly with the DIN rail connectors.
- Once the device has been snapped on properly, check that it is fixed securely on the DIN rail.

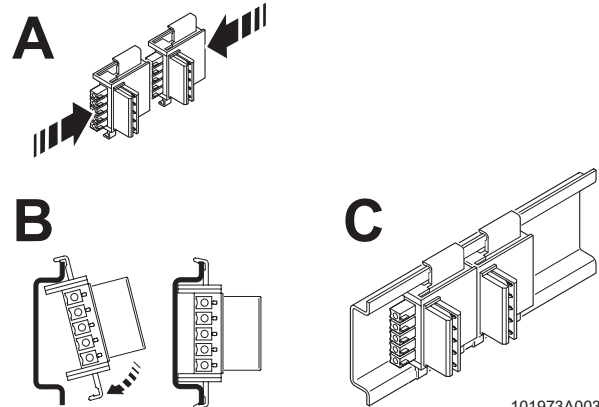

101973A003

Figure 7 Combined assembly

9.2 Assembly as an individual device in the control cabinet (stand-alone)

- Place the device onto the DIN rail from above. The upper holding keyway of the device must be hooked onto the top edge of the DIN rail (see Figure 8).
- Push the device from the front towards the mounting surface.
- Once the device has been snapped on properly, check that it is fixed securely on the DIN rail.

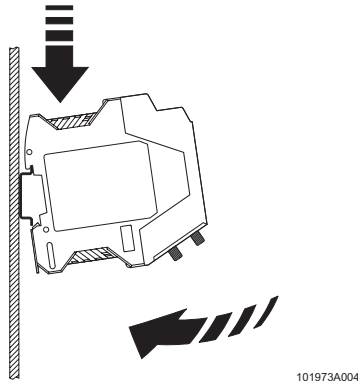

Figure 8 Assembly in the control cabinet

9.3 Assembly in potentially explosive areas



WARNING: Observe the safety notes on page 7.

- Areas with a danger of gas explosions
The devices are suitable for use in zone 2. Devices that are installed in zone 1 cannot be connected to the fiber optic interface. The fiber optic interface is an associated item of equipment with protection type "Ex op is".
- Areas with a danger of dust explosions
The device is **not** designed for installation in areas with a danger of dust explosions.
If dust is present, install the device in suitable, approved housing.
When installed outside areas with a danger of dust explosions, devices installed in zone 22 or 21 can also be connected to the fiber optic interface.

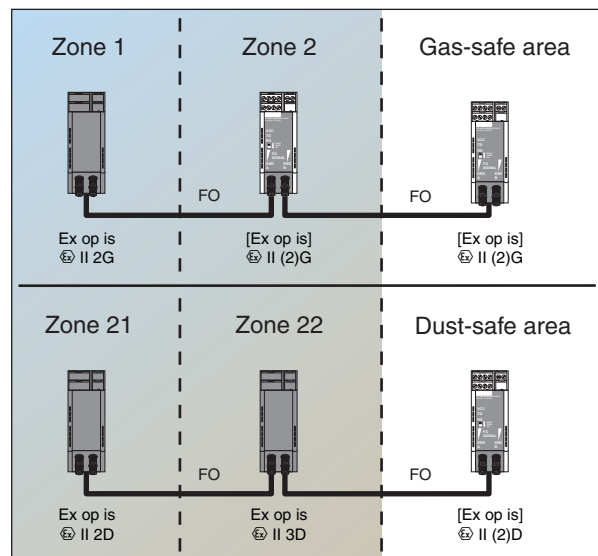

101973A013

9.4 Removal

- Pull the locking latch down using a screwdriver, needle-nose pliers or similar.
- Pull the bottom edge of the module away from the mounting surface.
- Pull the module diagonally upwards away from the DIN rail.
- If removing a complete star distributor, remove the DIN rail connectors from the DIN rail as well.

10 Cabling notes

10.1 Connecting the supply voltage



WARNING: The device is operated with a +24 V DC SELV.

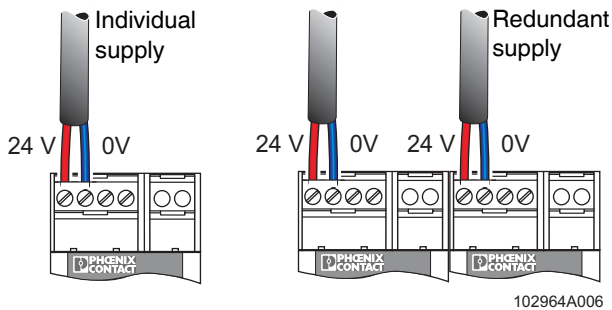

Figure 9 Individual/redundant supply

Operation as an individual device

Supply the supply voltage to the module via terminal blocks 1 (24 V) and 2 (0 V).

Operation in a star coupler topology

When the devices are operated in a star coupler topology, the supply voltage must only be supplied to the first device in the station. The remaining devices are supplied via the DIN rail connector. A redundant supply concept can be created by connecting a second power supply unit to another device in the topology.

Using the MINI POWER system power supply unit

As an alternative, the star coupler topology can also be supplied using the MINI-SYS-PS 100-240AC/24DC/1.5 (Order No. 2866983) or MINI-PS-100-240AC/24DC/1.5/EX (Order No. 2866653) system power supply unit. It is connected via two DIN rail connectors.

Usually the system power supply unit is mounted as the first device in a topology. A second power supply unit can be used to create a redundant supply concept.

10.2 Connecting the data cables/bus termination



NOTE: Use shielded twisted pair data cables. Connect the cable shielding at both ends of the transmission path.

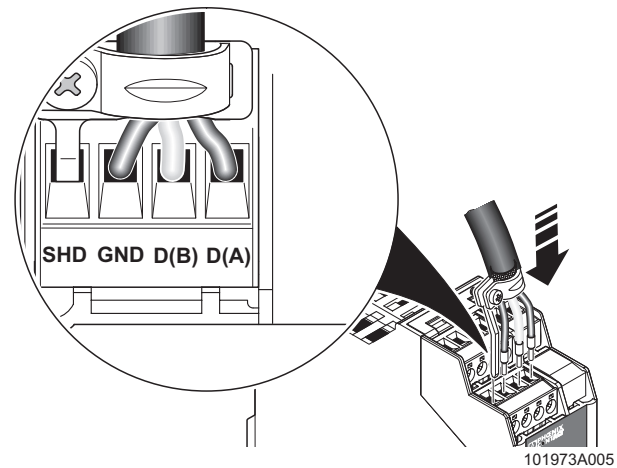

Figure 10 Connecting the data cables

- Connect the data cables and the data cable shield to the corresponding contacts on the COMBICON connector. For optimum shield connection use the terminal clamp provided.
- If the fiber optic converter is located at the start or end of an electrical RS-485 segment, activate termination on the top of the device (12 in Figure 3 on page 9).



NOTE: The maximum length of the RS-485 cables depends on the transmission speed. The values listed in the table must not be exceeded.

Transmission speed [kbps]	Maximum range [m]
≤ 93.75	1200
≤ 500	400

10.3 Wiring the switch contact

PSI-MOS-RS485W2/FO... converters are equipped with a floating switch contact for error diagnostics (connection terminal blocks 3 and 4 in Figure 3 on page 9). This contact opens on the affected device if:

- The supply voltage fails
- An interrupt is detected on the fiber optic path
- The system reserve for the fiber optic path is not reached

The switch contact is an N/C contact and can be connected to a local digital input, e.g., on the PLC, to support error detection.

When using a device topology (modular star coupler), the individual contacts can be connected to separate input points or the individual contacts can be looped to generate a group message (Figure 11).



NOTE: The maximum load capacity of the relay contact is 60 V DC/42 V AC, 1 A.

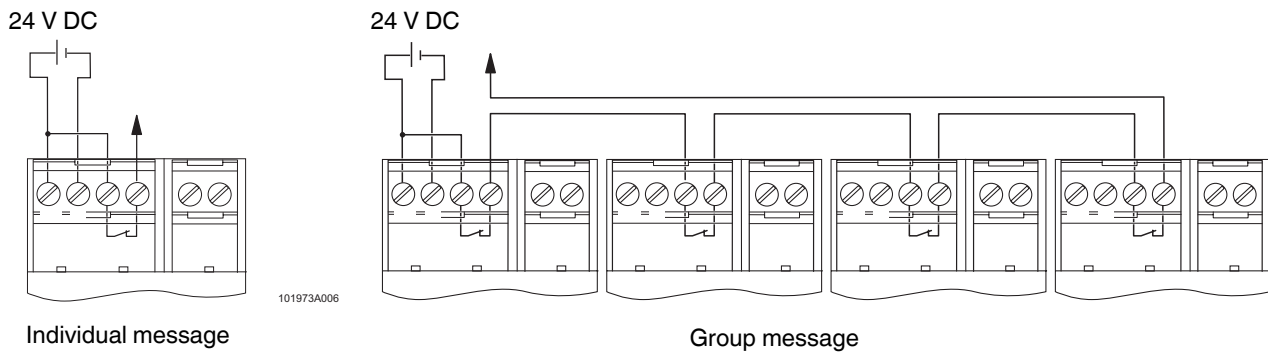

Figure 11 Individual and group message

10.4 Connecting the fiber optic cables



WARNING: Risk of eye injury
 During operation, do not look directly into transmitter diodes or use visual aids to look into the glass fibers.
 The infrared light is not visible.



NOTE: Dust protection caps should only be removed just before the connectors are connected. They prevent contamination of the transmit and receive elements.
 The same applies for the protective caps on the connectors.



NOTE: The following fiber optic lengths must not be exceeded:
PSI-MOS-RS485W2/FO 660 ...
 - 100 m with F-P 980/1000; 230 dB/km
 - 800 m with F-K 200/230; 10 dB/km
PSI-MOS-RS485W2/FO 850 ...
 - 2800 m with F-K 200/230; 8 dB/km
 - 4200 m with F-G 50/125; 2.5 dB/km
 - 4200 m with F-G 62.5/125; 3.0 dB/km



NOTE: When using fiber optics, observe the fiber optic installation guidelines, DB GB IBS SYS FOC ASSEMBLY (Order No. 9393909).

F-SMA connection (PSI-MOS-RS485W2/FO 660 ...)

PSI-MOS-RS485W2/FO 660 ... devices use F-SMA connectors for the fiber optic connection. F-SMA is a standardized fiber optic connection.

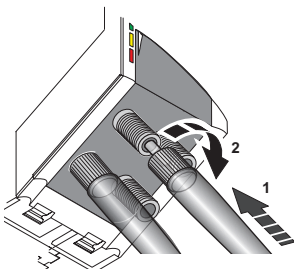

Figure 12 F-SMA connection

- The connectors are secured on the device by manually tightening the screw collar (see 2 in Figure 12).

B-FOC (ST®) connection (PSI-MOS-RS485W2/FO 850 ...)

Standardized B-FOC (ST®) connectors are used with PSI-MOS-RS485W2/FO 850 ... devices.

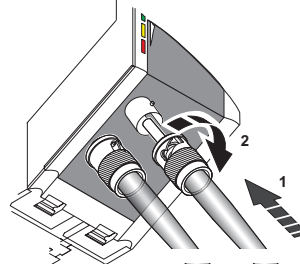

Figure 13 B-FOC connection

- Connect the fiber optic cable to the B-FOC (ST®) connector for the transmit and receive channel and push the connector clamp mechanism downwards.
- Secure the connection with a quarter turn to the right (see 2 in Figure 13).

Measuring and connecting devices

Due to the integrated optical diagnostics, there is no need to measure the path.



NOTE: Note the fiber optic cable signal direction when coupling two PSI-MOS devices:
 Device 1 fiber connection "TD" (transmitter) to device 2 fiber connection "RD" (receiver) (Figure 14).



NOTE: Due to different operating wavelengths, PSI-MOS-RS485W2/FO 660 ..., PSI-MOS-RS485W2/FO 850 ..., and PSI-MOS-RS485W2/FO 1300 E devices should not be connected directly with one another via fiber optic cables.

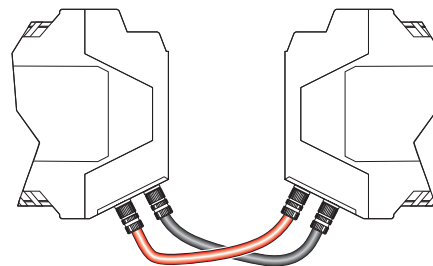

Figure 14 Crossed cables

11 Signal delay

Data transmission cables and network components lead to signal delays. This may also have to be taken into consideration when setting the timeout of the bus system used.

The signal delay **dT** can be calculated as follows:

$$dT = b \times L + 2 \times N$$

Where:

dT = Signal delay in bit periods for one complete signal cycle

b = Length parameter (see table)

L = Network expansion in km

N = Number of fiber optic converters

If necessary, adjust the timeout of your bus system to the signal delay.

Transmission speed [kbps]	Length parameter b
500	5.00
300	3.00
187.5	1.88
136	1.36
115.2	1.16
93.75	0.94
75	0.75
57.6	0.58
38.4	0.38
19.2	0.19
9.6	0.10
4.8	0.05

Данный компонент на территории Российской Федерации

Вы можете приобрести в компании MosChip.

Для оперативного оформления запроса Вам необходимо перейти по данной ссылке:

<http://moschip.ru/get-element>

Вы можете разместить у нас заказ для любого Вашего проекта, будь то серийное производство или разработка единичного прибора.

В нашем ассортименте представлены ведущие мировые производители активных и пассивных электронных компонентов.

Нашей специализацией является поставка электронной компонентной базы двойного назначения, продукции таких производителей как XILINX, Intel (ex.ALTERA), Vicor, Microchip, Texas Instruments, Analog Devices, Mini-Circuits, Amphenol, Glenair.

Сотрудничество с глобальными дистрибьюторами электронных компонентов, предоставляет возможность заказывать и получать с международных складов практически любой перечень компонентов в оптимальные для Вас сроки.

На всех этапах разработки и производства наши партнеры могут получить квалифицированную поддержку опытных инженеров.

Система менеджмента качества компании отвечает требованиям в соответствии с ГОСТ Р ИСО 9001, ГОСТ РВ 0015-002 и ЭС РД 009

Офис по работе с юридическими лицами:

105318, г.Москва, ул.Щербаковская д.3, офис 1107, 1118, ДЦ «Щербаковский»

Телефон: +7 495 668-12-70 (многоканальный)

Факс: +7 495 668-12-70 (доб.304)

E-mail: info@moschip.ru

Skype отдела продаж:

moschip.ru

moschip.ru_4

moschip.ru_6

moschip.ru_9