



ON Semiconductor®

<http://onsemi.com>

# LC89075WA

CMOS LSI

## Digital Audio Interface Receiver with Stereo ADC and Audio Selector

### 1. Overview

The LC89075WA is a digital audio interface receiver that demodulates signals according to the data transfer format between digital audio devices via IEC60958/61937 and JEITA CPR-1205 and supports demodulation sampling frequencies of up to 192kHz.

The LC89075WA also incorporates a high performance 24-bit single-end input  $\Delta\Sigma$  stereo analog to digital converter that supports sampling frequencies of up to 96kHz, and an audio selector that can support 8-channel data.

The LC89075WA is a complete analog and digital front-end for use in various systems including AV receivers, digital TVs, and DVD recorders.

### 2. Features

#### 2.1 ADC

- $\Delta\Sigma$  stereo ADC
- Built-in anti-aliasing digital filter
- Single-end input (3Vp-p)
- Built-in digital HPF for canceling DC offset
- Built-in PGA (-4.5dB to 6dB/1.5dB step)
- Built-in soft mute and attenuator (0dB to -63.5dB/0.25dB step,  $-\infty$ )
- Sampling frequency: 8kHz to 96kHz
- Master clock: 512fs, 256fs (master/slave)
- Audio data output interface: 24-bit I<sup>2</sup>S/left justified
- Analog audio data detection (threshold level: -30dB to -60dB/adjustable in 2dB steps)

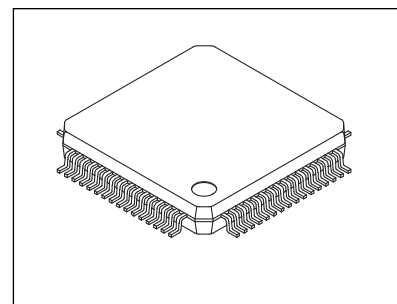

SQFP64(10X10)

#### 2.2 DIR

- S/PDIF demodulation process according to IEC60958/61937 and JEITA CPR-1205
- Reception frequency: 32kHz to 192kHz (PLL lock range)
- Built-in 15:3 digital data selector enables separate selection of data to be demodulated and data output to pins.
  - S/PDIF input: Up to 15 systems that support TTL (3 systems can support coaxial)
  - S/PDIF output: Possible to select two systems of pin outputs, and one system of demodulation data
- Possible to limit the acceptable sampling frequency and set the no-signal input status when the reception range is exceeded.
- Built-in a PLL low clock jitter and an oscillation amplifier.
- Outputs the monitor signal that is switched between PLL and crystal.
- Outputs master clock: 512fs, 256fs and 128fs (with automatic adjustment function)
- Audio data output interface: 24-bit I<sup>2</sup>S/left justified
- Outputs DTS-CD detection flag.
- Outputs interrupt signal for microcontroller.
- Calculates input sampling frequency.
- Reads IEC61937 burst preamble PC data from microcontroller.
- Reads first 40 bits of channel status from microcontroller.
- Outputs bit 1 (non-PCM data delimiter bit) and main bits of channel status to the pin.

### ORDERING INFORMATION

See detailed ordering and shipping information on page 70 of this data sheet.

## 2.3 Other

- Built-in audio selector supports up to 8-channel data.
  - Selector configuration to support 2-ch data: 4-line input ×6 and 4-line output ×2
  - Selector configuration to support 6-ch and 2-ch data: 6-line input ×1, 4-line input ×5 and 6-line output ×1
  - Selector configuration to support 8-ch and 2-ch data: 7-line input ×1, 4-line input ×4 and 7-line output ×1
- Possible to take in external error flag, non-PCM flag, and mute flag
- PCM digital audio data detection (threshold level: -30dB to -60dB/adjustable in 2dB steps)
- SPI microcontroller interface (with automatic increment function)
- Built-in power-on reset circuit
- Input pin reverse bias control during power-off
- Supply voltages:
  - ADC analog: 4.5 to 5.5V (3.0 to 3.6V possible when not using the ADC)
  - PLL analog: 3.0 to 3.6V
  - Digital: 3.0 to 3.6V
- Operation guarantee temperature: -30 to 85°C
- Package: SQFP64 (lead-free and halogen-free)

## Package Dimensions

unit : mm (typ)

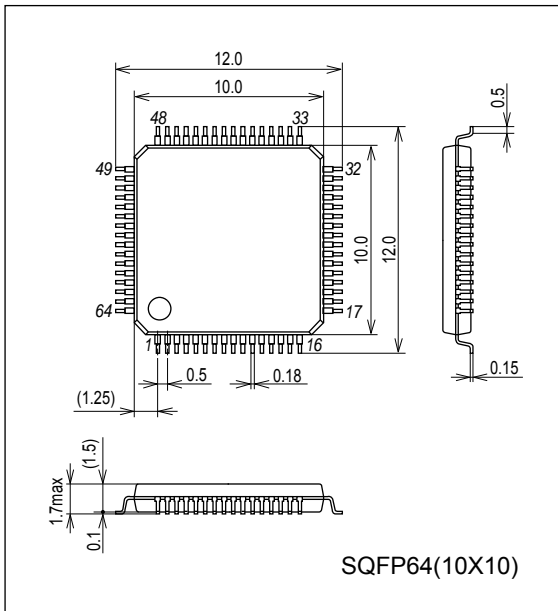

# LC89075WA

## 4. Pin Assignment

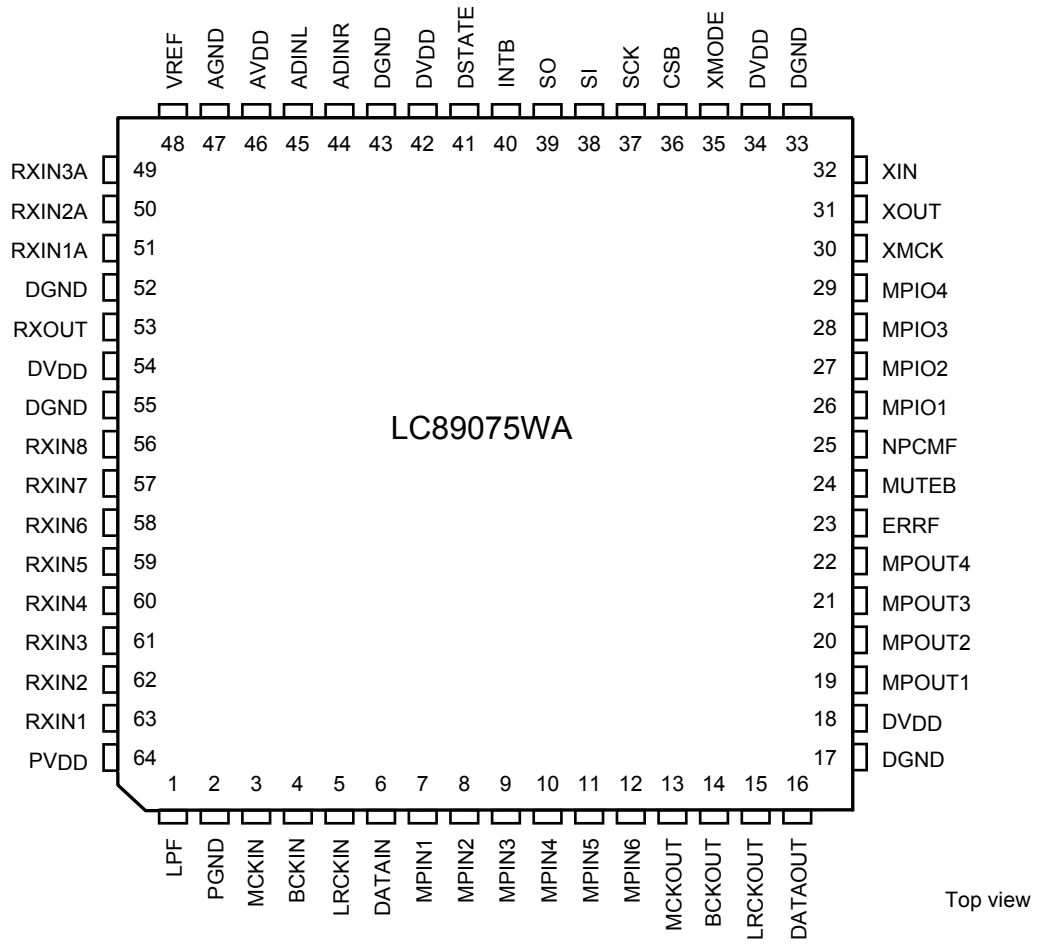

Figure 4.1 LC89075WA Pin Assignment

5. Pin Functions

Table 5.1 Pin Functions

No	Name	I/O	Function
1	LPF	O	PLL: Loop filter connection pin
2	PGND		PLL: Analog GND
3	MCKIN	I	Group A : Master clock input pin to [MCKOUT], [MPOUT1]
			Group A+B : Master clock input pin to [MCKOUT]
4	BCKIN	I	Group A : Bit clock input pin to [BCKOUT], [MPOUT2]
			Group A+B : Bit clock input pin to [BCKOUT]
5	LRCKIN	I	Group A : LR clock input pin to [LRCKOUT], [MPOUT3]
			Group A : DSD data input pin to [LRCKOUT], [MPOUT3]
			Group A+B : LR clock input pin to [LRCKOUT]
6	DATAIN	I	Group A : 2ch audio data input pin to [DATAOUT], [MPOUT4]
			Group A : DSD data input pin to [DATAOUT], [MPOUT4]
			Group A+B : 1, 2ch/8ch audio data input pin to [DATAOUT]
7	MPIN1	I	Group B : Master clock input pin to [MCKOUT], [MPOUT1]
			Group A+B : 3, 4ch/8ch audio data input pin to [MPOUT1]
8	MPIN2	I	Group B : Bit clock input pin to [BCKOUT], [MPOUT2]
			Group A+B : 5, 6ch/8ch audio data input pin to [MPOUT2]
9	MPIN3	I	Group B : LR clock input pin to [LRCKOUT], [MPOUT3]
			Group B : DSD data input pin to [LRCKOUT], [MPOUT3]
			Group A+B : 7, 8ch/8ch audio data input pin to [MPOUT3]
10	MPIN4	I	Group B : 2ch audio data input pin to [DATAOUT], [MPOUT4]
			Group B : DSD data input pin to [DATAOUT], [MPOUT4]
			Group B : 1, 2ch/6ch audio data input pin to [DATAOUT]
			Group A+B : External error signal input pin to [ERRF]
11	MPIN5	I	Group B : 3, 4ch/6ch audio data input pin to [MPOUT1]
			Group A+B : External data mute signal input pin to [MUTEB]
12	MPIN6	I	Group B : 5, 6ch/6ch audio data input pin to [MPOUT2]
			Group A+B : External non-PCM signal input pin to [NPCMF]
13	MCKOUT	O	Master clock output pin from ADC, DIR, [MCKIN], [MPIN1], [MPIO1], [RXIN8]
14	BCKOUT	O	Bit clock output pin from ADC, DIR, [BCKIN], [MPIN2], [MPIO2], [RXIN7]
15	LRCKOUT	O	LR clock output pin from ADC, DIR, [LRCKIN], [MPIN3], [MPIO3], [RXIN6]
			DSD data output pin from [LRCKIN], [MPIN3], [MPIO3], [RXIN6]
16	DATAOUT	O	2ch audio data output pin from ADC, DIR, [DATAIN], [MPIN4], [MPIO4], [RXIN5]
			DSD data output pin from [DATAIN], [MPIN4], [MPIO4], [RXIN5]
			1, 2ch/6ch audio data output pin from [MPIN4]
			1, 2ch/8ch audio data output pin from [DATAIN]
17	DGND		Digital GND
18	DVDD		Digital power supply (3.3V)
19	MPOUT1	O	Master clock output pin from ADC, [MCKIN], [MPIN1], [MPIO1], [RXIN8]
			3, 4ch/6ch audio data output pin from [MPIN5]
			3, 4ch/8ch audio data output pin from [MPIN1]
20	MPOUT2	O	Bit clock output pin from ADC, [BCKIN], [MPIN2], [MPIO2], [RXIN7]
			5, 6ch/6ch audio data output pin from [MPIN6]
			5, 6ch/8ch audio data output pin from [MPIN2]
21	MPOUT3	O	LR clock output pin from ADC, [LRCKIN], [MPIN3], [MPIO3], [RXIN6]
			DSD data output pin from [LRCKIN], [MPIN3], [MPIO3], [RXIN6]
			7, 8ch/8ch audio data output pin from [MPIN3]

Continued on next page.

# LC89075WA

Continued from preceding page.

No	Name	I/O	Function
22	MPOUT4	O	2ch audio data output pin from ADC, [DATAIN], [MPIN4], [MPIO4], [RXIN5]
			DSD data output pin from [DATAIN], [MPIN4], [MPIO4], [RXIN5]
			Input S/PDIF through output pin
23	ERRF	O	PLL lock error, data error flag output pin
			External error signal output pin from [MPIN4]
24	MUTEB	O	Clock switching period data mute signal output pin
			External data mute signal output pin from [MPIN5]
25	NPCMF	O	Channel status data delimiter bit (bit 1) output pin
			External non-PCM signal output pin from [MPIN6]
26	MPIO1	O	Channel status data delimiter bit (bit 1) output pin
			Microcontroller extended register output pin
		I	Master clock input pin (ADC slave operation) to ADC, [MPOUT1]
			Group C : Master clock input pin to [MCKOUT], [MPOUT1]
			3.3V tolerance TTL-compatible S/PDIF input pin
27	MPIO2	O	Channel status copy bit output pin
			Microcontroller extended register output pin
		I	Bit clock input pin (ADC slave operation) to ADC, [MPOUT2]
			Group C : Bit clock input pin to [BCKOUT], [MPOUT2]
			3.3V tolerance TTL-compatible S/PDIF input pin
28	MPIO3	O	Channel status emphasis information output pin
			Microcontroller extended register output pin
		I	LR clock input pin (ADC slave operation) to ADC
			Group C : LR clock input pin to [LRCKOUT], [MPOUT3]
			Group C : DSD data input pin to [LRCKOUT], [MPOUT3]
			3.3V tolerance TTL-compatible S/PDIF input pin
29	MPIO4	O	Channel status age bit output pin
			Microcontroller extended register output pin
			2ch audio data output pin (ADC slave operation) from ADC
		I	Group C : 2ch audio data input pin to [DATAOUT], [MPOUT4]
Group C : DSD data input pin to [DATAOUT], [MPOUT4]			
			3.3V tolerance TTL-compatible S/PDIF input pin
30	XMCK	O	Oscillation amplifier clock output pin
31	XOUT	O	Crystal resonator connection output pin
32	XIN	I	Crystal resonator connection or external clock input pin (12.288MHz or 24.576MHz)
33	DGND		Digital GND
34	DV <sub>DD</sub>		Digital power supply (3.3V)
35	XMODE	I	System reset input pin (when power-on reset is used: fixed at "H")
36	CSB	I	SPI microcontroller I/F, chip enable input pin
37	SCK	I	SPI microcontroller I/F, shift clock input pin
38	SI	I	SPI microcontroller I/F, write data input pin
39	SO	O	SPI microcontroller I/F, read data output pin
40	INTB	O	SPI microcontroller I/F, interrupt signal output pin
41	DSTATE	O	Analog or digital data detection flag output pin
42	DV <sub>DD</sub>		Digital power supply (3.3V)
43	DGND		Digital GND

Continued on next page.

## LC89075WA

Continued from preceding page.

No	Name	I/O	Function
44	ADINR	I <sub>5</sub>	ADC: Analog Rch data input pin
45	ADINL	I <sub>5</sub>	ADC: Analog Lch data input pin
46	AV <sub>DD</sub>		ADC: Analog power supply (5V)
47	AGND		ADC: Analog GND
48	VREF	O	ADC: Common voltage output pin
49	RXIN3A	I	3.3V tolerance TTL-compatible S/PDIF input pin
			Coaxial-compatible S/PDIF input pin
50	RXIN2A	I	3.3V tolerance TTL-compatible S/PDIF input pin
			Coaxial-compatible S/PDIF input pin
51	RXIN1A	I	3.3V tolerance TTL-compatible S/PDIF input pin
			Coaxial-compatible S/PDIF input pin
52	DGND		Digital GND
53	RXOUT	O	Input S/PDIF through output pin
54	DV <sub>DD</sub>		Digital power supply (3.3V)
55	DGND		Digital GND
56	RXIN8	I <sub>5</sub>	5V tolerance TTL-compatible S/PDIF input pin
			Group D : Master clock input pin to [MCKOUT], [MPOUT1]
57	RXIN7	I <sub>5</sub>	5V tolerance TTL-compatible S/PDIF input pin
			Group D : Bit clock input pin to [BCKOUT], [MPOUT2]
58	RXIN6	I <sub>5</sub>	5V tolerance TTL input level S/PDIF input pin
			Group D : LR clock input pin to [LRCKOUT], [MPOUT3]
			Group D : DSD data input pin to [LRCKOUT], [MPOUT3]
59	RXIN5	I <sub>5</sub>	5V tolerance TTL-compatible S/PDIF input pin
			Group D : 2ch audio data input pin to [DATAOUT], [MPOUT4]
			Group D : DSD data input pin to [DATAOUT], [MPOUT4]
60	RXIN4	I <sub>5</sub>	5V tolerance TTL-compatible S/PDIF input pin
61	RXIN3	I <sub>5</sub>	5V tolerance TTL-compatible S/PDIF input pin
62	RXIN2	I <sub>5</sub>	5V tolerance TTL-compatible S/PDIF input pin
63	RXIN1	I <sub>5</sub>	5V tolerance TTL-compatible S/PDIF input pin
64	PV <sub>DD</sub>		PLL: Analog power supply (3.3V)

\* Input tolerance: I = -0.3 to 3.6V, I<sub>5</sub> = -0.3 to 5.5V, Output tolerance: O = -0.3 to 3.6V

\* Pin 35: it has a built-in power-on reset circuit.

\* Pin 32: power-off reverse bias control is supported only when a resonator is connected.

\* Pins 26, 27, 28 and 29: power-off reverse bias control are supported only when "L" level input during power-off.

\* Pin 46: 3.3V can be supplied when not using the ADC. In this case, making the power-down setting is recommended.

\* Each AV<sub>DD</sub>, PV<sub>DD</sub> and DV<sub>DD</sub> power supply must be turned on and off at the same timing to prevent latch-up.

6. Block Diagram

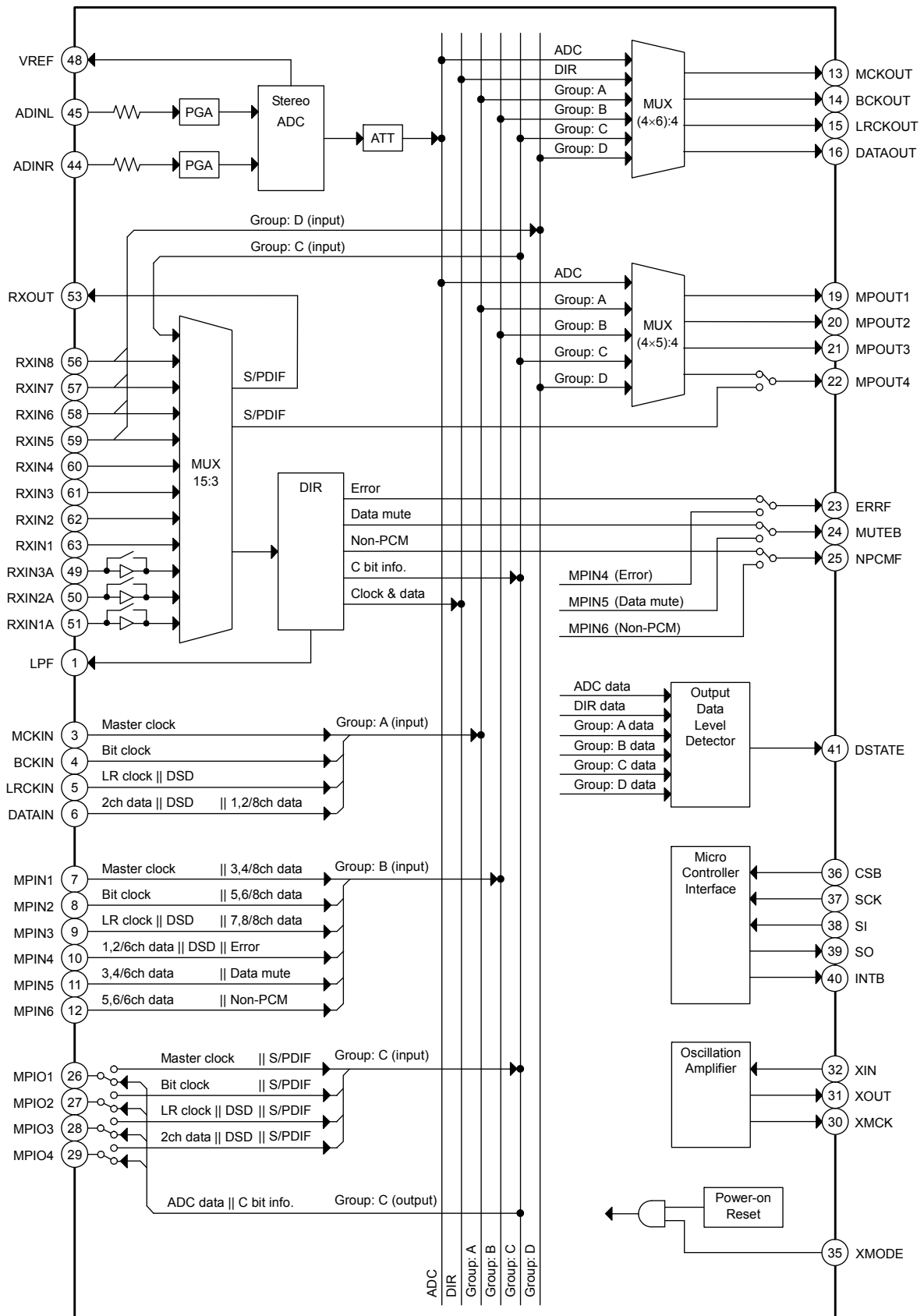

Figure 6.1 LC89075WA Block Diagram

## 7. Electrical Characteristics

### 7.1 Absolute Maximum Ratings

Table 7.1 Absolute Maximum Ratings at AGND=PGND=DGND=0V

Parameter	Symbol	Conditions	Ratings	Unit
Maximum supply voltage	AV <sub>DD</sub> max	7.1.1	-0.3 to 6.0	V
Maximum supply voltage	DV <sub>DD</sub> max	7.1.2	-0.3 to 4.6	V
Input voltage 1	V <sub>IN1</sub>	7.1.3	-0.3 to AV <sub>DD</sub> max+0.3 (max.6.0Vp-p)	V
Input voltage 2	V <sub>IN2</sub>	7.1.4	-0.3 to DV <sub>DD</sub> max+0.3 (max.4.6Vp-p)	V
Output voltage	V <sub>OUT</sub>	7.1.5	-0.3 to DV <sub>DD</sub> max+0.3 (max.4.6Vp-p)	V
Storage ambient temperature	T <sub>stg</sub>		-55 to 125	°C
Operating ambient temperature	T <sub>opr</sub>		-30 to 85	°C
Allowable power dissipation	P <sub>d</sub> max	7.1.6	559	mW
Maximum input/output current	I <sub>IN</sub> , I <sub>OUT</sub>	7.1.7	±20	mA

7.1.1: AV<sub>DD</sub> pin

7.1.2: PV<sub>DD</sub> and DV<sub>DD</sub> pins

7.1.3: ADINL, ADINR, RXIN1, RXIN2, RXIN3, RXIN4, RXIN5, RXIN6, RXIN7, and RXIN8 pins

7.1.4: MCKIN, BCKIN, LRCKIN, DATAIN, MPIN1, MPIN2, MPIN3, MPIN4, MPIN5, and MPIN6 pins

XIN, MPIO1, MPIO2, MPIO3, MPIO4, XMODE, CSB, SCK, SI, RXIN1A, RXIN2A, and RXIN3A pins

7.1.5: MCKOUT, BCKOUT, LRCKOUT, DATAOUT, MPOUT1, MPOUT2, MPOUT3, MPOUT4, and ERRF pins

MUTE<sub>B</sub>, NPCMF, XMCK, XOUT, MPIO1, MPIO2, MPIO3, MPIO4, SO, INTB, DSTATE, and RXOUT pins

7.1.6: Ta ≤ 85°C

7.1.7: Per input/output pin

Stresses exceeding Maximum Ratings may damage the device. Maximum Ratings are stress ratings only. Functional operation above the Recommended Operating Conditions is not implied. Extended exposure to stresses above the Recommended Operating Conditions may affect device reliability.

### 7.2 Allowable Operating Range

Table 7.2 Recommended Operating Conditions at AGND=PGND=DGND=0V

Parameter	Symbol	Conditions	min	typ	max	Unit
Supply voltage 1	AV <sub>DD1</sub>	7.2.1	4.5	5.0	5.5	V
Supply voltage 2	AV <sub>DD2</sub>	7.2.2	3.0	3.3	3.6	V
Supply voltage 3	DV <sub>DD</sub>	7.2.3	3.0	3.3	3.6	V
Input voltage range 1	V <sub>IN1</sub>	7.2.4	0		5.5	V
Input voltage range 2	V <sub>IN2</sub>	7.2.5	0		3.6	V
Output load capacitance 1	C <sub>L1</sub>	7.2.6			20	pF
Output load capacitance 2	C <sub>L2</sub>	7.2.7			30	pF
Operating temperature	V <sub>opr</sub>		-30	25	85	°C

7.2.1: AV<sub>DD</sub> pin (when ADC is used)

7.2.2: AV<sub>DD</sub> pin (ADC must be set to power-down mode at all times. “ADCOPR[1:0]=11”)

7.2.3: PV<sub>DD</sub> and DV<sub>DD</sub> pins

On/off of AV<sub>DD</sub>, PV<sub>DD</sub>, and DV<sub>DD</sub> should desirably be done at the same timing. If that is not possible, PV<sub>DD</sub> and DV<sub>DD</sub> must be turned on earlier than AV<sub>DD</sub>. AV<sub>DD</sub> must also be turned off after PV<sub>DD</sub> and DV<sub>DD</sub>.

7.2.4: ADINL, ADINR, RXIN1, RXIN2, RXIN3, RXIN4, RXIN5, RXIN6, RXIN7, and RXIN8 pins

7.2.5: MCKIN, BCKIN, LRCKIN, DATAIN, MPIN1, MPIN2, MPIN3, MPIN4, MPIN5, and MPIN6 pins

XIN, MPIO1, MPIO2, MPIO3, MPIO4, XMODE, CSB, SCK, SI, RXIN1A, RXIN2A, and RXIN3A pins

7.2.6: MCKOUT pin

7.2.7: Output pins other than MCKOUT



# LC89075WA

## 7.3 Analog to Digital Converter Characteristics

Table 7.3 ADC Characteristics at Ta=25°C, AVDD=5.0V, PVDD=DVDD=3.3V, AGND=PGND=DGND=0V  
fs=48k: 96kHz, input=1kHz: 24-bit data, measurement=20Hz to 20kHz

Parameter	Conditions	min	typ	max	Unit
Resolution				24	bits
Sampling frequency	7.3.1	8	48	96	kHz
System clock frequency		2.048	12.288	24.576	MHz
Input voltage	7.3.2		3.0		Vp-p
PGA range	7.3.3	-4.5	0	6	dB
PGA step	7.3.3		1.5		dB
THD+N	7.3.4 (48kHz)		-92	-80	dB
	7.3.5 (96kHz)		-88		dB
S/N	7.3.6 (48kHz)	94	101		dB
	7.3.7 (96kHz)		103		dB
Dynamic range	7.3.8 (48kHz)	94	101		dB
	7.3.9 (96kHz)		103		dB
Input impedance			27		kΩ
Channel-to-channel crosstalk		90	100		dB
Channel gain error			0.2	0.5	dB
Pass band				0.45fs	Hz
Stop band		0.545fs			Hz
Pass band ripple				±0.041	dB
Stop band attenuation		-58.5			dB
Group delay	7.3.10		24.5		1/fs
HPF frequency response	7.3.11		0.0385fs/1000		

7.3.1: Sampling frequency is 6kHz when “ADCOPR[1:0]=10” and “SDMODE=1”.

7.3.2: Proportional to AVDD voltage with a full scale value (0dB) of analog input voltage (VIN=0.6×AVDD)

7.3.3: -4.5dB to 6dB/1.5dB steps

7.3.4: fs=48kHz, -1dBFS, except when “ADCOPR[1:0]=10”

7.3.5: fs=96kHz, -1dBFS, except when “ADCOPR[1:0]=10”

7.3.6: fs=48kHz, A-weighted, except when “ADCOPR[1:0]=10”

7.3.7: fs=96kHz, A-weighted, except when “ADCOPR[1:0]=10”

7.3.8: fs=48kHz, -60dBFS, A-weighted

7.3.9: fs=96kHz, -60dBFS, A-weighted

7.3.10: Delay calculation for the digital filter

7.3.11: -3dB

# LC89075WA

## 7.4 DC Characteristics

Table 7.4 DC Characteristics at Ta=-30 to 85°C,  
AVDD=4.5 to 5.5V, PVDD=DVDD=3.0 to 3.6V, AGND=PGND=DGND=0V

Parameter	Symbol	Conditions	min	typ	max	Unit
Input, High	V <sub>IH</sub>	7.4.1	0.7 DV <sub>DD</sub>			V
Input, Low	V <sub>IL</sub>					
Input, High	V <sub>IH</sub>	7.4.2	2.0			V
Input, Low	V <sub>IL</sub>					
Output, High	V <sub>OH</sub>	7.4.3	V <sub>DD</sub> -0.8			V
Output, Low	V <sub>OL</sub>					
Input amplitude	V <sub>P-P</sub>	7.4.4	200			mV
Input impedance	Z <sub>in</sub>	7.4.4	40		65	kΩ

7.4.1: CMOS-compatible: XIN input pin

7.4.2: TTL-compatible: Input pins other than XIN, ADINL, and ADINR pins

7.4.3: I<sub>OH</sub>=-6mA, I<sub>OL</sub>=6mA: MCKOUT, and MPOUT1 output pins

I<sub>OH</sub>=-4mA, I<sub>OL</sub>=4mA: BCKOUT, LRCKOUT, DATAOUT, MPOUT[4:2], XMCK, and RXOUT output pins

I<sub>OH</sub>=-2mA, I<sub>OL</sub>=2mA: ERRE, MUTE, NPCMF, MPIO[4:1], SO, INTB, and DSTATE output pins

7.4.4: Before capacitance of RXIN1A, RXIN2A, and RXIN3A pins (when coaxial input is set to RXIN1A, RXIN2A, and RXIN3A)

## 7.5 Supply Current Characteristics

Table 7.5 DC Characteristics at Ta=25°C,  
AVDD=5V, PVDD=DVDD=3.3V, AGND=PGND=DGND=0V, Minimum load on output pins

Parameter	Symbol	Conditions	min	typ	max	Unit
AVDD Supply Current	I <sub>ADD</sub>	7.5.1		0.1	4	μA
PVDD, DVDD Supply Current	I <sub>DDD</sub>					
AVDD Supply Current	I <sub>ADD</sub>	7.5.2		28	36	mA
PVDD, DVDD Supply Current	I <sub>DDD</sub>					
AVDD Supply Current	I <sub>ADD</sub>	7.5.3		28	36	mA
PVDD, DVDD Supply Current	I <sub>DDD</sub>					
AVDD Supply Current	I <sub>ADD</sub>	7.5.4		28	36	mA
PVDD, DVDD Supply Current	I <sub>DDD</sub>					
AVDD Supply Current	I <sub>ADD</sub>	7.5.5		3	4	mA
PVDD, DVDD Supply Current	I <sub>DDD</sub>					
AVDD Supply Current	I <sub>ADD</sub>	7.5.6		3	4	mA
PVDD, DVDD Supply Current	I <sub>DDD</sub>					

7.5.1: XMODE=L, XIN=12.288MHz

7.5.2: XIN=24.576MHz, MCKOUT=512fs, fs=44.1kHz/DIR, ADC=Reset status

7.5.3: XIN=24.576MHz, MCKOUT=256fs, fs=96kHz/DIR, fs=48kHz/ADC, ADINL=ADINR=1kHz/Sine, "SW2SEL[2:0]=001", "SW1SEL[2:0]=000", "RXDSEL[3:0]=0000"

7.5.4: XIN=24.576MHz, MCKOUT=128fs, fs=192kHz/DIR, fs=96kHz/ADC, ADINL=ADINR=1kHz/Sine, "SW2SEL[2:0]=001", "SW1SEL[2:0]=000", "RXDSEL[3:0]=0000"

7.5.5: Analog audio data detection setting standby current,

"ADCOPR[1:0]=10", "SDMODE=1", XIN=24.576MHz, fs=6kHz/ADC, when Figure 9.6 setting ADINL=ADINR=No signal

7.5.6: Analog and digital audio data detection setting standby current,

"ADCOPR[1:0]=10", "SDMODE=1", "DSTASEL=1", XIN=24.576MHz, fs=6kHz/ADC, when Figure 9.6 setting, however "DIOPR=0", "RXDSEL[3:0]=0000"

ADINL=ADINR=No signal, S/PDIF dose not input

# LC89075WA

## 7.6 AC Characteristics 1

Table 7.6 AC Characteristics at Ta=-30 to 85°C,  
AVDD=4.5 to 5.5V, PVDD=DVDD=3.0 to 3.6V, AGND=PGND=DGND=0V

Parameter	Symbol	Conditions	min	typ	max	Unit
RXIN1 to 8, RXIN1A to 3A MPIO[4:1] input receive frequency	f <sub>RFS</sub>		28		195	kHz
RXIN1 to 8, RXIN1A to 3A MPIO[4:1] input duty factor	t <sub>RXDUY</sub>		40	50	60	%
XIN clock input frequency	f <sub>XF</sub>	7.6.1		12.288		MHz
		7.6.2		24.576		MHz
XIN clock input duty factor	f <sub>XDUY</sub>		40	50	60	%
MCKOUT clock output frequency	f <sub>MCK1</sub>		4		50	MHz
MCKOUT clock output duty factor	f <sub>MCKDUY</sub>		40	50	60	%
MCKOUT clock jitter	T <sub>j</sub>	7.6.3		50		ps RMS
MPOUT1 clock output frequency	f <sub>MCK2</sub>		2		25	MHz
BCKOUT, MPOUT2 clock output frequency	f <sub>BCK4</sub>		0.5		12.5	MHz
LRCKOUT, MPOUT3 clock output frequency	f <sub>LRCK4</sub>		8		192	kHz
MCKOUT-BCKOUT output delay	t <sub>MBO</sub>		-10		10	ns
BCKOUT-LRCKOUT output delay	t <sub>BLO</sub>	7.6.4	-10		10	ns
BCKOUT-DATAOUT output delay	t <sub>BDO</sub>	7.6.4	-10		10	ns
BCKOUT-MPOUT[3:1](6ch, 8ch) output delay		7.6.5	-10		10	ns
LRCKOUT-DATAOUT output delay	t <sub>LDO</sub>		-10		10	ns
LRCKOUT-MPOUT[3:1](6ch, 8ch) output delay		7.6.5	-10		10	ns

7.6.1: "XINSEL[1:0]=00"

7.6.2: Other than "XINSEL[1:0]=00"

7.6.3: Period jitter value

7.6.4: This also applies to the output when DSD data is input.

7.6.5: "SW1SEL[1:0]=010 or 011", "SW2SEL[1:0]=110 or 111"

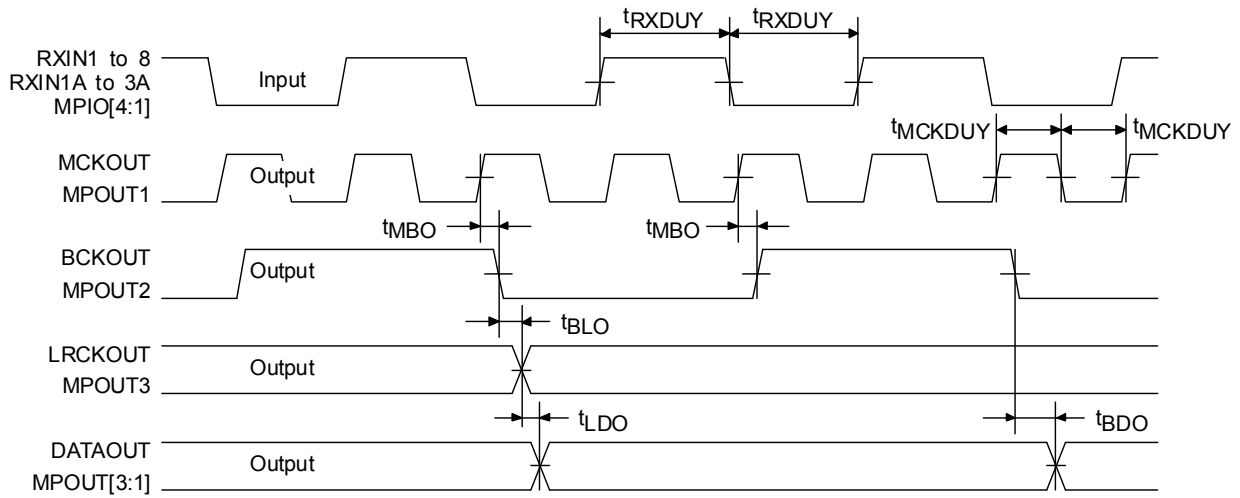

Figure 7.1 AC Characteristics 1

7.7 AC Characteristics 2

Table 7.7 AC Characteristics at Ta=-30 to 85°C,  
 AVDD=4.5 to 5.5V, PVDD=DVDD=3.0 to 3.6V, AGND=PGND=DGND=0V

Parameter	Symbol	Conditions	min	typ	max	Unit
Master clock input/output frequency	f <sub>MCKIN1</sub>	7.7.1	2		25	MHz
Bit clock input/output frequency	f <sub>BCKIN</sub>	7.7.2	0.5		12.5	MHz
LR clock input/output frequency	f <sub>LRCKIN</sub>	7.7.3	8		195	kHz
Input delay	t <sub>IDLY</sub>	7.7.4	0		40	ns
Setup/hold	t <sub>BDSH</sub>	7.7.5	25			ns
Master clock input/output delay	t <sub>MMO</sub>	7.7.6			25	ns
Bit clock input/output delay	t <sub>BBO</sub>	7.7.7			25	ns
LR clock input/output delay	t <sub>LLO</sub>	7.7.8			25	ns
Data input/output delay	t <sub>DDO</sub>	7.7.9			25	ns

- 7.7.1: MCKIN, MPIN1, MPIO1, and RXIN8 input pins, MCKOUT and MPOUT1 output pins
- 7.7.2: BCKIN, MPIN2, MPIO2, and RXIN7 input pins, BCKOUT and MPOUT2 output pins
- 7.7.3: LRCKIN, MPIN3, MPIO3, and RXIN6 input pins, LRCKOUT and MPOUT3 output pins
- 7.7.4: MPIO2 to MPIO3 input pin-to-pin delay when in ADC slave operation
- 7.7.5: DATAIN, MPIN1, MPIN2, MPIN3, MPIN4, MPIN5, MPIN6, MPIO4, and RXIN5 input pins
- 7.7.6: MCKIN-MCKOUT, MPIN1-MCKOUT, MPIO1-MCKOUT, and RXIN8-MCKOUT I/O pin-to-pin delay  
 MCKIN-MPOUT1, MPIN1-MPOUT1, MPIO1-MPOUT1, and RXIN8-MPOUT1 I/O pin-to-pin delay
- 7.7.7: BCKIN-BCKOUT, MPIN2-BCKOUT, MPIO2-BCKOUT, and RXIN7-BCKOUT I/O pin-to-pin delay  
 BCKIN-MPOUT2, MPIN2-MPOUT2, MPIO2-MPOUT2, and RXIN7-MPOUT2 I/O pin-to-pin delay
- 7.7.8: LRCKIN-LRCKOUT, MPIN3-LRCKOUT, MPIO3-LRCKOUT, and RXIN6-LRCKOUT I/O pin-to-pin delay  
 LRCKIN-MPOUT3, MPIN3-MPOUT3, MPIO3-MPOUT3, and RXIN6-MPOUT3 I/O pin-to-pin delay
- 7.7.9: DATAIN-DATAOUT, MPIN4-DATAOUT, MPIO4-DATAOUT, and RXIN5-DATAOUT I/O pin-to-pin delay  
 DATAIN-MPOUT4, MPIN4-MPOUT4, MPIO4-MPOUT4, and RXIN5-MPOUT4 I/O pin-to-pin delay  
 MPIN1-MPOUT1, MPIN2-MPOUT2, and MPIN3-MPOUT3 I/O pin-to-pin delay  
 MPIN5-MPOUT1 and MPIN6-MPOUT2 I/O pin-to-pin delay

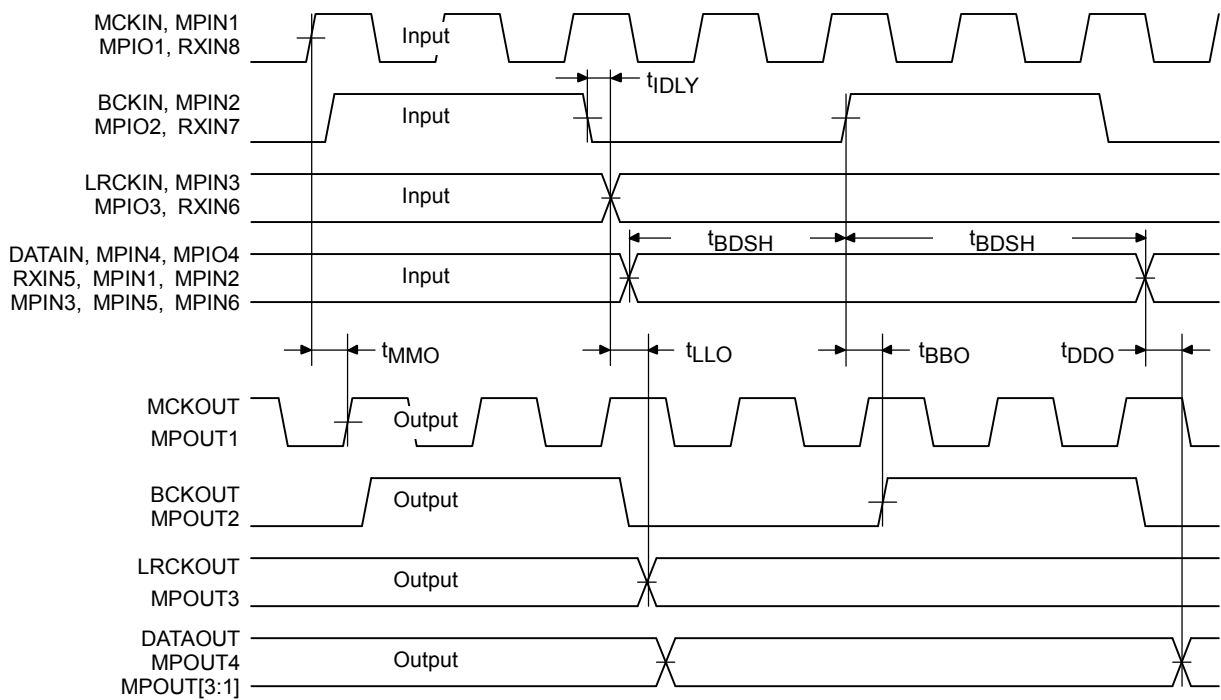

Figure 7.2 AC Characteristics 2

## 7.8 SPI Microcontroller Interface AC Characteristics

Table 7.8 AC Characteristics at Ta=-30 to 85°C,  
 AVDD=4.5 to 5.5V, PVDD=DVDD=3.0 to 3.6V, AGND=PGND=DGND=0V

Parameter	Symbol	Conditions	min	typ	max	Unit
Power-on reset DVDD slope	tPORSL	7.8.1			100	ms
XMODE input pulse width (L)	tRSTdw	7.8.2	200			μs
SCK input frequency	fSCK				10	MHz
SCK input pulse width (L)	tSCKdw		40			ns
SCK input pulse width (H)	tSCKuw		40			ns
CSB input pulse width (H)	tCSBuw		80			ns
CSB-SCK input delay	tCSBtoSCK		20			ns
CSB-SCK hold	tCSBhold		20			ns
SCK-SI setup	tSIsetup		15			ns
SCK-SI hold	tSIhold		15			ns
SCK-SO output delay	tSCKtoSO				25	ns
CSB-SO output delay	tCSBtoSO				20	ns

7.8.1: Each AVDD, PVDD and DVDD power supply must be turned on and off at the same timing.

7.8.2: XMODE must be fixed to “H” before power is turned on in order to use the power-on reset function.

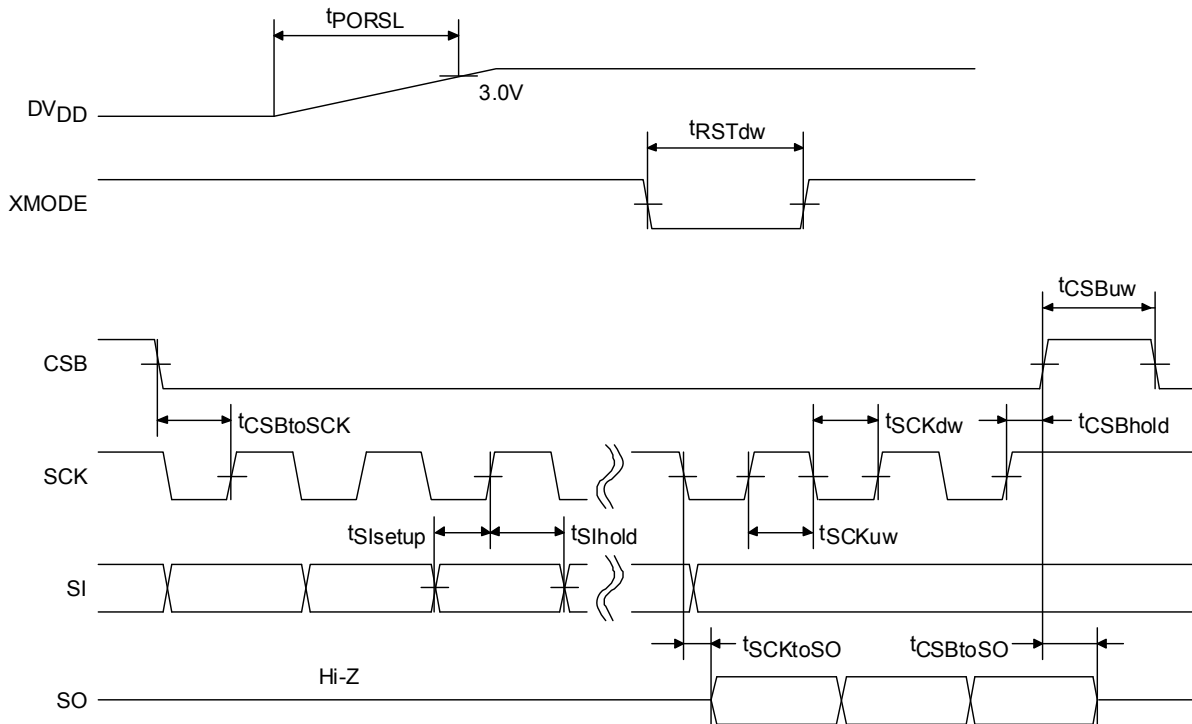

Figure 7.3 SPI Microcontroller Interface AC Characteristics

## 8. System Settings (Common to ADC, DIR, and Audio selector)

### 8.1 Oscillation Amplifier Pin Settings (XIN, XOUT, XMCK)

- The LC89075WA features a built-in oscillation amplifier. Connect a quartz resonator, feedback resistor, and load capacitance to XIN and XOUT to configure an oscillation circuit. The figure below shows the connection diagram. When connecting a quartz resonator, use one with a fundamental wave, and be aware that the load capacitance depends on the quartz resonator characteristics, so thorough investigation should be made.
- If the built-in oscillation amplifier is not used and an oscillation module is used as the clock source instead, connect the output of an external clock supply source to XIN. At this time, it is not necessary to connect a feedback resistor between XIN and XOUT.
- Always supply a 12.288MHz or 24.576MHz clock to XIN.
- The clock frequency is set with the XINSEL[1:0] register. The clock frequency set with the XINSEL[1:0] register and the clock frequency input to XIN must match.
- The clock set with the XINSEL[1:0] register is defined as the ADC operation clock and the MCKOUT, BCKOUT, and LRCKOUT output clocks when ADC data output is selected. Complete the XINSEL[1:0] register setting prior to bi-phase data input.
- XMCK outputs the XIN clock. The XMCK output is set with the XMSEL[1:0] register. 1/1, 1/2 or 1/4 of the XIN clock, or “L” output can be set.

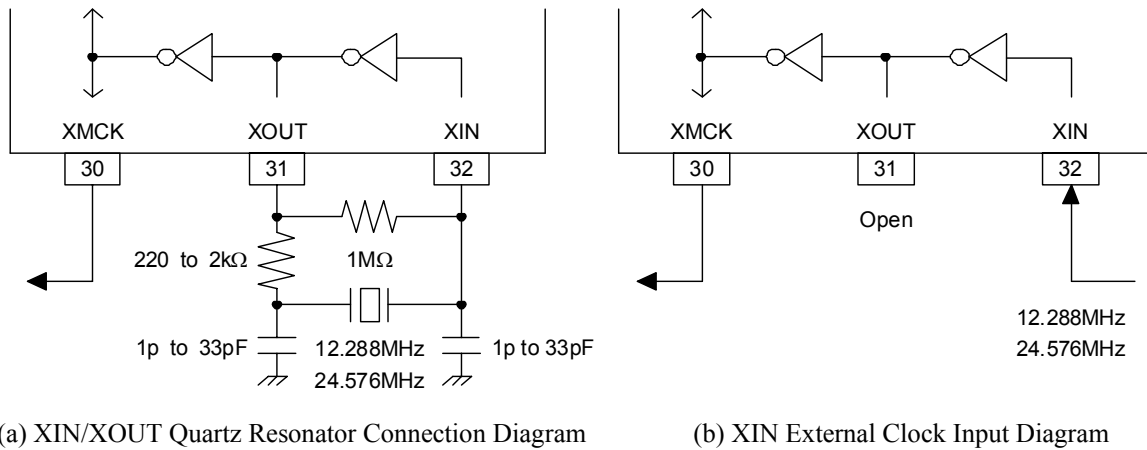

Figure 8.1 XIN/XOUT External Circuit Connection Diagram

### 8.2 ADC Common Voltage Output Pin Setting (VREF)

- VREF is used as the ADC analog signal common voltage and outputs the  $1/2AV_{DD}$  voltage.
- Connect  $10\mu\text{F}$  and  $0.1\mu\text{F}$  capacitors between VREF and AGND, as close to the pins as possible. In addition, do not position clock or digital signal wiring close to these capacitors to avoid coupling to the converter.

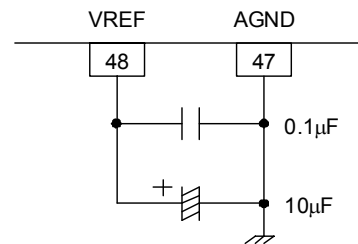

Figure 8.2 VREF External Circuit Connection Diagram

### 8.3 DIR Loop Filter Pin Setting (LPF)

- The DIR incorporates a VCO (Voltage Controlled Oscillator) that synchronizes with sampling frequencies from 32kHz to 192kHz and with the data with a transfer rate from 4MHz to 25MHz.
- The PLL is locked at 512fs.
- LPF is a pin for the PLL loop filter. Connect the resistor and capacitors shown in the right figure, as close to the pin as possible.

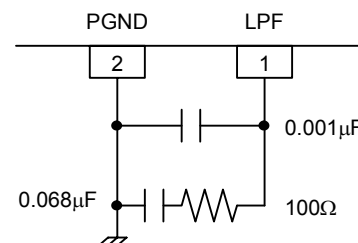

Figure 8.3 LPF External Circuit Connection Diagram

## 8.4 System Reset (XMODE)

- The LC89075WA features a built-in power-on reset circuit, and constantly monitors the power supply status.
- When XMODE is set to “H” and the power is turned on, the system is reset by this power-on reset circuit.
- When not using the power-on reset circuit, always set XMODE to “L” to reset the system during power-on. The system operates correctly when XMODE is set to “H” after the reset sequence. When XMODE is set to “L” again thereafter, the system is reset.

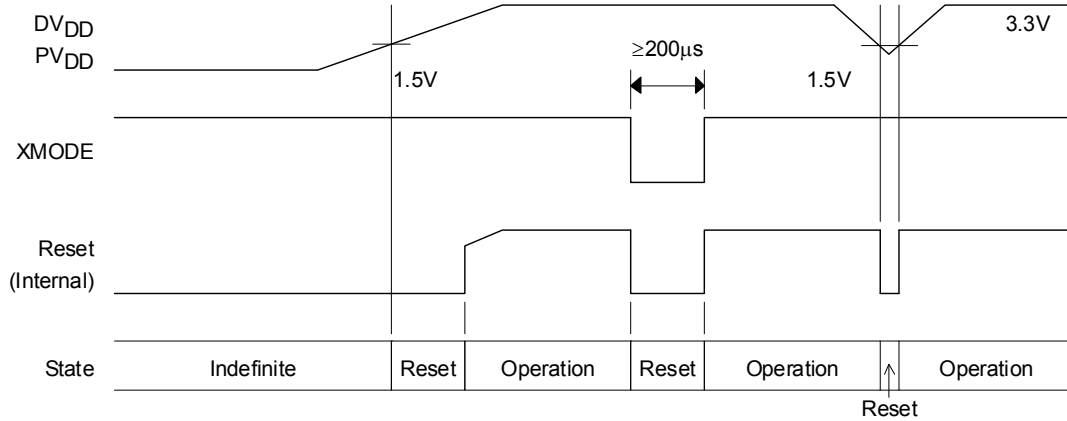

Figure 8.4 Power-on Reset and XMODE Reset Timing Chart

Table 8.1 Functional Block States When XMODE Is Reset (XMODE=“L”)

Functional Block	State
ADC	Stopped, power-down mode
DIR	Stopped, power-down mode (PLL stopped)
Oscillation amplifier	Running
Microcontroller registers	Initial Value

Table 8.2 Output Pin States When XMODE Is Reset (XMODE=“L”)

Pin No.	Pin Name	Output State	Pin No.	Pin Name	Output State
13	MCKOUT	Output (XIN)	26	MPIO1	Hi-Z
14	BCKOUT	L	27	MPIO2	Hi-Z
15	LRCKOUT	L	28	MPIO3	Hi-Z
16	DATAOUT	L	29	MPIO4	Hi-Z
19	MPOUT1	L	30	XMCK	Output
20	MPOUT2	L	31	XOUT	Output
21	MPOUT3	L	39	SO	Hi-Z
22	MPOUT4	L	40	INTB	H
23	ERRF	H	41	DSTATE	L
24	MUTE B	L	53	RXOUT	L
25	NPCMF	L			

8.5 Output Data Format (Common to the ADC and DIR Blocks)

- The DATAOUT and MPOUT[4:1] output data format is set with the DAFORM register.
- The initial value of the output format is I<sup>2</sup>S. Data is output synchronized with the BCKOUT falling edge.

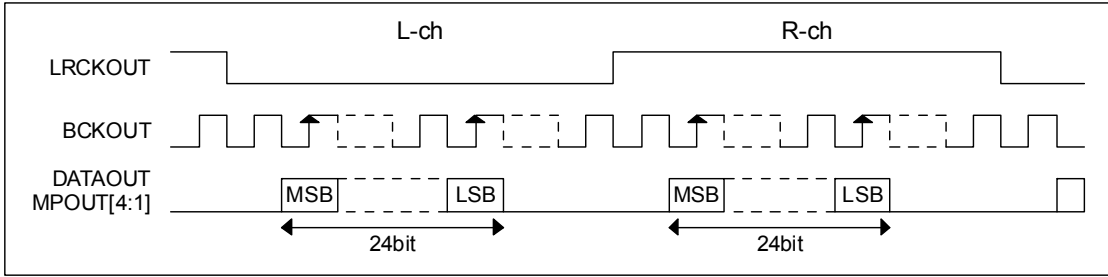

“DAFORM=0”: I<sup>2</sup>S Data Output

MPOUT[4:1]: Excluded when the clock output function is used

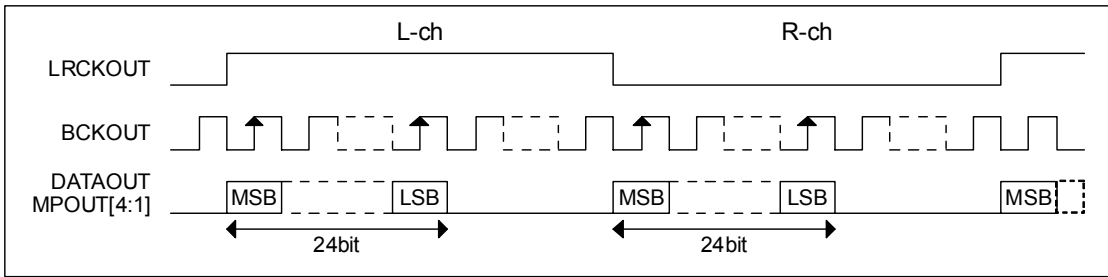

“DFORM=1”: MSB First Left-Justified Output

Figure 8.5 ADC and DIR Data Output Timing Chart

8.6 Handling of Unused Pins

- Leave unused output pins open, and set unused input pins as shown in the table below.
- Always set input pins not noted in the table below as described in these specifications.

Table 8.3 Settings of Unused Input Pins

Pin No.	Pin Name	Input Setting	Pin No.	Pin Name	Input Setting
3	MCKIN	Connect to DGND (Pin No. 14)	44	ADINR	Open
4	BCKIN	Connect to DGND (Pin No. 14)	45	ADINL	Open
5	LRCKIN	Connect to DGND (Pin No. 14)	49	RXIN3A	Connect to DGND (Pin No. 52)
6	DATAIN	Connect to DGND (Pin No. 14)	50	RXIN2A	Connect to DGND (Pin No. 52)
7	MPIN1	Connect to DGND (Pin No. 14)	51	RXIN1A	Connect to DGND (Pin No. 52)
8	MPIN2	Connect to DGND (Pin No. 14)	56	RXIN8	Connect to DGND (Pin No. 55)
9	MPIN3	Connect to DGND (Pin No. 14)	57	RXIN7	Connect to DGND (Pin No. 55)
10	MPIN4	Connect to DGND (Pin No. 14)	58	RXIN6	Connect to DGND (Pin No. 55)
11	MPIN5	Connect to DGND (Pin No. 14)	59	RXIN5	Connect to DGND (Pin No. 55)
12	MPIN6	Connect to DGND (Pin No. 14)	60	RXIN4	Connect to DGND (Pin No. 55)
37	CSB	Connect to DGND (Pin No. 43)	61	RXIN3	Connect to DGND (Pin No. 55)
38	SCK	Connect to DGND (Pin No. 43)	62	RXIN2	Connect to DGND (Pin No. 55)
39	SI	Connect to DGND (Pin No. 43)	63	RXIN1	Connect to DGND (Pin No. 55)

- The MPIO[4:1] pins can be set to input or output. In the initial status, these pins are set to output of Hi-Z. When not using these pins, use the initial setting and leave the pins open.



## 9. Description of Analog to Digital Converter (ADC)

### 9.1 Operation Settings

- ADC operation can be selected from the automatic stop mode that follows DIR operation, continuous operation mode, low sampling rate operation mode, and power-down mode. The initial value is set to the automatic stop mode that follows DIR operation.

Table 9.1 ADC Operation Mode Comparison

Mode Setting	ADC State
Automatic stop mode (initial value)	When PLL is unlocked: Operating When PLL is locked: Reset (ADC also resets when ERRF is "H" and PLL is locked)
Continuous operation mode	Always operating
Low sampling rate operation mode	Operating (ADC's rate fixed at 6kHz)
Power-down mode	Complete stop

#### 9.1.1 Automatic Stop Mode

- The automatic stop mode function sets ADC operation with priority on the DIR status, and controls ADC operation according to the PLL locked status and ERRF output status. ("ADCOPR[1:0]=00")
- The ADC is automatically set to the reset status in the PLL locked status. When the PLL changes to the unlocked status, the reset is canceled and the ADC restarts analog to digital conversion. However, ADC is set to the reset status when ERRF is "H" and PLL is locked. (when "RXRESEL=1" or "RXRESTA=1")
- When setting the ADC to automatic stop mode, it is recommended to simultaneously make the oscillation amplifier stop setting. The oscillation amplifier can be automatically stopped while the PLL is locked, by "AMPOPR[1:0]=01". This eliminates the possibility of coexistence of the XIN clock and PLL clock, enabling reduction of interference between the clocks. However, this excludes cases when the XIN clock cannot be stopped, such as when the oscillation amplifier clock output XMCK is constantly supplied to the DSP, etc.

#### 9.1.2 Continuous Operation Mode

- The ADC can be set to the continuous operation mode that constantly continues analog to digital conversion operation regardless of the DIR status.
- Continuous operation mode can be set in the following states. This setting has priority over automatic stop mode.
  - When the ADC clock and data are set to constant output: "SW1SEL[2:0]=001" or "SW2SEL[2:0]=001"
  - When ADC slave operation is set: "MPSEL[1:0]=10 or 11"

#### 9.1.3 Low Sampling Rate Operation Mode

##### (Analog Audio Data Detection in Power Save Operation Mode)

- The low sampling rate operation mode performs analog audio data detection with low power consumption.
- To set this mode, both "ADCOPR[1:0]=10" and "SDMODE=1" must be set. These registers need to detect the existence of analog audio data in power save operation. When only the ADCOPR[1:0] register or the SDMODE register is set, this function does not operate.
- Low sampling rate operation mode operates only when set to master mode. When the ADC is operated in slave mode, low sampling rate operation cannot be set.
- After this mode is set, the ADC performs analog to digital conversion at a sampling rate of 6kHz.
- Current consumption can be further reduced by simultaneously setting to stop the DIR function and fix the output clock pin outputs to suppress current consumption other than the ADC. See below for further details, "9.6 Analog Audio Data Detection".

9.1.4 Power-down Mode

- The ADC is set to power-down mode by “ADCOPR[1:0]=11”. In power-down mode, VREF is set to the AGND voltage.
- Power-on reset when turning the power on and system start-up from power-down mode are both executed via the ADC initialization cycle. Reset by power-on-reset or ADC initialization after power-down mode is canceled require a period of 85ms.
- The ADC advances the reset cancel when initialization is complete. Normally, 16384/fs period needs for the reset cancel. The offset generated in initial data of ADC is removed for this period. When the reset cancel period dose not need, it sets by the ADBMOD register. (“ADBMOD=1”)
- DATAOUT outputs data “0” during power-down mode and reset cancel period.
- The ADC starts analog to digital conversion after reset is canceled. The digital data is output after fade-in processing by the digital volume. In addition, switching from normal operation to power-down mode is executed after fade-out processing.
- In cases such as when slave mode or an oscillation module is not used and an external clock is supplied instead, the clock may be disrupted when switching to power-down mode, and noise may be generated. In these cases, set power-down mode after performing soft mute processing. See below for further details, “9.5 Soft Mute/Attenuator”.

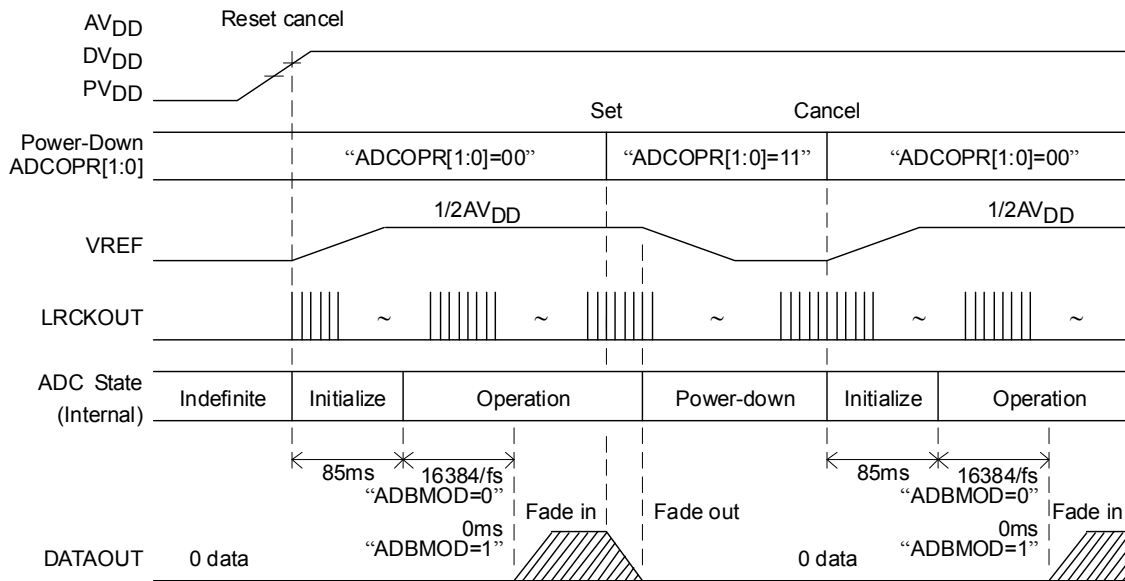

Figure 9.1 Timing Chart for Power-down Mode and When the Mode is Canceled

9.1.5 When Not Using the ADC

- When not using the built-in ADC, 3.3V can be supplied to the AVDD pin that normally requires a 5V supply.
- The ADC can operate even when 3.3V is supplied, but the characteristics are not guaranteed. Therefore, it is recommended to set the power-down mode when not using the ADC.

## 9.2 Clock Input Settings (XIN, XOUT, XMCK)

- The ADC normally operates in master mode, and can be switched to slave mode by the register setting.

### 9.2.1 Master Mode 1 (Continuous Operation Mode and Automatic Stop Mode)

- In master mode, the sampling frequency operates at 48kHz or 96kHz.
- Master mode operates using the 12.288MHz or 24.576MHz clock input to the XIN pin.
- The clock set with the XINSEL[1:0] register is supplied to the ADC.
- The clock supplied to the ADC is output from MCKOUT, BCKOUT, LRCKOUT and MPOUT[3:1] when ADC data output is selected.

Table 9.2: ADC Supplied Clock and Output Clocks in Master Mode (Initial Value: “XINSEL[1:0]=00”)

XINSEL[1:0]		XIN Pin Input Clock Frequency (Hz)	ADC Sampling Frequency (Hz)	Output Pin Clock Frequency (Hz)		
				MCKOUT MPOUT1	BCKOUT MPOUT2	LRCKOUT MPOUT3
0	0	12.288M	48k	12.288M	3.072M	48k
0	1	24.576M	48k	12.288M	3.072M	48k
1	0	24.576M	48k	24.576M	3.072M	48k
1	1	24.576M	96k	24.576M	6.144M	96k

### 9.2.2 Master Mode 2 (Low Sampling Rate Operation Mode)

- Operation is performed at the 12.288MHz or 24.576MHz clock input to the XIN pin, but analog to digital conversion is performed at a sampling frequency of 6kHz. See below for further details, “9.6 Analog Audio Data Detection”.

### 9.2.3 Slave Mode

- Slave mode sets clock input and data output pins exclusively for the ADC, and performs analog to digital conversion unaffected by other functions. However, the clock (resonator or external input) must be supplied to XIN even when slave mode is set.
- In slave mode, the sampling frequency operates at 8kHz to 96kHz.
- The master clock operates at 512fs or 256fs.
- Slave mode and the master clock are set with the MPSEL[1:0] register.
- In slave mode, the following functions are assigned to MPIO[4:1].
  - MPIO1: ADC master clock (512fs or 256fs) input pin
  - MPIO2: ADC bit clock (64fs) input pin
  - MPIO3: ADC channel clock (fs) input pin
  - MPIO4: ADC audio data output pin

Table 9.3 Clocks That Can Be Input to MPIO[3:1] in Slave Mode

Pin Name	MPIO1	MPIO2	MPIO3
Usage	Master clock	Bit clock	LR clock
Input clock	512fs or 256fs	64fs	fs
Input clock range	2.048MHz to 24.576MHz	512kHz to 6.144MHz	8kHz to 96kHz

- In slave mode, the ADC clocks output from MCKOUT, BCKOUT, LRCKOUT and MPOUT[3:1] are the signals input to MPIO[3:1]. The system doesn't operate normally when there is no clock input to MPIO[3:1]. Therefore, must be supply the clock to MPIO[3:1] in slave mode.
- The data that has been analog to digital converted according to the DAFORM register setting is output from MPIO4 and MPOUT4. These output data are not affected by MUTEb.

## 9.3 Digital HPF

- The ADC incorporates a digital HPF to cancel the DC offset.
- The HPF cutoff frequency is 1.85Hz when  $f_s=48\text{kHz}$ . The frequency response is proportional to  $f_s$ .

## 9.4 PGA

- The LC89075WA incorporates an analog PGA (Programmable Gain Amplifier).
- The PGA can be set to -4.5dB to +6dB in 1.5dB steps with the ADPGA[2:0] register.
- The input impedance is  $27\text{k}\Omega$ , and the ADC full-scale input is proportional to the  $AV_{DD}$  voltage.  $V_{IN}=0.6 \times AV_{DD}$

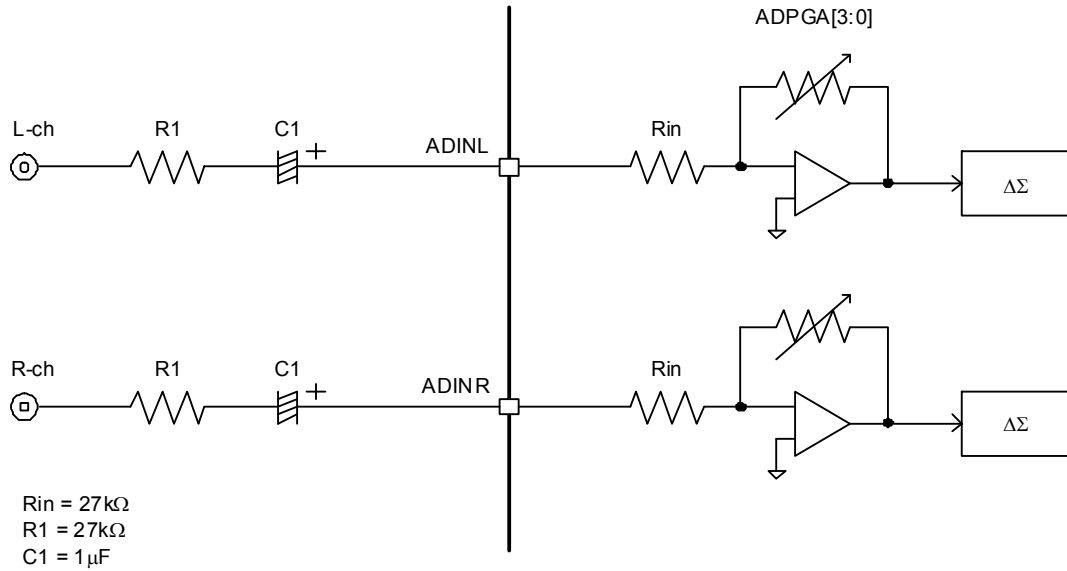

$$f_c = 1/(2\pi(R_{in}+R1)C1) = 1/(2\pi \times (27\text{k}+27\text{k}) \times 1\mu) = 2.947\text{Hz}$$

$$Z_i = R_{in}+R1 = 27\text{k}+27\text{k} = 54\text{k}\Omega$$

Figure 9.2 Internal PGA Analog Input Configuration Diagram

9.5 Soft Mute/Attenuator

- The LC89075WA incorporates a digital volume that can adjust from 0dB to -63.5dB and  $-\infty$ dB.
- The digital volume is set with the ADVOL[7:0] register. When the ADVOL[7:0] register setting is changed, the volume changes according to the ADFDSP[2:0] register setting. The volume changes the gain in 0.25dB steps.
- When “ADSMUTE=1”, soft mute operation is performed to attenuate the volume from the ADVOL[7:0] register setting value to -63.5dB according to the ADFDSP[2:0] register setting, and then to  $-\infty$ dB (0 data). The gain changes in 0.25dB steps during soft mute operation.
- When mute is canceled during mute execution, the process is stopped and the gain returns to 0dB in 0.25dB steps.
- When mute is set again during mute canceled, the cancel process is stopped and the mute process is performed to  $-\infty$ dB.

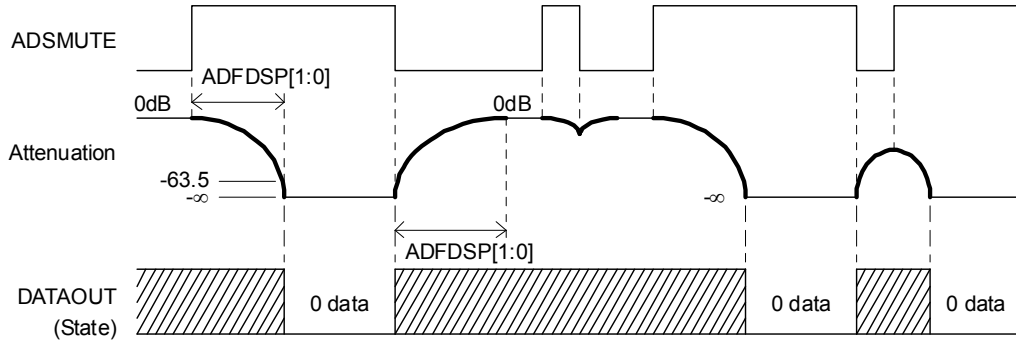

Figure 9.3 Soft Mute Timing Chart

Table 9.4 ADC Output Volume Gain Settings

ADVOL [7:0]	Gain [dB]
00h	0 (initial value)
01h	-0.25
02h	-0.50
03h-FDh	•••
FEh	-63.5
FFh	$-\infty$

Table 9.5 ADC Output Volume Fade Slope Settings

ADFDSP[2:0]	Fade Slope	0dB to $-\infty$ dB Transition Time (Reference)*1
000	1/fs (initial value)	256/fs
001	2/fs	512/fs
010	4/fs	1024/fs
011	8/fs	2048/fs
100	16/fs	4096/fs
101	Reserved	-
110	Reserved	-
111	Direct	1/fs

\*1: The time required to attenuate from 0dB to  $-\infty$ dB when “ADVOL[7:0]=00h”.

9.6 Analog Audio Data Detection (DSTATE)

- The LC89075WA can detect the existence ('Sound' or 'Silence') of analog audio data. 'Sound' has the audio data above threshold level. 'Silence' has the audio data below threshold level.
- The 'Sound' detection can be performed in normal operation mode or low sampling rate operation mode.
- The 'Silence' detection can be performed in normal operation mode.
- These detections can be performed on the analog data while the ADC is operating. They cannot be performed while the ADC is in the reset or the power-down status.

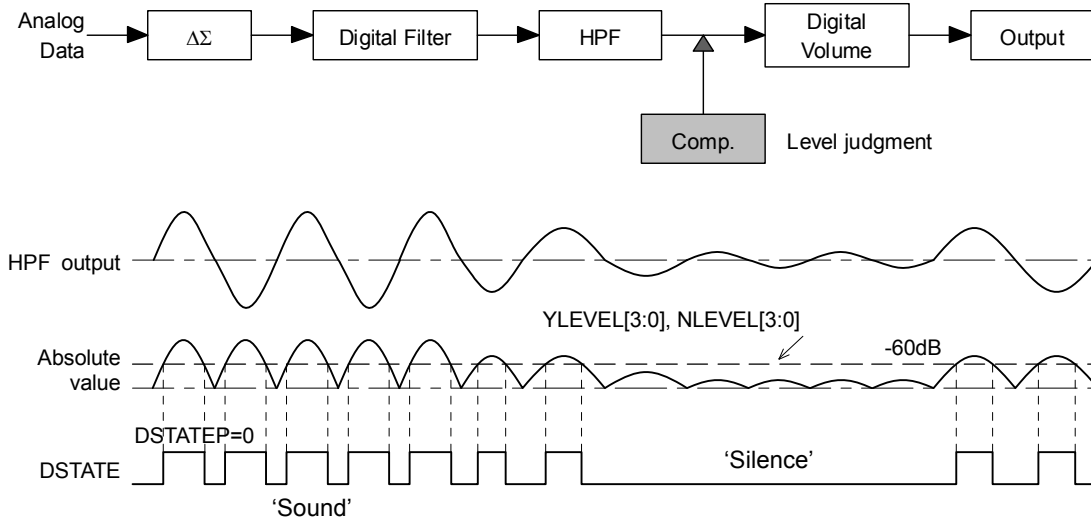

Figure 9.4 Analog Audio Data Detection Timing

9.6.1 'Sound' Detection

9.6.1.1 Detection in Normal Operation Mode

- To perform detection in normal operation mode, "SDMODE=1" is set.
- Analog to digital conversion is performed at a sampling frequency of 48kHz or 96kHz in master mode, or at the clock frequency input to MPIO[3:1] in slave mode.

9.6.1.2 Detection in Low Sampling Rate Operation Mode

- Low sampling rate operation mode can be used only when set to master mode. (See section 9.1.3)
- To perform detection in low sampling rate operation mode, "SDMODE=1" and "ADCOPR[1:0]=10" must be set.
- In this mode, analog to digital conversion is performed at a sampling frequency of 6kHz.
- In this operation mode, the following register settings are recommended to reduce current consumption other than by the ADC.

Table 9.6 Recommended Register Settings for the ADC Power Save Mode Operation

Adr	Register Name	Register Description	Recommended Value	Remarks
00h	ADCOPR[1:0]	ADC operation setting	10	Power save mode operation
00h	DIROPR	DIR operation setting	1	Stop
01h	SDMODE	Analog or digital audio data detection setting	1	'Sound' detection
02h	XMSEL[1:0]	XMCK pin output setting	11	"L" output
05h	OUTMUT	Clock and data output setting	1	"L" output
06h	SW2SEL[2:0]	MPOUT[4:1] pin output setting	000	"L" output
0Bh	RXTHR1[3:0]	RXOUT output data setting	1111	"L" output
0Bh	RXDSEL[3:0]	DIR data demodulation input setting	1111	Connected to GND
0Ch	RXTHR2[3:0]	MPOUT4 output data setting	1111	"L" output

9.6.1.3 Threshold and Output

- The ‘Sound’ threshold level is set with YLEVEL[3:0] register.
- The YLEVEL[3:0] register can adjust the level from -60dBFS to -30dBFS in 2dBFS steps.
- At YLEVEL[3:0] register initial value, ‘Sound’ is judged when the signal is larger than -60dBFS.
- The results of judging the data after passing through the HPF are output from DSTATE pin and ODATAM register.
- When a signal that is larger than the threshold level set by YLEVEL[3:0] register is detected, DSTATE outputs “H.”

9.6.2 ‘Silence’ Detection

- The ‘Silence’ detection operates in normal operation mode, and “SDMODE=0” is set.
- The ‘Silence’ threshold level is set with NLEVEL[3:0] register.
- The NLEVEL[3:0] register can adjust the level from -60dBFS to -30dBFS in 2dBFS steps.
- At NLEVEL[3:0] register initial value, ‘Silence’ is judged when the signal is smaller than -60dBFS.
- The results of judging the data after passing through the HPF are output from DSTATE pin and ODATAM register.
- When a signal that is smaller than the threshold level set by NLEVEL[3:0] register is detected, DSTATE outputs “L.”

9.6.3 DSTATE Output

- The DSTATE output polarity can be changed with DSTATEP.
- The DSTATE pin status can also be read from ODATAM register.
- When ADC operation is stopped, DSTATE outputs “L.”

Table 9.7 Analog Data and DSTATE Pin Output Status (When “DSTATEP=0”)

DSTATE Output	SDMODE=0 (‘Silence’ detection)	SDMODE=1 (‘Sound’ detection)
L	Smaller than the value set by the NLEVEL register or the ADC is reset	Smaller than the value set by the YLEVEL register or the ADC is reset
H	Larger than the value set by the NLEVEL register	Larger than the value set by the YLEVEL register

- ‘Sound’ or ‘Silence’ detection can be performed for digital audio data in addition to analog audio data. See below for further details, “12. Digital Audio Data Detection”.

9.7 Reset Process

- When the PLL is locked by setting “SYSRST=1” or “ADCOPR[1:0]=00”, the ADC is in the reset status. When “ADBMOD=0” is set, 16384/fs period is normally necessary for the reset cancel. If “ADBMOD=1” is set, it has not wait time. The digital data is output after fade-in processing after reset cancel.
- ‘Sound’ or ‘Silence’ detection flag DSTATE after reset cancel is output after progress 32768/fs.

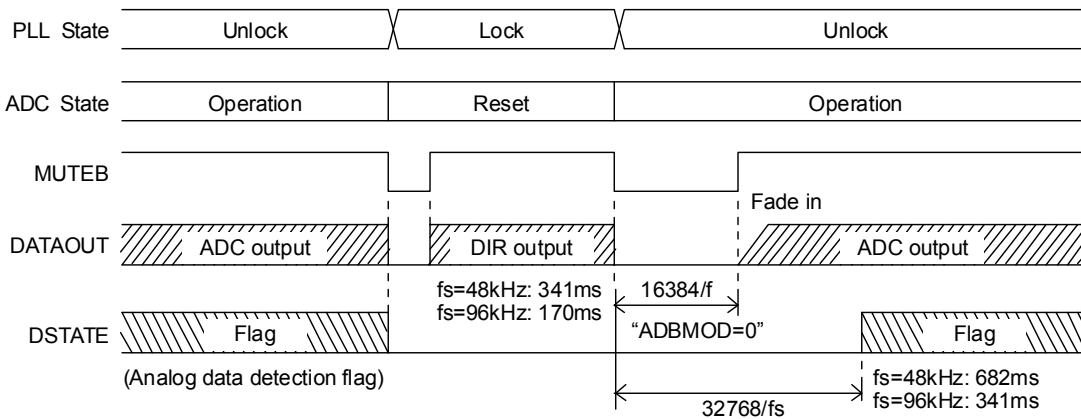

Figure 9.5 ADC Reset Processing Timing (When “ADBMOD=0”)

## 10. Description of Digital Audio Interface Receiver (DIR)

### 10.1 Clocks

- When the PLL is unlocked, the DIR operates at the clock input to XIN. When the PLL is locked, the DIR operates at the internal VCO (PLL) clock.

#### 10.1.1 PLL Source Master Clock

- The PLL synchronizes with the input S/PDIF and outputs a 512fs clock.
- The PLL clock is controlled by the RXCKAT, RXCKDV[1:0] and RXMCK[1:0] register settings.
- Normally, “RXCKAT=0” is set and a PLL clock is output for each input sampling frequency band. At this setting, output clock frequency fluctuation by varying the sampling frequency is kept to a narrow band, such as 512fs output when fs=32kHz to 48kHz, 256fs output when fs=64kHz to 96kHz, and 128fs output when fs=128kHz to 192kHz.
- When “RXCKAT=0” is set, the PLL clock is set by the RXCKDV[1:0] register
- To set an output clock that does not depend on the S/PDIF input sampling frequency, “RXCKAT=1” is set. At this setting, the clock frequency is always multiplied by a constant and output, such as output at 256fs for all sampling frequencies from 32kHz to 192kHz.
- When “RXCKAT=1” is set, the PLL clock is set by the RXMCK[1:0] register.
- When the PLL is locked, switching is not performed even when the RXCKAT, RXCKDV[1:0] and RXMCK[1:0] registers setting are changed. These registers switching are executed when the PLL is in unlocked status. This setting becomes valid after the PLL is locked again. And, only when "RXCKAT=1" is set, RXMCK[1:0] register can be changed by setting "RXCKMU=1" even PLL lock state. However, the change is not reflected in MUTE<sub>B</sub>.
- The PLL output clock setting flow is shown below. Note that the PLL can be stopped with the DIOPR register.

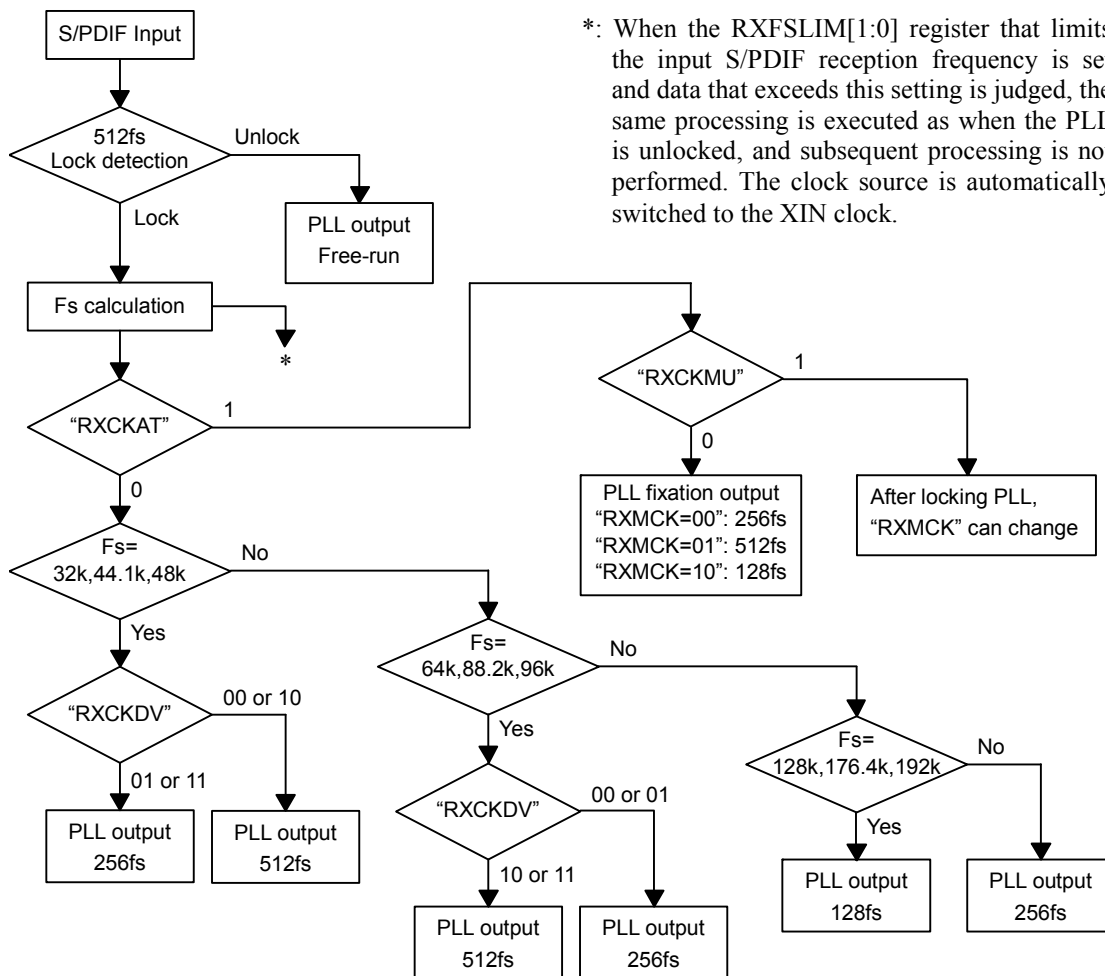

Figure 10.1 PLL Output Clock Flow Diagram



- The PLL clock output frequencies are shown below.
- When “RXCKAT=1” and “RXMCK[1:0]=01” are set (512fs), 128kHz, 176.4kHz and 192kHz S/PDIF reception results in a PLL output frequency that exceeds 50MHz, so direct output to MCKOUT is not guaranteed.

Table 10.2 PLL Clock Output Frequencies (Bold settings are initial values.)

S/PDIF fs (kHz)	PLL Output (MHz)						
	“RXCKAT=0” (Fixed multiple outputs for each input fs band)				“RXCKAT=1” (Fixed multiple outputs of input fs)		
	“RXCKDV=00”	“RXCKDV=01”	“RXCKDV=10”	“RXCKDV=11”	“RXMCK=00” (256fs)	“RXMCK=01” (512fs)	“RXMCK=10” (128fs)
32	<b>16.38</b>	8.19	16.38	8.19	8.19	16.38	4.09
44.1	<b>22.57</b>	11.28	22.57	11.28	11.28	22.57	5.64
48	<b>24.57</b>	12.28	24.57	12.28	12.28	24.57	6.14
64	<b>16.38</b>	16.38	32.76	32.76	16.38	32.76	8.19
88.2	<b>22.57</b>	22.57	45.15	45.15	22.57	45.15	11.28
96	<b>24.57</b>	24.57	49.15	49.15	24.57	49.15	12.28
128	<b>16.38</b>	16.38	16.38	16.38	32.76	65.54 *	16.38
176.4	<b>22.57</b>	22.57	22.57	22.57	45.15	90.32 *	22.57
192	<b>24.57</b>	24.57	24.57	24.57	49.15	98.30 *	24.57

\*: Direct output to the MCKOUT pin is not guaranteed.

### 10.1.2 XIN Source Master Clock (XIN, XOUT, XMCK)

- The DIR uses clock supply to XIN for the following applications.
  - 1) Clock source when the PLL is unlocked
  - 2) PLL lock-in support
  - 3) Calculation of the input data sampling frequency
- A clock must always be supplied to XIN.
- Normally, the oscillation amplifier always operates regardless of the PLL status, but operation that automatically stops the oscillation amplifier while the PLL is locked can also be set. This is set by the AMPOPR[1:0] register. The AMPOPR[1:0] register must be set before S/PDIF input, or the setting must be completed while the PLL is unlocked. In addition, when the oscillation amplifier is automatically stopped, the XMCK clock is not output.
- When “SW1SEL[2:0]=001”, “SW2SEL[2:0]=001” or slave mode “MPSEL[1:0]=10 or 11”, the oscillation amplifier is set to continuous operation mode. This has higher priority than the AMPOPR[1:0] register setting.

10.1.3 DIR Clock System Diagram (XIN, XOUT, XMCK)

- The relationship between the two types of master clock (PLL source, XIN source) and the switching and frequency division functions is shown below.
- The characters noted with quotation marks near the switches and function blocks correspond to the write register names.
- Lock/unlock is switched automatically according to the PLL locked/unlocked status.

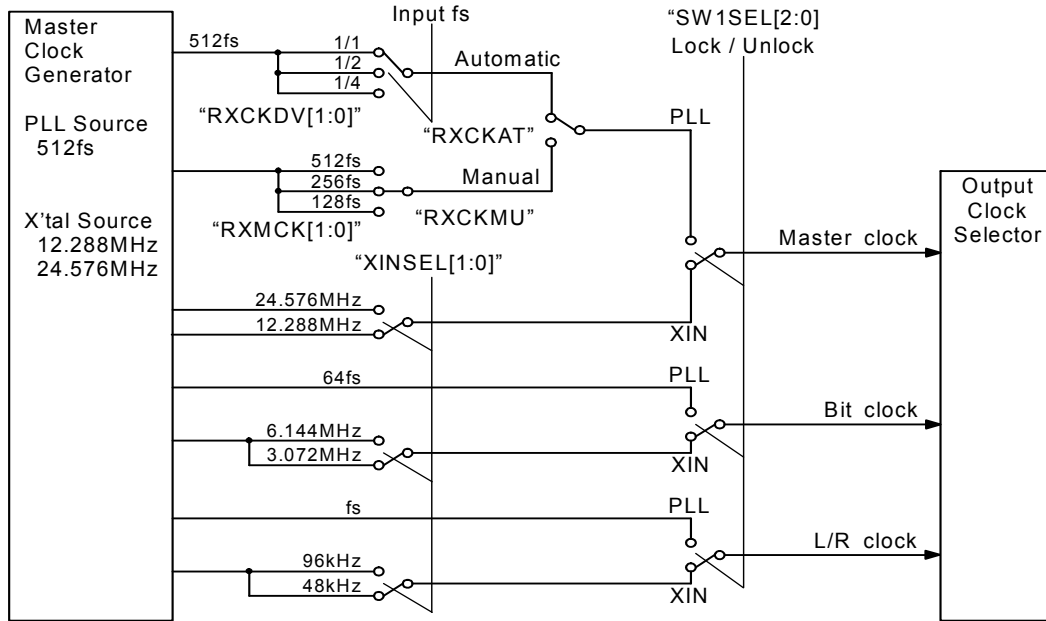

Figure 10.2 Clock Output System Diagram

- The clocks output from the DIR block are input to the output selector and output to MCKOUT, BCKOUT and LRCKOUT.

Table 10.3 DIR Output Clock Frequency Table

DIR Output The characters in parenthesis are output pins.	Source Clock (XIN) When PLL Is Unlocked		Source Clock (PLL) When PLL Is Locked
	12.288MHz	24.576MHz	512fs
Master clock (MCKOUT)	12.288MHz	24.576MHz 12.288MHz	512fs 256fs 128fs
Bit clock (BCKOUT)	6.144MHz 3.072MHz		64fs
L/R clock (LRCKOUT)	96kHz 48kHz		fs

10.1.4 Mute Signal Output During the Clock Switching Period (MUTEB)

- MUTEB outputs a pulse when the output clocks change due to the PLL locked/unlocked status.
- The MUTEB pulse output polarity can be changed with the DIRMUTP register. The description below assumes that DIRMUTP is 0.
- In the lock-in process, after input data is detected, MUTEB falls at the word clock generated from the XIN clock after the PLL is locked, and then rises at the same timing as ERRF once a certain period of time has passed.
- In the unlock process, MUTEB falls at the same timing as the PLL lock detection signal ERRF, and then rises after the word clock generated from the XIN clock is counted for a certain number of times.
- Changes in the PLL locked status and the timing of clock changes can be seen by detecting the MUTEB pulse and rising and falling edges.
- The clocks switch after the PLL lock judgment, and this switching timing can be set with the RXCKWT[1:0] register. At the initial setting, the clocks switch approximately 2.7ms after MUTEB falls. However, this value depends on the condition that the oscillation amplifier is set to the constantly operating status. When set so that the oscillation amplifier stops after the PLL is locked, the start-up time required until the oscillation amplifier stabilizes after the PLL is unlocked is added to the value.
- The clock output pins output free-running clocks immediately after the PLL is unlocked.
- In the unlock process, MUTEB is changed by ADBMOD register. See below for further details, “14. Microcontroller Interface”.

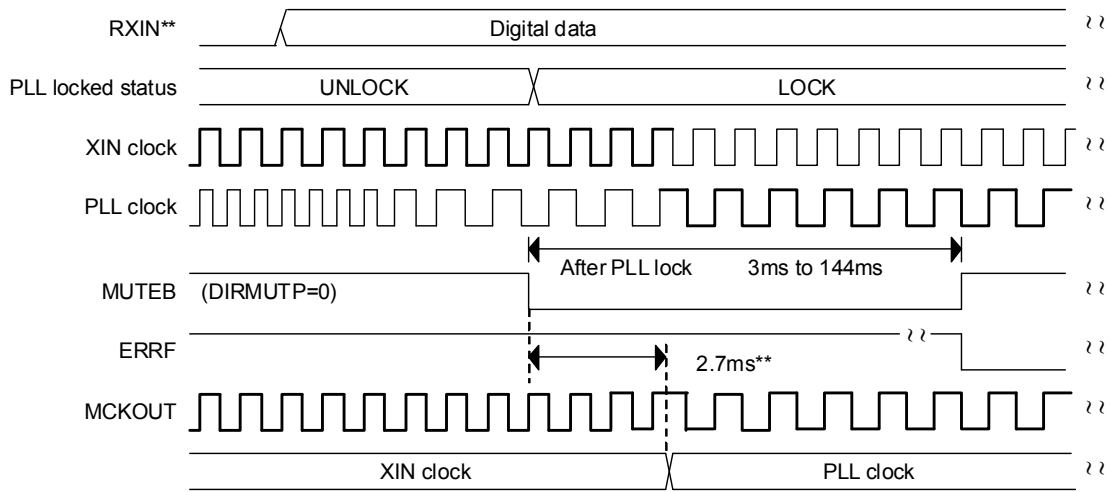

(a) Lock-in stage

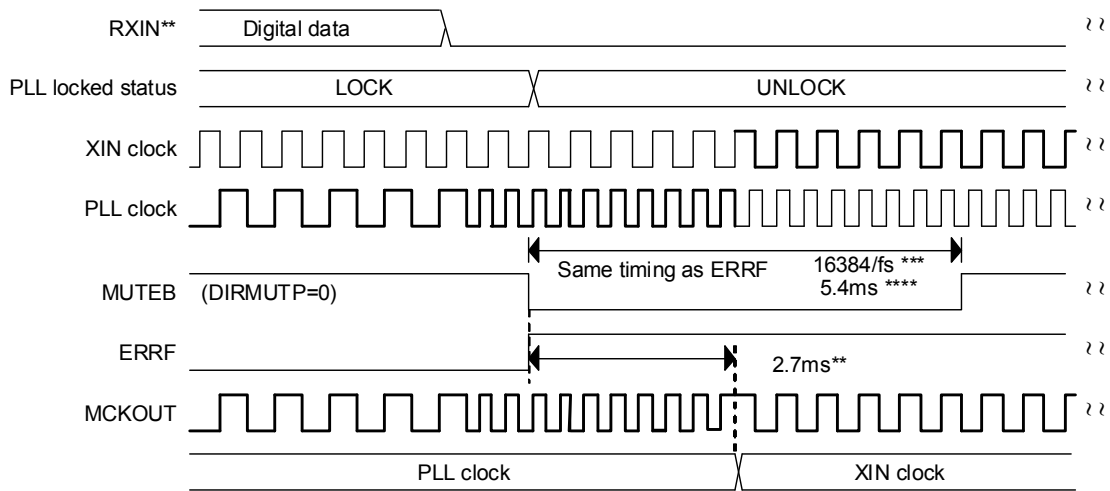

(b) Unlock stage

\*\* : When set to "RXCKWT[1:0]=00"  
 \*\*\* : When set to "ADBMOD=0"  
 \*\*\*\* : When set to "ADBMOD=1"

Figure 10.3 Clock Switching Timing

10.1.5 Output Clocks Generated When Input S/PDIF Reception is Limited

- The input S/PDIF reception range can be set with the RXLIM[1:0] register.
- If an S/PDIF input that exceeds the reception range limit is supplied, the same processing is performed as when the PLL is unlocked. The clock source is then switched to the XIN clock, and clocks are output from respective clock pins.

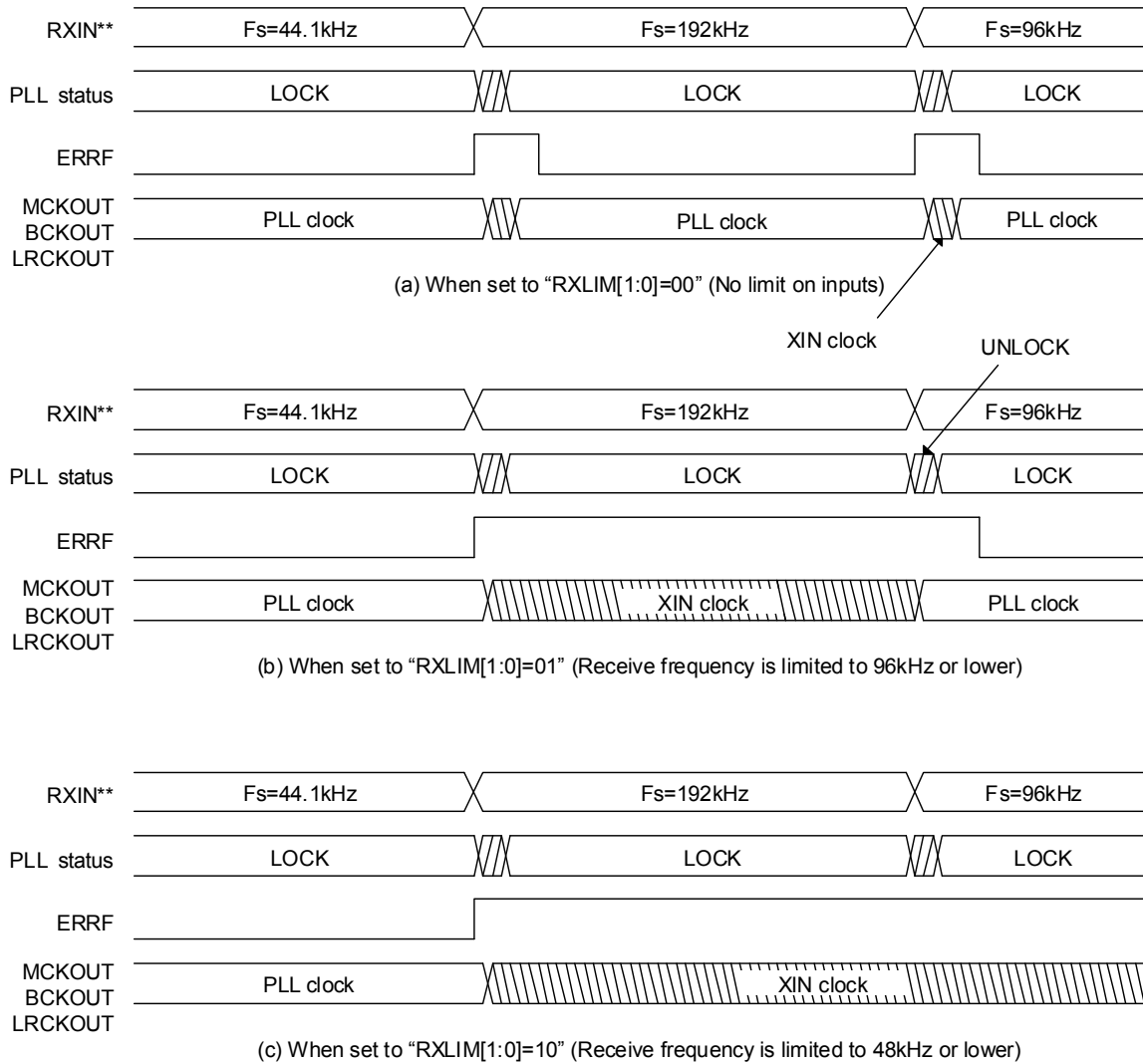

Figure 10.4 Output Clocks Generated When Input Data Reception Is Limited

## 10.2 S/PDIF Input/Output

### 10.2.1 S/PDIF Input Reception Range

- The input data reception range is shown below.

Table 10.4 S/PDIF Reception Range (“RXLIM[1:0]=00”)

PLL Output Clock Setting	Input Data Reception Range
512fs	32kHz to 192kHz

- The PLL output clock is output to each pin according to the RXCKAT, RXCKDV[1:0] and RXMCK[1:0] register settings.
- The fs reception range of input data can be limited to within the above PLL output clock setting range. This setting is carried out with the RXLIM[1:0] register. When this function is used, input data exceeding the set range is considered as an error, and the clock source is automatically switched to the XIN source.

### 10.2.2 S/PDIF Input/Output Pins (RXIN1 to RXIN8, RXIN1A to RXIN3A, MPIO[4:1], RXOUT, MPOUT4)

- Up to 15 digital data input pins are provided. In addition, two S/PDIF output pins are provided.
- RXIN[8:1] pins are TTL level compatible input pins with 5V tolerance voltage.
- MPIO[4:1] are TTL level compatible input pins with 3.3V tolerance voltage.
- MPIO[4:1] must be set to input with the MPSEL[1:0] register.
- RXIN[3:1]A are TTL level with 3.3V tolerance voltage or coaxial compatible input pins.
- Each RXIN[3:1]A change the function by the RX1ASEL, RX2ASEL and RX3ASEL registers.
- In the initial status, RXIN[3:1]A are set to TTL level compatible input pins.
- When RXIN[3:1]A are used for coaxial input, RXIN[3:1]A must connect terminator and DC cutting capacity.
- All the S/PDIF input pins can receive 32kHz to 192kHz data.
- RXOUT and MPOUT4 are input selector output pins, and output the S/PDIF through data.
- The demodulated data and the through output data can be selected separately.
- The demodulated data is selected with the RXDSEL[3:0] register.
- The RXOUT pin output data is selected with the RXTHR1[3:0] register.
- The MPOUT4 pin output data is selected with the RXTHR2[3:0] register.
- The S/PDIF through data output from the MPOUT4 pin is set with the SW2SEL[2:0] register.
- The RXDSEL[3:0] register can also be set so that all input digital data is deselected. This enables input data switching via the no-signal input status.
- The RXTHR1[3:0] and RXTHR2[3:0] registers are initially set so that RXOUT and MPOUT4 output “L.”  
When not using RXOUT and MPOUT4, muting these pins is recommended.

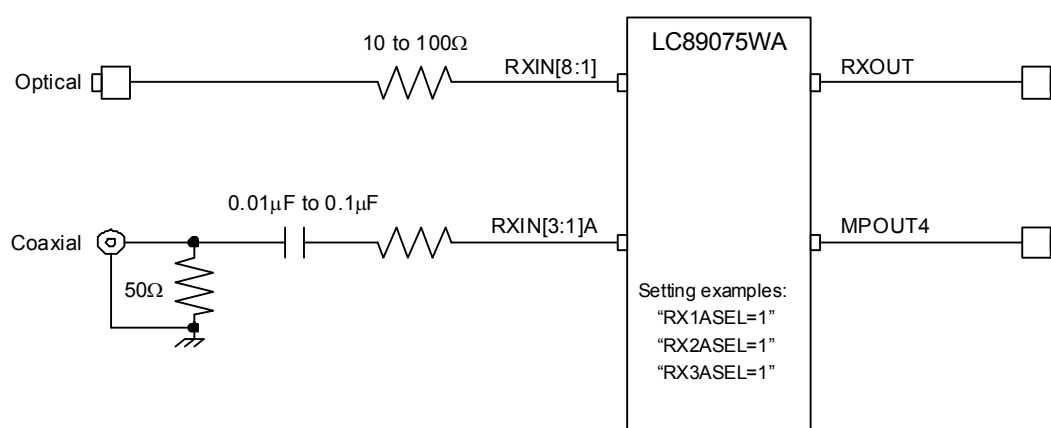
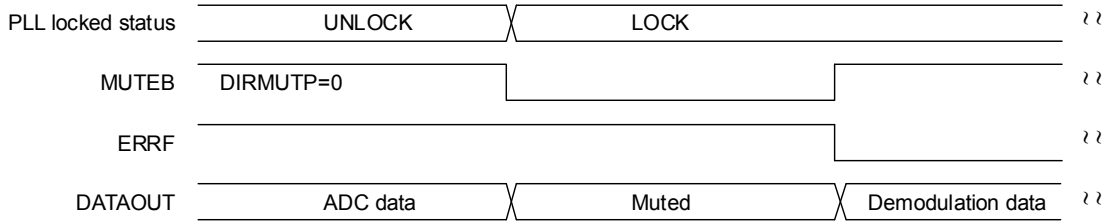

Figure 10.5 S/PDIF Input Circuit Example

10.3 Output Data Switching (DATAOUT)

- In the initial setting status, demodulated data is output to DATAOUT when the PLL is locked, and ADC data is output to DATAOUT when the PLL is unlocked. This output switching is performed automatically according to the PLL locked/unlocked status.



(a) Lock-in stage

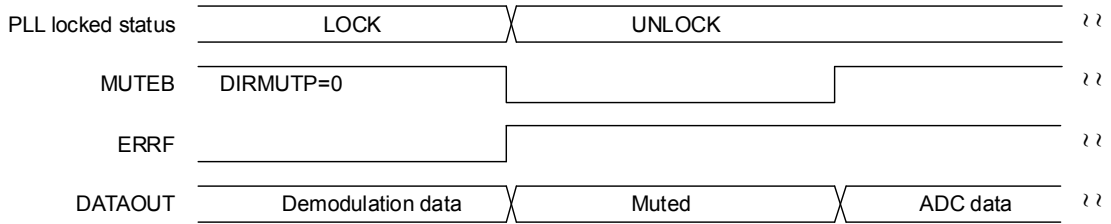

(b) Unlock stage

Figure 10.6 Timing Chart of DATAOUT Output Data Switching

## 10.4 Error Output Processing

### 10.4.1 Lock Error and Data Error Output (ERRF)

- ERRF outputs an error flag when a PLL lock error or a data error occurs.
- It is possible to treat non-PCM data reception as an error by setting up the RXRESEL register.
- The ERRF output conditions are set with the RXRESTA register.

### 10.4.2 PLL Lock Error

- The PLL gets unlocked for input data that lost bi-phase modulation regularity, or input data for which preambles B, M, and W cannot be detected.
- ERRF turns to "H" upon occurrence of a PLL lock error, and returns to "L" when data demodulation returns to normal and "H" is held for somewhere between 3ms to 144ms. This hold time is determined by the setting of the RXERWT[1:0] register.
- ERRF pulse output polarity can be changed with the DIRERRP register. However, although the DIRERRP register setup is reflected to ERRF output, it is not reflected to the read-out register OERROR.
- ERRF is output in synchronization with LRCKOUT.

### 10.4.3 Input Data Parity Error

- An odd number of errors among parity bits in input data and input parity errors are detected.
- If an input parity error occurs 9 or more times in succession, ERRF turns to "H" indicating that the PLL is locked, and after holding "H" for somewhere between 3ms to 144ms, it returns to "L."
- The error flag output format can be selected with the RXREDER register when an input parity error is output 8 or fewer times in succession.

### 10.4.4 Other Errors

- Even if ERRF turns to "L," the channel status bits of 24 to 27 (sampling frequency information) are always fetched and the data of the previous block is compared with the current data. Moreover, the input data sampling frequency is calculated from the fs clock extracted from the input data, and the fs calculated value is compared in the same way as described above. If any difference is detected in these data, ERRF is instantly made "H" and the same processing as for PLL lock errors is carried out. In this case, the clock source is switched to XIN and processing is restarted at lock status identification processing.
- In order to support sources with a variable fs (for example, a CD player with a variable pitch function), any change in fs made after ERRF is reset is not reflected on ERRF unless such change exceeds the PLL capture range.
- To have the change in fs made after the resetting of ERRF reflected on ERRF, set the "RXREFSJ=1".
- If a setting which regards non-PCM data input as an error is made with the RXRESEL register, ERRF turns to "H" when non-PCM data input is detected. At this time, the PLL locked status and respective output clocks are subject to the input data, but the output data is muted. The non-PCM data is the information that is output from NPCMF and subject to the NPSEL register setting.
- The PLL is set to the unlock state when the ADC clock and the data output have been selected by "SW1SEL[2:0]=001" and ERRF outputs the error flag.

10.4.6 Data Processing Upon Occurrence of Errors (Lock Error, Parity Error)

- The data processing upon occurrence of an error is described below. If 8 or fewer input parity errors occur in succession and transfer data is PCM audio data, the data is replaced by the one saved each in L-ch and R-ch in the previous frame. However, if the transfer data is non-PCM data, the error data is output as it is.
- Non-PCM data is the data of when bit 1 (non-PCM data detection bit) of the channel status turns to "H" based on the data detected prior to the occurrence of the input parity error.
- Output data is muted when a PLL lock error occurs or a parity error occurs 9 or more times in succession.
- As for the channel status data, the data of the previous block held in 1-bit units is output when a parity error occurs 8 or fewer times in succession.

Table 10.5 Data Processing upon Error Occurrence

Data	PLL Lock Error	Input Parity Error (a)	Input Parity Error (b)	Input Parity Error (c)
Demodulation data	"L"	"L"	Previous value data	Output
fs calculation result	Out of range	Output	Output	Output
Channel status	"L"	"L"	Previous value data	Previous value data

Input parity error (a): If occurs 9 or more times in succession

Input parity error (b): If occurs 8 or fewer times in succession in case of audio data

Input parity error (c): If occurs 8 or fewer times in succession in case of non-PCM burst data

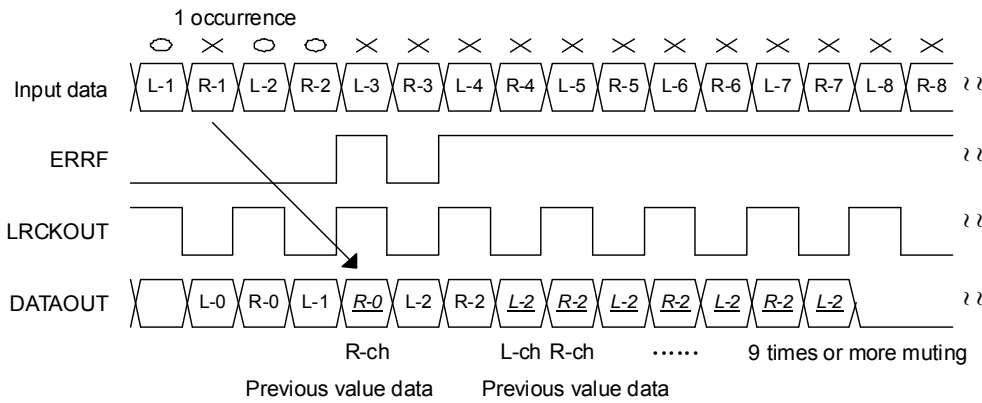
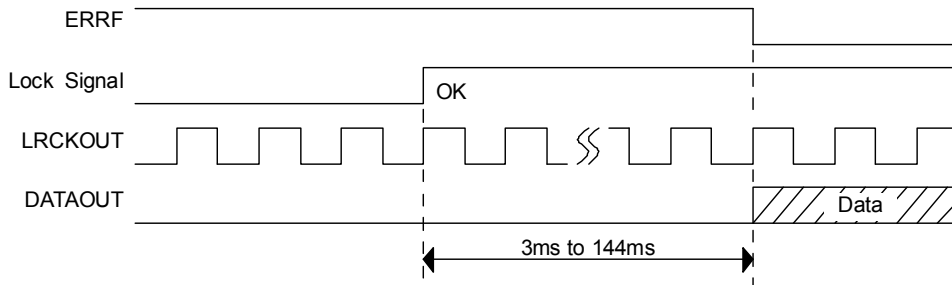

Figure 10.7 Example of Data Processing upon Parity Error Occurrence

10.4.7 Processing During Error Recovery

- When preambles B, M, and W are detected, the PLL becomes locked and data demodulation begins.
- The demodulation data is output from the LRCKOUT edge after ERRF turns to "L."



Output starts from LRCKOUT edge immediately after ERRF is lowered.

Figure 10.8 Data Processing When Data Demodulation Starts



## 10.5 Data Delimiter Bit 1 Output (NPCMF)

- NPCMF outputs the channel status data delimiter bit information.
- NPCMF outputs bit 1 of the channel status that indicates whether the input bi-phase data is PCM audio data. NPCMF is immediately output upon detection of ERRF even during the “H” output period.
- The IEC61937 and the DTS-CD detection flags can be output to NPCMF according to the NPSEL register.

Table 10.6 NPCMF Output

NPCMF	Output Conditions
L	PCM audio data (bit 1 = “L”)
H	Non-PCM audio data (bit 1 = “H”)

## 10.6 IEC61937 and DTS-CD Detection Flag Output

- A function to output IEC61937 and DTS-CD detection flags for non-PCM data are provided.
- When bit 1 of the channel status is non-PCM data, the IEC61937 sync signal is detected and detection flag is output. If bit 1 is PCM data, detection flag is not output.
- The DTS-CD detection is compatible with “14-bit format” and it is done based on the sync pattern and the base frequency. The sync pattern is checked every 4096th frame, and the detection status is held until the sync pattern is no longer verified.
- The IEC61937 and DTS-CD detection flags can be readout with the microcontroller interface in addition to output to NPCMF by the NPSEL register. When the UNPCM register of non-PCM signal output setting is selected through the INTB output contents setting, an interrupt signal is output from INTB detecting an IEC61937 or DTS-CD sync signal. This information is used to read out the output register and identify the details of the non-PCM signal.
- The detection flags are cleared when fs changes or when a PLL lock error or data error occurs.

## 10.7 Calculation of digital input data sampling frequency

- The input data sampling frequency is calculated using the XIN clock.
- If the oscillation amplifier is in a continuous operation mode, calculation is repeated constantly. Even if sampling changes within the PLL capture range for input data whose channel status sampling information does not change, the calculation results that follow the input data can be read.
- In the mode where the oscillation amplifier automatically stops according to the lock status of the PLL, the input data sampling frequency is calculated during the ERRF error period and completed when the oscillation amplifier stops with holding the value. Therefore, the value remains unchanged until the PLL becomes unlocked.
- The calculation results can be readout with the microcontroller interface. (RXFSC[3:0] register readout)
- The input data sampling frequency calculation value and channel status fs information are compared and if the sampling frequency is a same deal, “1” is read from the RXFSFLG register.

11. Description of Input/Output Audio Selector

- The LC89075WA incorporates a peripheral circuit audio selector.
- The audio selector can select the following configurations.
  - 1) 2-channel data support (4-line input ×6, 4-line output ×2)
  - 2) 6-channel data and 2-channel data support (6-line input ×1, 4-line input ×5, 6-line output ×1)
  - 3) 8-channel data and 2-channel data support (7-line input ×1, 4-line input ×4, 7-line output ×1)

11.1 2-channel Data Support

(Input pins: MCKIN, BCKIN, LRCKIN, DATAIN, MPIN[4:1], MPIO[4:1], RXIN[8:5])

(Output pins: MCKOUT, BCKOUT, LRCKOUT, DATAOUT, MPOUT[4:1], MUTEB, NPCMF)

- This selector configuration can process six systems of 2-channel data. The output can use two separate systems.
- The selector output is set with the MUXMOD, SW1SEL[2:0] and SW2SEL[2:0] registers.
- Immediately after power-on, MCKOUT, BCKOUT, LRCKOUT and DATAOUT output the ADC or DIR block clocks and data according to the PLL status, and MPOUT[4:1] is set to “L” output.
- DATAOUT and MPOUT4 can be muted with the DATAMUT and MPO4MUT registers.
- The MPIN5 and MPIN6 input signals can be output from MUTEB and NPCMF with the FLGOUT register.
- DSD data I/O is also possible. However, mute processing cannot be performed for both DSD channels.

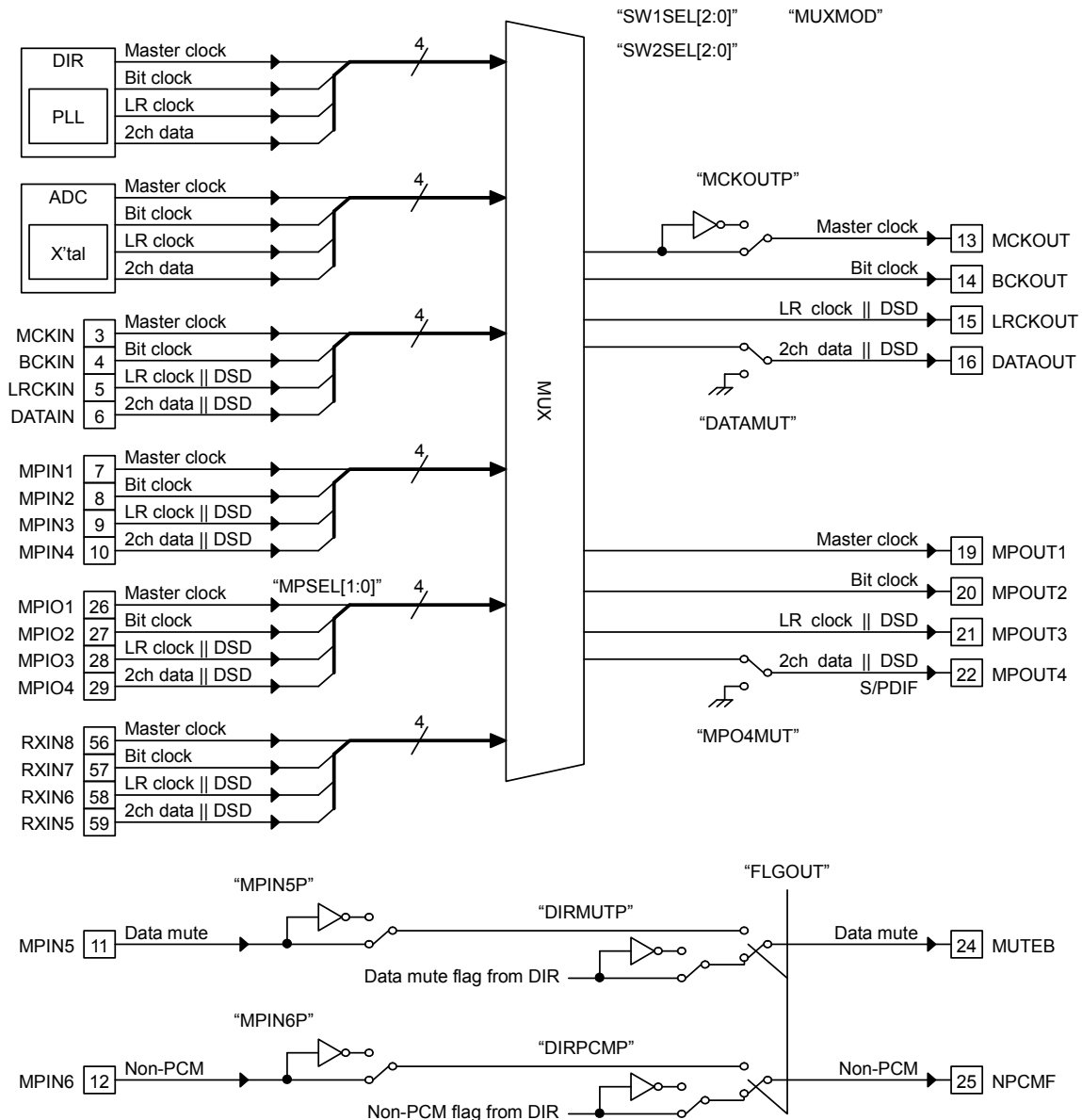

Figure 11.1 2-channel Data Support Audio Selector Configuration  
(Clock & Data MUX: 4-bits×6 inputs, 4-bits×2 outputs)

## LC89075WA

Table 11.1 Clock and Data Input/Output Configuration in 2-channel Data Selector Setting  
(MCKOUT, BCKOUT, LRCKOUT, and DATAOUT output pins)

SW1SEL Register	Selector Input	Selector Output	I/O Contents
000	DIR-MCK →	MCKOUT (13)	Master clock output
	DIR-BCK →	BCKOUT (14)	Bit clock output
	DIR-LRCK →	LRCKOUT (15)	LR clock output
	DIR-DATA →	DATAOUT (16)	2ch data output
000 001	ADC-MCK →	MCKOUT (13)	Master clock output
	ADC-BCK →	BCKOUT (14)	Bit clock output
	ADC-LRCK →	LRCKOUT (15)	LR clock output
	ADC-DATA →	DATAOUT (16)	2ch data output
010	MCKIN (3) →	MCKOUT (13)	Master clock input/output
	BCKIN (4) →	BCKOUT (14)	Bit clock input/output
	LRCKIN (5) →	LRCKOUT (15)	LR clock or DSD data input/output
	DATAIN (6) →	DATAOUT (16)	2ch data or DSD data input/output
011	MPIN1 (7) →	MCKOUT (13)	Master clock input/output
	MPIN2 (8) →	BCKOUT (14)	Bit clock input/output
	MPIN3 (9) →	LRCKOUT (15)	LR clock or DSD data input/output
	MPIN4 (10) →	DATAOUT (16)	2ch data or DSD data input/output
100 ("MPSEL[1:0]=01")	MPIO1 (26) →	MCKOUT (13)	Master clock input/output
	MPIO2 (27) →	BCKOUT (14)	Bit clock input/output
	MPIO3 (28) →	LRCKOUT (15)	LR clock or DSD data input/output
	MPIO4 (29) →	DATAOUT (16)	2ch data or DSD data input/output
101	RXIN8 (56) →	MCKOUT (13)	Master clock input/output
	RXIN7 (57) →	BCKOUT (14)	Bit clock input/output
	RXIN6 (58) →	LRCKOUT (15)	LR clock or DSD data input/output
	RXIN5 (59) →	DATAOUT (16)	2ch data or DSD data input/output
110 111 (Mute output)	-	MCKOUT (13)	"L" output
		BCKOUT (14)	"L" output
		LRCKOUT (15)	"L" output
		DATAOUT (16)	"L" output

- The format of the audio data input to DATAIN, MPIN4, MPIO4 and RXIN5 should match the ADC and DIR output data format (DAFORM register setting).

## LC89075WA

Table 11.2 Clock and Data Input/Output Configuration in 2-channel Data Selector Setting  
(MPOUT1, MPOUT2, MPOUT3, and MPOUT4 output pins)

SW2SEL Register	Selector Input	Selector Output	I/O Contents
000 (Mute output)	-	MPOUT1 (19)	"L" output
		MPOUT2 (20)	"L" output
		MPOUT3 (21)	"L" output
	S/PDIF input →	MPOUT4 (22)	Input S/PDIF select output
001	ADC-MCK →	MPOUT1 (19)	Master clock output
	ADC-BCK →	MPOUT2 (20)	Bit clock output
	ADC-LRCK →	MPOUT3 (21)	LR clock output
	ADC-DATA →	MPOUT4 (22)	2ch data output
010	MCKIN (3) →	MPOUT1 (19)	Master clock input/output
	BCKIN (4) →	MPOUT2 (20)	Bit clock input/output
	LRCKIN (5) →	MPOUT3 (21)	LR clock or DSD data input/output
	DATAIN (6) →	MPOUT4 (22)	2ch data or DSD data input/output
011	MPIN1 (7) →	MPOUT1 (19)	Master clock input/output
	MPIN2 (8) →	MPOUT2 (20)	Bit clock input/output
	MPIN3 (9) →	MPOUT3 (21)	LR clock or DSD data input/output
	MPIN4 (10) →	MPOUT4 (22)	2ch data or DSD data input/output
100 ("MPSEL[1:0]=01")	MPIO1 (26) →	MPOUT1 (19)	Master clock input/output
	MPIO2 (27) →	MPOUT2 (20)	Bit clock input/output
	MPIO3 (28) →	MPOUT3 (21)	LR clock or DSD data input/output
	MPIO4 (29) →	MPOUT4 (22)	2ch data or DSD data input/output
101	RXIN8 (56) →	MPOUT1 (19)	Master clock input/output
	RXIN7 (57) →	MPOUT2 (20)	Bit clock input/output
	RXIN6 (58) →	MPOUT3 (21)	LR clock or DSD data input/output
	RXIN5 (59) →	MPOUT4 (22)	2ch data or DSD data input/output
110	For 6ch data process (See 11.2)		
111	For 8ch data process (See 11.3)		

- The format of the audio data input to DATAIN, MPIN4, MPIO4 and RXIN5 should match the ADC and DIR output data format (DAFORM register setting).
- The DIR demodulated data and clocks are not output from MPOUT[4:1].

Table 11.3 External Flag Input/Output Configuration in 2-channel Data Selector Setting  
(MUTEB and NPCMF output pins)

FLGOUT Register	Selector Input	Selector Output	I/O Contents
1	MPIN5 (11) →	MUTEB (24)	Mute flag
	MPIN6 (12) →	NPCMF (25)	Non-PCM flag

11.2 6-channel Data and 2-channel Data Support

(Input pins: MCKIN, BCKIN, LRCKIN, DATAIN, MPIN[6:1], MPIO[4:1], RXIN[8:5])

(Output pins: MCKOUT, BCKOUT, LRCKOUT, DATAOUT, MPOUT[2:1])

- This selector configuration can process one system of 6-channel data and five systems of 2-channel data.
- The selector output is set with the MUXMOD, SW1SEL[2:0] and SW2SEL[2:0] registers.
- The 2-channel data is output from DATAOUT. This output can be muted with the DATAMUT register.
- The 6-channel data is output from DATAOUT and MPOUT[2:1]. This output can be muted with the D6CHMUT register.
- The S/PDIF signal can be output from MPOUT4. This is set with the RXTHR2[3:0] register.
- DSD data I/O is also possible. However, mute processing cannot be performed for both DSD channels.

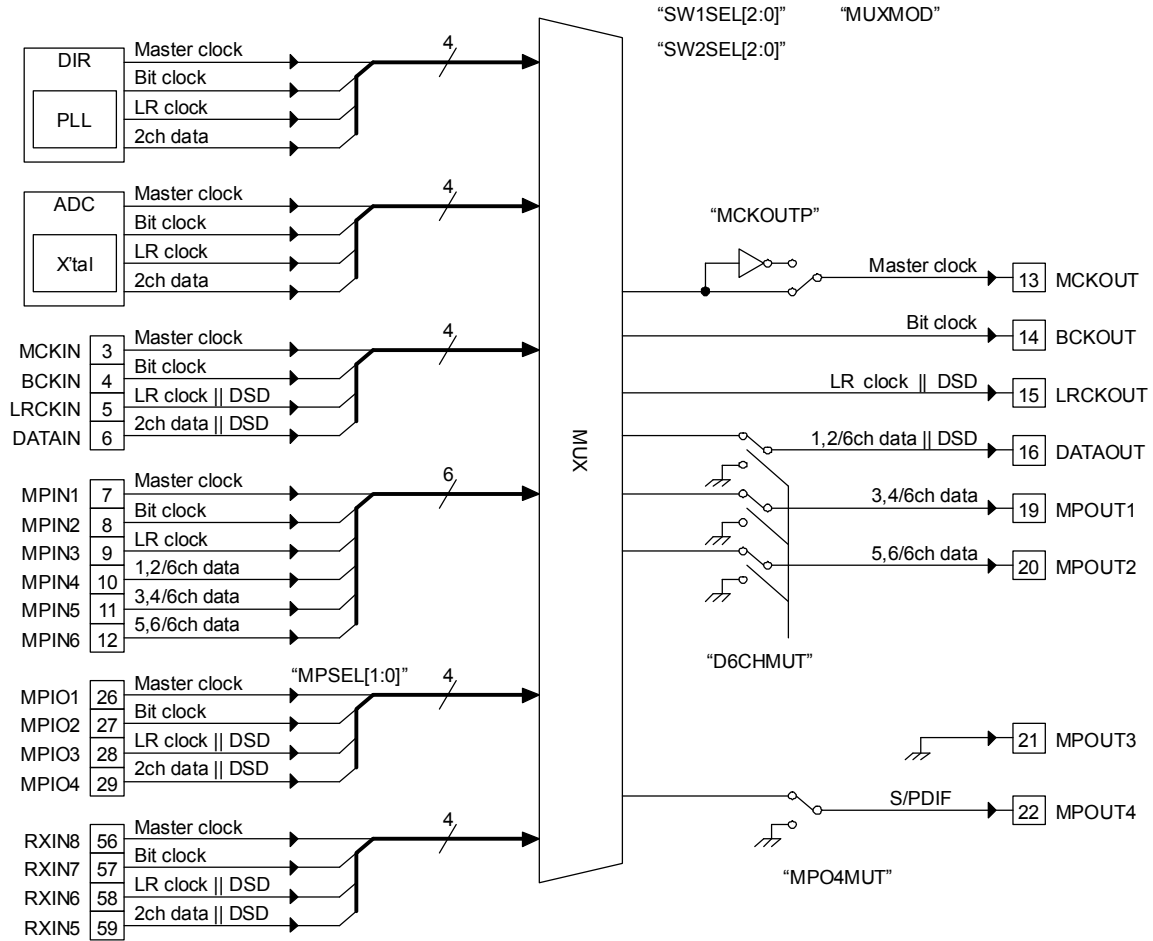

Figure 11.2 6-channel Data and 2-channel Data Support Audio Selector Configuration  
(Clock & Data MUX: 6-bits×1 input, 4-bits×5 inputs, 6-bits×1 output)

Table 11.4 Clock and Data Input/Output Configuration in 6-channel Data Selector Setting  
(MCKOUT, BCKOUT, LRCKOUT, DATAOUT and MPOUT[4:1] output pins)

SW1SEL Register	SW2SEL Register	Selector Input	Selector Output	I/O Contents
011	110	MPIN1 (7) →	MCKOUT (13)	Master clock input/output
		MPIN2 (8) →	BCKOUT (14)	Bit clock input/output
		MPIN3 (9) →	LRCKOUT (15)	LR clock input/output
		MPIN4 (10) →	DATAOUT (16)	1, 2/6ch data input/output
		MPIN5 (11) →	MPOUT1 (19)	3, 4/6ch data input/output
		MPIN6 (12) →	MPOUT2 (20)	5, 6/6ch data input/output
		-	MPOUT3 (21)	"L" output
		S/PDIF input →	MPOUT4 (22)	Input S/PDIF select output

## LC89075WA

- The format of the audio data input to MPIN4, MPIN5 and MPIN6 should match the ADC and DIR output data format (DAFORM register setting).
- In the 6-channel data selector configuration, MPOUT3 is fixed to “L” output and the MPOUT4 output is subject to the RXTHR2 register setting.

Table 11.5 Clock and Data Input/Output Configuration When Switching from 6-channel to 2-channel  
(MCKOUT, BCKOUT, LRCKOUT, and DATAOUT output pins)

SW1SEL Register	Selector Input	Selector Output	I/O Contents
000	DIR-MCK →	MCKOUT (13)	Master clock output
	DIR-BCK →	BCKOUT (14)	Bit clock output
	DIR-LRCK →	LRCKOUT (15)	LR clock output
	DIR-DATA →	DATAOUT (16)	2ch data output
000 001	ADC-MCK →	MCKOUT (13)	Master clock output
	ADC-BCK →	BCKOUT (14)	Bit clock output
	ADC-LRCK →	LRCKOUT (15)	LR clock output
	ADC-DATA →	DATAOUT (16)	2ch data output
010	MCKIN (3) →	MCKOUT (13)	Master clock input/output
	BCKIN (4) →	BCKOUT (14)	Bit clock input/output
	LRCKIN (5) →	LRCKOUT (15)	LR clock or DSD data input/output
	DATAIN (6) →	DATAOUT (16)	2ch data or DSD data input/output
100 ("MPSEL[1:0]=01")	MPIO1 (26) →	MCKOUT (13)	Master clock input/output
	MPIO2 (27) →	BCKOUT (14)	Bit clock input/output
	MPIO3 (28) →	LRCKOUT (15)	LR clock or DSD data input/output
	MPIO4 (29) →	DATAOUT (16)	2ch data or DSD data input/output
101	RXIN8 (56) →	MCKOUT (13)	Master clock input/output
	RXIN7 (57) →	BCKOUT (14)	Bit clock input/output
	RXIN6 (58) →	LRCKOUT (15)	LR clock or DSD data input/output
	RXIN5 (59) →	DATAOUT (16)	2ch data or DSD data input/output
110 111 (Mute output)	-	MCKOUT (13)	"L" output
	-	BCKOUT (14)	"L" output
	-	LRCKOUT (15)	"L" output
	-	DATAOUT (16)	"L" output

- The format of the audio data input to DATAIN, MPIO4 and RXIN5 should match the ADC and DIR output data format (DAFORM register setting).

11.3 8-channel Data and 2-channel Data Support

(Input pins: MCKIN, BCKIN, LRCKIN, DATAIN, MPIN[3:1], MPIN[6:4], MPIO[4:1], RXIN[8:5])

(Output pins: MCKOUT, BCKOUT, LRCKOUT, DATAOUT, MPOUT[4:1], ERRF, MUTEB, NPCMF)

- This selector configuration can process one system of 8-channel data and four systems of 2-channel data.
- The selector output is set with the MUXMOD, SW1SEL[2:0] and SW2SEL[2:0] registers.
- The 2-channel data is output from DATAOUT. This output can be muted with the DATAMUT register.
- The 8-channel data is output from DATAOUT and MPOUT[3:1]. This output can be muted with the D8CHMUT register.
- The S/PDIF signal can be output from MPOUT4. This is set with the RXTHR2[3:0] register.
- ERRF, MUTEB and NPCMF can output the MPIN4, MPIN5 and MPIN6 input signals according to the FLGERR and FLGOUT register settings.
- DSD data I/O is also possible. However, mute processing cannot be performed for both DSD channels.

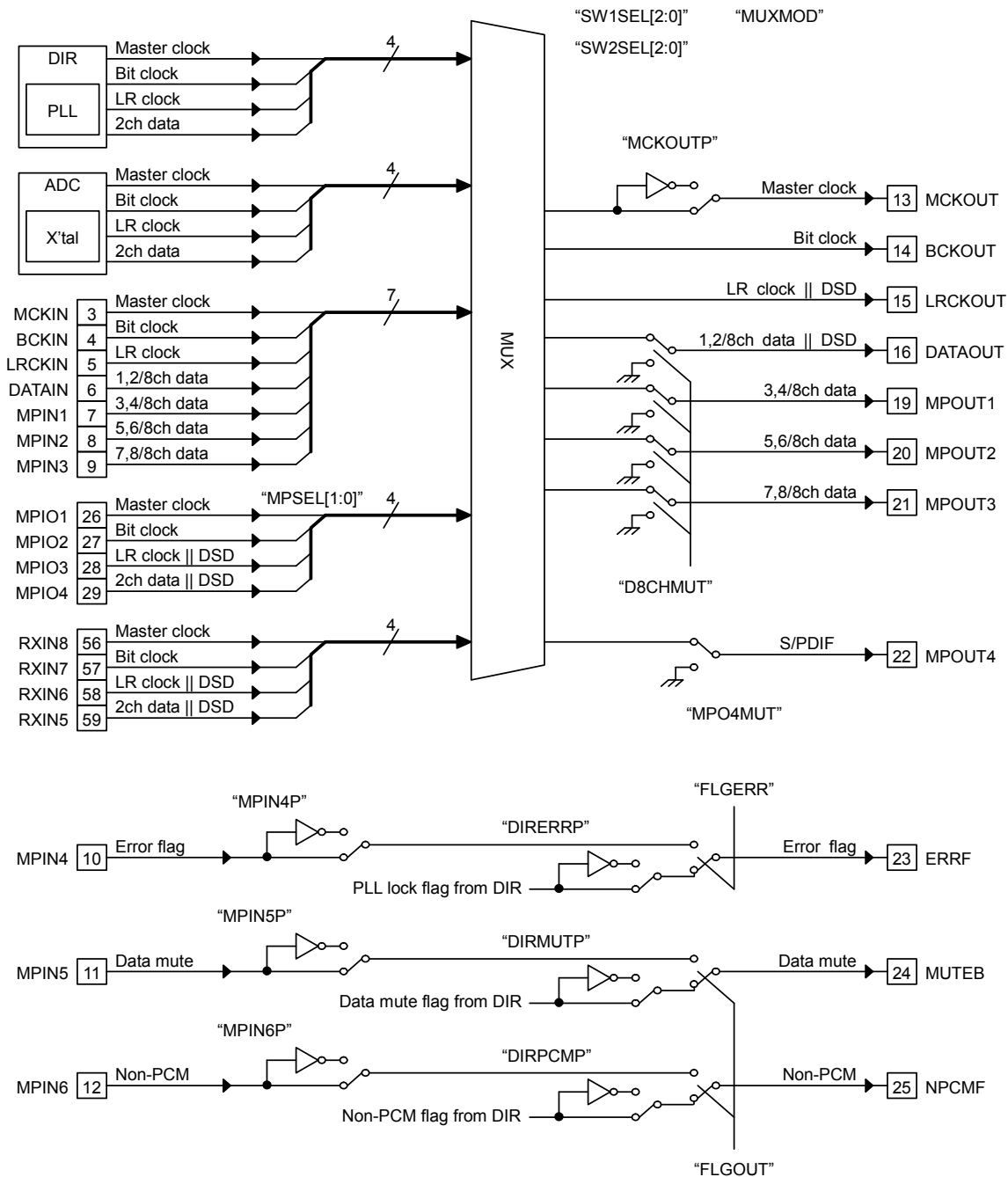

Figure 11.3 8-channel Data and 2-channel Data Support Audio Selector Configuration  
(Clock & Data MUX: 7-bits×1 input, 4-bits×4 inputs, 7-bits×1 output)

- In the 8-channel data selector configuration, the MPOUT4 output is subject to the RXTHR2 register setting.

## LC89075WA

Table 11.6 Clock and Data Input/Output Configuration in 8-channel Data Selector Setting  
(MCKOUT, BCKOUT, LRCKOUT, DATAOUT, and MPOUT[4:1] output pins)

SW1SEL Register	SW2SEL Register	Selector Input	Selector Output	I/O Contents
010	111	MCKIN (3) →	MCKOUT (13)	Master clock input/output
		BCKIN (4) →	BCKOUT (14)	Bit clock input/output
		LRCKIN (5) →	LRCKOUT (15)	LR clock input/output
		DATAIN (6) →	DATAOUT (16)	1, 2/8ch data input/output
		MPIN1 (7) →	MPOUT1 (19)	3, 4/8ch data input/output
		MPIN2 (8) →	MPOUT2 (20)	5, 6/8ch data input/output
		MPIN3 (9) →	MPOUT3 (21)	7, 8/8ch data input/output
		S/PDIF input →	MPOUT4 (22)	Input S/PDIF select output

- The format of the audio data input to DATAIN, MPIN1, MPIN2 and MPIN3 should match the ADC and DIR output data format (DAFORM register setting).

Table 11.7 Clock and Data Input/Output Configuration When Switching from 8-channel to 2-channel  
(MCKOUT, BCKOUT, LRCKOUT, and DATAOUT output pins)

SW1SEL Register	Selector Input	Selector Output	I/O Contents
000	DIR-MCK →	MCKOUT (13)	Master clock output
	DIR-BCK →	BCKOUT (14)	Bit clock output
	DIR-LRCK →	LRCKOUT (15)	LR clock output
	DIR-DATA →	DATAOUT (16)	2ch data output
000 001	ADC-MCK →	MCKOUT (13)	Master clock output
	ADC-BCK →	BCKOUT (14)	Bit clock output
	ADC-LRCK →	LRCKOUT (15)	LR clock output
	ADC-DATA →	DATAOUT (16)	2ch data output
100 ("MPSEL[1:0]=01")	MPIO1 (26) →	MCKOUT (13)	Master clock input/output
	MPIO2 (27) →	BCKOUT (14)	Bit clock input/output
	MPIO3 (28) →	LRCKOUT (15)	LR clock or DSD data input/output
	MPIO4 (29) →	DATAOUT (16)	2ch data or DSD data input/output
101	RXIN8 (56) →	MCKOUT (13)	Master clock input/output
	RXIN7 (57) →	BCKOUT (14)	Bit clock input/output
	RXIN6 (58) →	LRCKOUT (15)	LR clock or DSD data input/output
	RXIN5 (59) →	DATAOUT (16)	2ch data or DSD data input/output
110 111 (Mute output)	-	MCKOUT (13)	"L" output
	-	BCKOUT (14)	"L" output
	-	LRCKOUT (15)	"L" output
	-	DATAOUT (16)	"L" output

Table 11.8 External Flag Input/Output Configuration in 8-channel Data Selector Setting  
(ERRF, MUTEb, and NPCMF output pins)

FLGERR Register	FLGOUT Register	Selector Input	Selector Output	I/O Contents
1	×	MPIN4 (10) →	ERRF (23)	Error flag
×	1	MPIN5 (11) →	MUTEb (24)	Mute flag
		MPIN6 (12) →	NPCMF (25)	Non-PCM flag



- The initial status of each ERRF, MUTE<sub>B</sub> and NPCMF output is shown below.
- When the polarities differ from the externally supplied signals, the polarities can be changed with the MPIN<sub>4P</sub>, MPIN<sub>5P</sub> and MPIN<sub>6P</sub> registers or the DIRERRP, DIRMUTP and DIRPCMP registers.

Table 11.11 Initial Setting Status of the ERRF, MUTE<sub>B</sub>, and NPCMF Output Pins

Output	ERRF Pin “DIRERRP=0”	MUTE <sub>B</sub> Pin “DIRMUTP=0”	NPCMF Pin “DIRPCMP=0”
“L”	PLL lock error cancelled	Output data mute processing	PCM data output
“H”	PLL unlock state	Data output	Non-PCM data output

- The format of the audio data input to DATAIN, MPIN[3:1], MPIN[6:4] and MPIO<sub>4</sub> is subject to the DAFORM register setting. The initial value is I<sup>2</sup>S output format.

## 11.4 Clock and Data Switching and Mute Process

- Selector switching with the SW1SEL[2:0] and SW2SEL[2:0] registers is normally processed immediately after these registers are set, but this switching can be synchronized to LRCKOUT with the MUXMOD register. However, note that in this case the switching process cannot be performed when LRCKOUT is not output. In addition, the LR clock is not input in systems that handle DSD data, so the MUXMOD register must not be used with these systems.
- Output data mute is set with the DATAMUT, D6CHMUT and D8CHMUT registers. When these mute-setting registers are set, MUTE<sub>B</sub> is muted with the MUTREF register. However, at the initial setting, the DATAMUT, D6CHMUT and D8CHMUT register settings are not reflected. However, mute processing cannot be performed for both DSD channels.
- MUTE<sub>B</sub> is output according to changing DIR and ADC blocks. Therefore, when the selector is used, MUTE<sub>B</sub> is changed according to the state of DIR and ADC. To process the mute with MUTE<sub>B</sub> when the selector is used, the signal output to MUTE<sub>B</sub> is changed to MPIN<sub>5</sub>. However, when MPIN[6:1] is used for clock and 6ch data input, the mute signal cannot be output from MUTE<sub>B</sub>.

## 12. Digital Audio Data Detection

- In addition to analog audio data detection, the LC89075WA can also detect the existence of digital audio data (2-channel data only) that are output from DATAOUT. It is set by DSTASEL register. (“DSTASEL=1”)
- The DATAOUT audio data detection process differs for PCM data and non-PCM data. The data is delimited by the channel status bit 1 information, the DTS-CD non-PCM detection flag, and also the MPIN<sub>6</sub> input signal when “FLGOUT=1” is set. The ‘Sound’ or ‘Silence’ detection can be selected with the SDMODE register.
- The ‘Sound’ or ‘Silence’ detection for PCM data is the same as that for analog audio data. The judgment levels are set with the YLEVEL[3:0] and NLEVEL[3:0] registers. The output data format conforms to the UDFORM register. The detection results are output from the DSTATE pin and the ODATAM register.
- The ‘Sound’ or ‘Silence’ detection for non-PCM data is judged by whether the mute status (0 data) is established. The ‘Silence’ is detected when all 24-bit of channel data are 0 data, and the ‘Sound’ is detected in all other cases. When performing detection for non-PCM data, the YLEVEL[3:0] and NLEVEL[3:0] register settings are not reflected.
- The DSTATE output is delayed by 1/2 frame relative to the DATAOUT output data. Moreover, the audio data detection doesn’t operate when the output clock selected with SW1SEL[2:0] register has stopped. At this time, DSTATE is continuously output the result before and becomes wrong information. Therefore, do not select the source without the clock supply.
- The digital audio data detection does not support DSD data. Note that when “DSTASEL=1” is set and DSD data is output, DSTATE outputs incorrect results.

## 13. Microcontroller Register Output (Expanded Output)

- The serial data input from the microcontroller interface is converted to parallel data and output from MPIO[4:1] pins. This function operates when “MPSEL[1:0]=00” and “MPSTA[1:0]=11” are set.
- Set the data to be output to MPIO[4:1] pins in the PI[3:0] register (address 03h).
- The data written to the PI[3:0] register is output to MPIO[4:1] pins.

**14. Microcontroller Interface (CSB, SCK, SI, SO, INTB)**

- The LC89075WA is controlled via SPI (Serial Peripheral Interface, Modes 0 & 3).
- This interface consists of CSB: chip select, SCK: serial clock input, SI: data input, and SO: data output.
- SI consists of read/write (R/W), “0” data (2 bits), register address (A[4:0]), and control data (8 bits × n, [MSB:LSB]). R/W is written when “0”, or read when “1”.

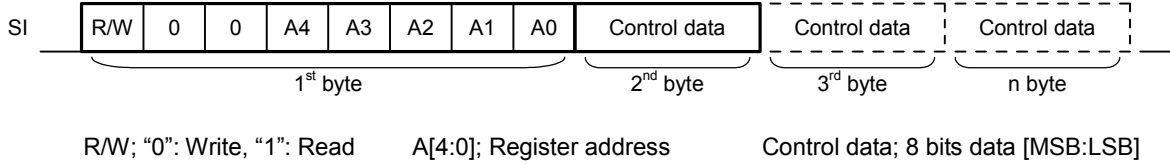

Figure 14.1 SI Input Data Format

- Data read is performed by R/W=1 and the data is output from SO after the register address is set.
- SO outputs high impedance when R/W=0 or when CSB is “H”.
- The LC89075WA incorporates an address counter, and is controlled in the current address access mode that performs read/write while automatically incrementing the address, or in the random address access mode that reads/writes the data for an arbitrary address.

**14.1 Current Address Access Mode**

- This mode holds the A[4:0] address value in the address counter for both read and write, and increments the address value by “+1” at the timing when D0 is loaded to the register. D[7:0] data write is executed at this same timing, and data write is performed in byte units thereafter (at the timing indicated by ↑ in Fig. 14.2).
- The increment function is executed while CSB is “L”, but when the write address exceeds 0Eh or the read address exceeds 17h, write stops and “0” data is output as the read data.

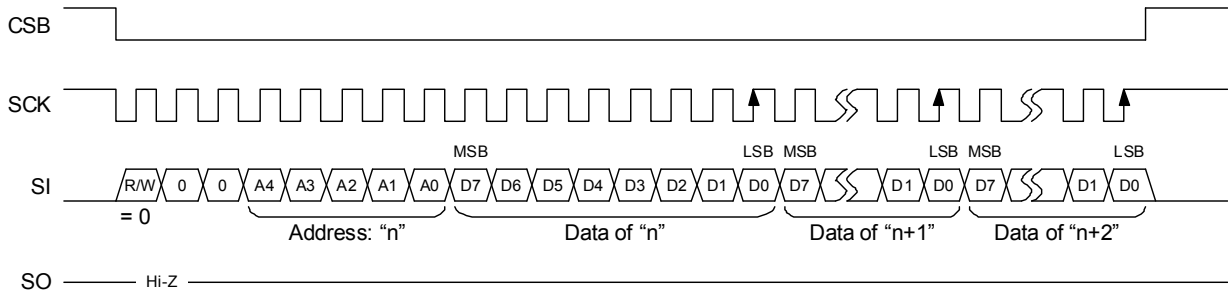

Figure 14.2 Current Address Access Mode Input Timing Chart

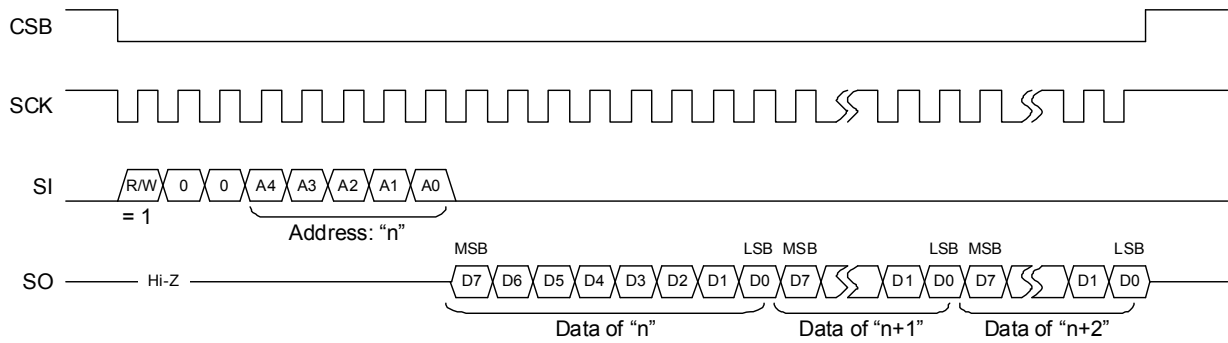

Figure 14.3 Current Address Access Mode Output Timing Chart

14.2 Random Address Access Mode

- Random address access mode reads and writes the data for an arbitrary address.
- A single address is processed for each command.
- The write data is loaded at the rising edge of the SCK immediately prior to the rising edge of CSB.
- A total of two bytes of address and data are executed for each input command, but when the SCK serial clock is input for 3 bytes or more, write is executed in the same manner as the previously described current address access mode. Note that in this case, the address is incremented and data is rewritten.
- Eight bits of data are read after the address setting for each output command. Like the input command, when SCK input continues while CSB is “L”, read is executed in the same manner as current address access mode.

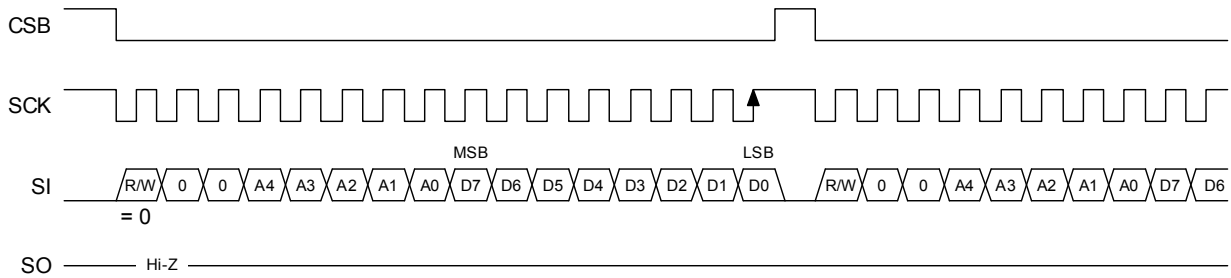

Figure 14.4 Random Address Access Mode Input Timing Diagram

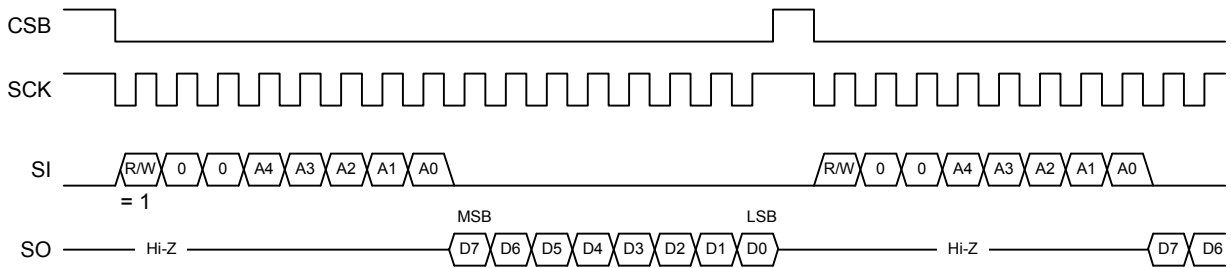

Figure 14.5 Random Address Access Mode Output Timing Diagram

14.3 Interrupt Output (INTB)

- Interrupts are output when a change has occurred in the PLL locked status or the output data information, etc.
- Interrupt output consists of the register for selecting the interrupt source, the INTB that outputs the state transition, and the registers that store the interrupt source data.
- When “INTBP=1” (initial value), INTB outputs “L” upon occurrence of an interrupt while “H” is output. Following this “L” output, INTB is cleared when the interrupt source output register is read, and returns to “H” output.
- The interrupt sources can be selected from among the following items. Multiple sources can be selected at the same time with the contents of address 0Eh. INTB outputs the OR calculation result of the selected interrupt sources.

INTB output = (Selected source 1) + (Selected source 2) + ... + (Selected source n)

Table 14.1 Interrupt Source Setting Contents

No.	Address 0Eh		Description
1	D0	ERROR	Output when ERRF pin status has changed.
2	D1	FSCHG	Output when input fs calculation result has changed.
3	D2	CSRNW	Output when channel status data of the first 40 bits has been updated.
4	D3	UNPCM	Output when NPCMF pin status has changed.
5	D4	PCRNW	Output when burst preamble Pc has been updated.
6	D5	EMPHA	Output when emphasis information has changed.
7	D7	DATAM	Output when DSTATE pin status has changed.

- The contents of the set interrupt sources are written in address 0Fh when the source occurs. However, when the contents of source items 1, 4 and 7 are read, the ERRF, NPCMF and DSTATE pin statuses are output, respectively.
- Source item 2 uses the oscillator amplifier clock, so when monitoring source item 2 even while the PLL is locked, the oscillation amplifier must be set to the continuous operation mode.
- INTB outputs “L” when a source occurs, and is cleared (“H”) immediately after address 0Fh read is set.
- INTB is not cleared other than when the reset process is performed with XMODE or the address 0Fh is set.

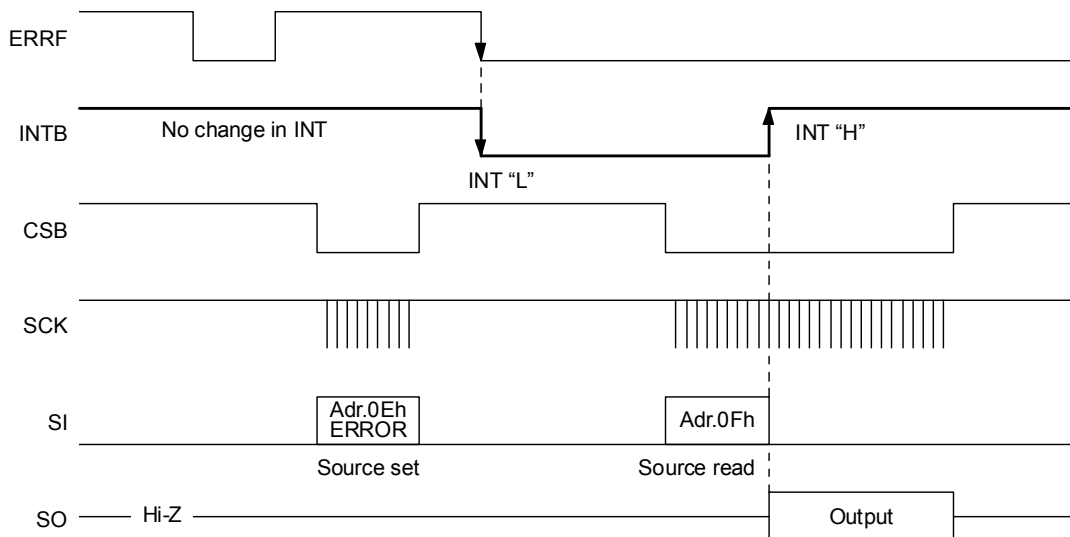

Figure 14.6 INTB Output Timing Example (when “INTBP=0”)

# LC89075WA

## 14.4 Registers

### 14.4.1 Register Map

Table 14.2 Register Map

Setting Item	R/W	Adr	D7	D6	D5	D4	D3	D2	D1	D0
System	R/W	00h	0	DIOPR	ADCOPR1	ADCOPR0	AMPOPR1	AMPOPR0	DAFORM	SYSRST
	R/W	01h	RXCKMU	INTBP	MCKOUTP	DSTATEP	0	0	DSTASEL	SDMODE
	R/W	02h	NPSEL	RX3ASEL	RX2ASEL	RX1ASEL	XMSEL1	XMSEL0	XINSEL1	XINSEL0
	R/W	03h	PI3	PI2	PI1	PI0	MPSTA1	MPSTA0	MPSEL1	MPSEL0
	R/W	04h	0	MPIN6P	MPIN5P	MPIN4P	0	DIRPCMP	DIRMUTP	DIRERRP
Selector	R/W	05h	0	OUTMUT	MUXMOD	MUTREF	MPO4MUT	D8CHMUT	D6CHMUT	DATAMUT
	R/W	06h	FLGOUT	SW2SEL2	SW2SEL1	SW2SEL0	FLGERR	SW1SEL2	SW1SEL1	SW1SEL0
	R/W	07h	NLEVEL3	NLEVEL2	NLEVEL1	NLEVEL0	YLEVEL3	YLEVEL2	YLEVEL1	YLEVEL0
ADC	R/W	08h	ADBMOD	ADPGA2	ADPGA1	ADPGA0	ADSMUTE	ADFDSP2	ADFDSP1	ADFDSP0
	R/W	09h	ADVOL7	ADVOL6	ADVOL5	ADVOL4	ADVOL3	ADVOL2	ADVOL1	ADVOL0
DIR	R/W	0Ah	RXCKWT1	RXCKWT0	RXMCK1	RXMCK0	RXCKDV1	RXCKDV0	0	RXCKAT
	R/W	0Bh	RXDSEL3	RXDSEL2	RXDSEL1	RXDSEL0	RXTHR13	RXTHR12	RXTHR11	RXTHR10
	R/W	0Ch	0	0	0	0	RXTHR23	RXTHR22	RXTHR21	RXTHR20
	R/W	0Dh	RXERWT1	RXERWT0	RXLIM1	RXLIM0	RXREFSJ	RXRESTA	RXREDER	RXRESEL
	R/W	0Eh	DATAM	0	EMPHA	PCRNW	UNPCM	CSRNW	FSCHG	ERROR
	R	0Fh	ODATAM	0	OEMPHA	OPCRNW	OUNPCM	OCSRNW	OFSCHG	OERROR
	R	10h	RXDTSSES	RXDTS51	RX61937	RXFSFLG	RXFSC3	RXFSC2	RXFSC1	RXFSC0
	R	11h	RXCS7	RXCS6	RXCS5	RXCS4	RXCS3	RXCS2	RXCS1	RXCS0
	R	12h	RXCS15	RXCS14	RXCS13	RXCS12	RXCS11	RXCS10	RXCS9	RXCS8
	R	13h	RXCS23	RXCS22	RXCS21	RXCS20	RXCS19	RXCS18	RXCS17	RXCS16
	R	14h	RXCS31	RXCS30	RXCS29	RXCS28	RXCS27	RXCS26	RXCS25	RXCS24
	R	15h	RXCS39	RXCS38	RXCS37	RXCS36	RXCS35	RXCS34	RXCS33	RXCS32
	R	16h	RXPC7	RXPC6	RXPC5	RXPC4	RXPC3	RXPC2	RXPC1	RXPC0
	R	17h	RXPC15	RXPC14	RXPC13	RXPC12	RXPC11	RXPC10	RXPC9	RXPC8

- “0” is a reserved bit. Always must be set to “0”.

## 14.4.2 Details of Registers

Address: 00h; System Setting (Setting of Various Functions)

00h	D7	D6	D5	D4	D3	D2	D1	D0
Register name	0	DIOPR	ADCOPR1	ADCOPR0	AMPOPR1	AMPOPR0	DAFORM	SYSRST
Initial value	0	0	0	0	0	0	0	0
Setting	R	R/W	R/W	R/W	R/W	R/W	R/W	R/W

**SYSRST**      System reset

- 0: Don't reset. (initial value)
- 1: Reset all circuits other than registers.

**DAFORM**      ADC and DIR audio data output format setting

- 0: I<sup>2</sup>S data output (initial value)
- 1: 24-bit MSB first, left-justified data output

**AMPOPR[1:0]**   Oscillation amplifier operation setting

- 00: Continuous operation (initial value)
- 01: Stop automatically when the PLL is locked. Operate when the PLL is unlocked.
- 10: Reserved
- 11: Stop

**ADCOPR[1:0]**   ADC operation setting

- 00: Reset stop when the PLL is locked. Operate when the PLL is unlocked (initial value).
- 01: Reserved
- 10: Low sampling rate operation (when "SDMODE=1")
- 11: Power down stop

**DIOPR**      DIR operation setting

- 0: Continuous operation (initial value)
- 1: Stop

- When "SYSRST=1" is set, the register settings are held and the circuits other than the registers are reset. However, the output clocks do not stop and the XIN clock is output.
- When either "SW1SEL[2:0]=001" or "SW2SEL[2:0]=001" is set, the oscillation amplifier is set to the continuous operation mode regardless of the "AMPOPR[1:0]" setting. However, when "AMPOPR[1:0]=11" is set, it is excluded.
- When "MPSEL[1:0]=10 or 11" is set or "SW1SEL[2:0]=001" and "SW2SEL[2:0]=001" are set, the ADC is set to the continuous operation mode regardless of the PLL status or the "AMPOPR[1:0]" setting.
- The ADC low sampling rate operation mode performs analog to digital conversion at 6kHz, and is set during analog audio data 'Sound' detection. The condition (required) for this mode is that "ADCOPR[1:0]=10" and "SDMODE=1" are set.
- When "DIOPR=1" is set while the PLL is locked, this setting is executed after the clock source is switched to XIN.

## LC89075WA

Address: 01h; System Setting ('Sound' or 'Silence' Detection Setting)

01h	D7	D6	D5	D4	D3	D2	D1	D0
Register name	RXCKMU	INTBP	MCKOUTP	DSTATEP	0	0	DSTASEL	SDMODE
Initial value	0	0	0	0	0	0	0	0
Setting	R/W	R/W	R/W	R/W	R	R	R/W	R/W

**SDMODE**      Digital data detection setting

0: Detect 'Silence' (initial value).

1: Detect 'Sound'

**DSTASEL**      DSTATE pin output setting

0: Output the result of 'Sound' or 'Silence' detection processing performed on the analog audio data (initial value).

1: Output the result of 'Sound' or 'Silence' detection processing performed on the digital audio data selected by the SW1SEL[2:0] register.

**DSTATEP**      DSTATE pin output polarity setting

0: Output "L" when reset or 'Silence' is detected. Output "H" when 'Sound' is detected (initial value).

1: Output "H" when reset or 'Silence' is detected. Output "L" when 'Sound' is detected.

**MCKOUTP**      MCKOUT pin output polarity setting

0: Output master clock to MCKOUT (initial value).

1: Invert the mater clock and output to MCKOUT.

**INTBP**          INTB pin output polarity setting

0: "H": No interrupt source present, "L": Interrupt source present (initial value)

1: "L": No interrupt source present, "H": Interrupt source present

**RXCKMU**      RXMCK[1:0] register setting when RXCKAT is set to 1

0: RXMCK[1:0] register can not be changed after PLL is locked (initial value).

1: RXMCK[1:0] register can be changed at any time.

- The 'Sound' and 'Silence' judgment levels can be adjusted separately with the SDMODE register and the YLEVEL[3:0] and NLEVEL[3:0] registers that set the detection level.
- When "DSTASEL=1" and analog audio data is selected (when "SW1SEL[2:0]=000" and the PLL is unlocked, or when "SW1SEL[2:0]=001"), the 'Sound' and 'Silence' detection is performed on the data before passing through the ADC output volume. In addition, when the non-PCM data flag is output from NPCMF, the judgment levels set by YLEVEL[2:0] and NLEVEL[2:0] are ignored, and 0 data detection is executed. When all 24-bit of data of each channel are "0", this is judged to be 'Silence' status, and "L" is output from DSTATE. Note that digital audio data 'Sound' and 'Silence' detection is not performed on the MPOUT[4:1] output (SW2SEL[2:0] register setting).
- Note that the detector circuit doesn't operate when the clock that is set "DSTASEL=1" and is selected by SW1SEL 2:0 register is not output from MCKOUT, BCKOUT, and LRCKOUT pins. Therefore, the DSTATE is not changed from the result before.

## LC89075WA

Address: 02h; System Setting (I/O Pin Setting 1)

02h	D7	D6	D5	D4	D3	D2	D1	D0
Register name	NPSEL	RX3ASEL	RX2ASEL	RX1ASEL	XMSEL1	XMSEL0	XINSEL1	XINSEL0
Initial value	0	0	0	0	0	0	0	0
Setting	R/W	R/W	R/W	R/W	R/W	R/W	R/W	R/W

**XINSEL[1:0]** Setting of the XIN pin input clock frequency, ADC control clock, and the output clock to be used when the ADC is selected.

- 00: XIN pin input clock = 12.288MHz (initial value)
  - ADC master clock: 12.288MHz      MCKOUT output clock: 12.288MHz
  - ADC bit clock: 3.072MHz          BCKOUT output clock: 3.072MHz
  - ADC channel clock: 48kHz          LRCKOUT output clock: 48kHz
- 01: XIN pin input clock = 24.576MHz
  - ADC master clock: 12.288MHz      MCKOUT output clock: 12.288MHz
  - ADC bit clock: 3.072MHz          BCKOUT output clock: 3.072MHz
  - ADC channel clock: 48kHz          LRCKOUT output clock: 48kHz
- 10: XIN pin input clock = 24.576MHz
  - ADC master clock: 12.288MHz      MCKOUT output clock: 24.576MHz
  - ADC bit clock: 3.072MHz          BCKOUT output clock: 3.072MHz
  - ADC channel clock: 48kHz          LRCKOUT output clock: 48kHz
- 11: XIN pin input clock = 24.576MHz
  - ADC master clock: 24.576MHz      MCKOUT output clock: 24.576MHz
  - ADC bit clock: 6.144MHz          BCKOUT output clock: 6.144MHz
  - ADC channel clock: 96kHz          LRCKOUT output clock: 96kHz

**XMSEL[1:0]** XMCK pin output setting

- 00: 1/1 of XIN pin input frequency output (initial value)
- 01: 1/2 of XIN pin input frequency output
- 10: 1/4 of XIN pin input frequency output
- 11: "L" output

**RX1ASEL** RXIN1A input function setting

- 0: TTL input level compatible input (initial value)
- 1: Coaxial input level compatible input

**RX2ASEL** RXIN2A input function setting

- 0: TTL input level compatible input (initial value)
- 1: Coaxial input level compatible input

**RX3ASEL** RXIN3A input function setting

- 0: TTL input level supported input (initial value)
- 1: Coaxial input level compatible input

**NPSEL** NPCMF pin output contents setting

- 0: Output only channel status, bit 1 (initial value).
- 1: Output channel status, bit 1, IEC61937, and DTS-CD detection flag.



# LC89075WA

Address: 03h; System Setting (I/O Pin Setting 2)

03h	D7	D6	D5	D4	D3	D2	D1	D0
Register name	PI3	PI2	PI1	PI0	MPSTA1	MPSTA0	MPSEL1	MPSEL0
Initial value	0	0	0	0	0	0	0	0
Setting	R/W	R/W	R/W	R/W	R/W	R/W	R/W	R/W

MPSEL[1:0] MPIO[4:1] pin I/O setting

- 00: All of the MPIO[4:1] pins are subject to the MPSTA[1:0] register setting (initial value).
- 01: All MPIO[4:1] pins are input.
- 10: ADC slave mode 512fs clock input (See 9.2.3, "Slave mode.")
- 11: ADC slave mode 256fs clock input (See 9.2.3, "Slave mode.")

MPSTA[1:0] MPIO[4:1] pin output setting when "MPSEL[1:0]=00" is set

- 00: MPIO1: Hi-Z output (initial value)  
MPIO2: Hi-Z output  
MPIO3: Hi-Z output  
MPIO4: Hi-Z output
- 01: MPIO1: Channel status, bit 1 output  
MPIO2: Channel status, copy bit output  
MPIO3: Channel status, pre-emphasis information output  
MPIO4: Channel status, L-bit output
- 10: MPIO1: PI0 output  
MPIO2: PI1 output  
MPIO3: PI2 output  
MPIO4: PI3 output
- 11: MPIO1: "L" output  
MPIO2: "L" output  
MPIO3: "L" output  
MPIO4: "L" output

PI0 MPIO1 output setting when "MPSEL[1:0]=00" and "MPSTA[1:0]=10"

- 0: "L" output (initial value)
- 1: "H" output

PI1 MPIO2 output setting when "MPSEL[1:0]=00" and "MPSTA[1:0]=10"

- 0: "L" output (initial value)
- 1: "H" output

PI2 MPIO3 output setting when "MPSEL[1:0]=00" and "MPSTA[1:0]=10"

- 0: "L" output (initial value)
- 1: "H" output

PI3 MPIO4 output setting when "MPSEL[1:0]=00" and "MPSTA[1:0]=10"

- 0: "L" output (initial value)
- 1: "H" output

- Switching to the MPIO[4:1] input setting ("MPSEL[1:0]=01") must be performed from the MPIO[4:1] high impedance output status.
- MPSTA[1:0] can be set only when "MPSEL[1:0]=00" is set.

## LC89075WA

Address: 04h; System Setting (Output Pin Polarity Setting)

04h	D7	D6	D5	D4	D3	D2	D1	D0
Register name	0	MPIN6P	MPIN5P	MPIN4P	0	DIRPCMP	DIRMUTP	DIRERRP
Initial value	0	0	0	0	0	0	0	0
Setting	R	R/W	R/W	R/W	R	R/W	R/W	R/W

**DIRERRP** Polarity setting of the error signal to be used when sending the DIR error flag to the ERRF pin  
 0: “H”: PLL lock error, “L”: PLL lock error cancel (initial value)  
 1: “L”: PLL lock error, “H”: PLL lock error cancel

**DIRMUTP** Polarity setting of the mute signal to be used when sending the DIR/ADC mute signal to the MUTE pin  
 0: “H”: Data output state, “L”: Data mute state (initial value)  
 1: “L”: Data output state, “H”: Data mute state

**DIRPCMP** Polarity setting of the data type signal to be used when sending the DIR data type signal to the NPCMF pin  
 0: “L”: PCM data, “H”: Non-PCM data (initial value)  
 1: “H”: PCM data, “L”: Non-PCM data

**MPIN4P** Polarity setting of MPIN4 to be used when sending the MPIN4 pin input signal to the ERRF pin (when “FLGERR=1” is set)  
 0: The MPIN4 input signal is output directly (initial value).  
 1: The MPIN4 input signal is inverted and output.

**MPIN5P** Polarity setting of MPIN5 to be used when sending the MPIN5 pin input signal to the MUTE pin (when “FLGOUT=1” is set)  
 0: The MPIN5 input signal is output directly (initial value).  
 1: The MPIN5 input signal is inverted and output.

**MPIN6P** Polarity setting of MPIN6 to be used when sending the MPIN6 pin input signal to the NPCMF pin (when “FLGOUT=1” is set)  
 0: The MPIN6 input signal is output directly (initial value).  
 1: The MPIN6 input signal is inverted and output.

- Adjust the MPIN4, MPIN5 and MPIN6 input signals with the MPIN4P, MPIN5P and MPIN6P registers so that the signals output from ERRF, MUTE pin and NPCMF match the DIRERRP, DIRMUTP and DIRPCMP register conditions.
- Although the DIRERRP register setup is reflected to ERRF output, it is not reflected to the read-out register OERROR.
- Although the DIRPCMP register setup is reflected to NPCMF output, it is not reflected to the read-out register OUNPCM.
- Non-PCM data is data detected according to the NPSEL register setting.

## LC89075WA

Address: 05h; Selector Setting (Output Mute Setting)

05h	D7	D6	D5	D4	D3	D2	D1	D0
Register name	0	OUTMUT	MUXMOD	MUTREF	MPO4MUT	D8CHMUT	D6CHMUT	DATAMUT
Initial value	0	0	0	0	0	0	0	0
Setting	R	R/W	R/W	R/W	R/W	R/W	R/W	R/W

- DATAMUT** DATAOUT pin output setting (2ch data output supported)  
 0: Data output (initial value)  
 1: Mute, “L” output
- D6CHMUT** DATAOUT, MPOUT1, and MPOUT2 pin output setting (6ch data output supported)  
 0: Data output (initial value)  
 1: Mute, “L” output
- D8CHMUT** DATAOUT, MPOUT1, MPOUT2, and MPOUT3 pin output setting (8ch data output supported)  
 0: Data output (initial value)  
 1: Mute, “L” output
- MPO4MUT** MPOUT4 pin output setting  
 0: Data output (initial value)  
 1: Mute, “L” output
- MUTREF** MUTE<sub>B</sub> pin output setting  
 0: The DATAMUT register is not reflected to MUTE<sub>B</sub> (initial value).  
 1: Place MUTE<sub>B</sub> in mute state when “DATAMUT=1” is set.
- MUXMOD** SW1SEL[2:0], FLGERR, SW2SEL[2:0], and FLGOUT register switching timing setting  
 0: Processed immediately after register is switched (initial value)  
 1: Processed in sync with LRCKOUT
- OUTMUT** MCKOUT, BCKOUT, LRCKOUT, and DATAOUT pins output setting (Power save operation support when ‘Sound’ is detected)  
 0: Clock and data output (initial value)  
 1: Mute, “L” output

- The DATAMUT, D6CHMUT, D8CHMUT and MUTREF registers are processed in sync with LRCKOUT.
- The MPO4MUT register is processed immediately after it is set.
- The MUTREF register setting outputs the data mute status in accordance with the DIRMUTP register setting.
- The D6CHMUT and D8CHMUT registers are not reflected to MUTE<sub>B</sub>.
- When “MUXMOD=1”, the SW1SEL[2:0], FLGERR, SW2SEL[2:0] and FLGOUT registers are switched at the rising edge of the LRCKOUT output. Note that the MUXMOD register must not be used when LR clock select the source without the LRCKOUT clock output or when DSD data is input, there is no LR clock input, to avoid the possibility of errors in operation.
- OUTMUT register is set, when the ‘Sound’ detection of analog or digital audio data is executed with low current consumption.

## LC89075WA

### Address: 06h; Selector Setting (Output Signal Setting)

06h	D7	D6	D5	D4	D3	D2	D1	D0
Register name	FLGOUT	SW2SEL2	SW2SEL1	SW2SEL0	FLGERR	SW1SEL2	SW1SEL1	SW1SEL0
Initial value	0	0	0	0	0	0	0	0
Setting	R/W	R/W	R/W	R/W	R/W	R/W	R/W	R/W

SW1SEL[2:0] MCKOUT, BCKOUT, LRCKOUT, and DATAOUT output setting

- 000: ADC/DIR automatically selected output setting (initial value)
  - When PLL is unlocked: When ADC master mode clocks are set
    - MCKOUT: ADC master clock output
    - BCKOUT: ADC bit clock output
    - LRCKOUT: ADC channel clock output
    - DATAOUT: ADC audio data output
  - When PLL is unlocked: When ADC slave mode clocks are set
    - MCKOUT: MPIO1 pin input master clock output
    - BCKOUT: MPIO2 pin input bit clock output
    - LRCKOUT: MPIO3 pin input channel clock output
    - DATAOUT: ADC audio data output
  - When PLL is locked: DIR output
    - MCKOUT: DIR master clock output
    - BCKOUT: DIR bit clock output
    - LRCKOUT: DIR channel clock output
    - DATAOUT: DIR audio data output
- 001: ADC output (master mode/slave mode)
  - MCKOUT: ADC master/MPIO1 pin input clock output
  - BCKOUT: ADC bit/MPIO2 pin input clock output
  - LRCKOUT: ADC channel/MPIO3 pin input clock output
  - DATAOUT: ADC audio data output
- 010: MCKIN, BCKIN, LRCKIN, and DATAIN pin input signal output (2ch/8ch data supported)
  - MCKOUT: MCKIN pin input master clock output
  - BCKOUT: BCKIN pin input bit clock output
  - LRCKOUT: LRCKIN pin input channel clock output
  - DATAOUT: DATAIN pin input 2ch/8ch supported audio data output
- 011: MPIN[4:1] pin input signal output (2ch/6ch data supported)
  - MCKOUT: MPIN1 pin input master clock output
  - BCKOUT: MPIN2 pin input bit clock output
  - LRCKOUT: MPIN3 pin input channel clock output
  - DATAOUT: MPIN4 pin input 2ch/6ch supported audio data output
- 100: MPIO[4:1] pin input signal output (“MPSEL[1:0]=01” setting)
  - MCKOUT: MPIO1 pin input master clock output
  - BCKOUT: MPIO2 pin input bit clock output
  - LRCKOUT: MPIO3 pin input channel clock output
  - DATAOUT: MPIO4 pin input 2ch supported audio data output
- 101: RXIN[8:5] pin input signal output
  - MCKOUT: RXIN8 pin input master clock output
  - BCKOUT: RXIN7 pin input bit clock output
  - LRCKOUT: RXIN6 pin input channel clock output
  - DATAOUT: RXIN5 pin input 2ch supported audio data output

Continued on next page.

Continued from preceding page.

- SW1SEL[2:0] 110: “L” output (OUTMUT register must be used ‘Sound’ detection when operates with low current consumption setting)  
MCKOUT: “L” output (“H” output when “MCKOUTP=1” is set)  
BCKOUT: “L” output  
LRCKOUT: “L” output  
DATAOUT: “L” output
- 111: “L” output (OUTMUT register must be used ‘Sound’ detection when operates with low current consumption setting)  
MCKOUT: “L” output (“H” output when “MCKOUTP=1” is set)  
BCKOUT: “L” output  
LRCKOUT: “L” output  
DATAOUT: “L” output

- FLGERR ERRF output setting
- 0: Output according to the RXRESEL, RXREDER, and RXRESTA register settings (initial value).
  - 1: The MPIN4 pin input signal is output (polarity can be inverted using the MPIN4P register)

- SW2SEL[2:0] MPOUT[4:1] output setting
- 000: “L” output (initial value)
    - MPOUT1: “L” output
    - MPOUT2: “L” output
    - MPOUT3: “L” output
    - MPOUT4: S/PDIF output (initial value is “L”, subject to RXTHR2[3:0] register)
  - 001: ADC output (master mode/slave mode)
    - MPOUT1: ADC master/MPIO1 pin input clock output
    - MPOUT2: ADC bit/MPIO2 pin input clock output
    - MPOUT3: ADC channel/MPIO3 pin input clock output
    - MPOUT4: ADC audio data output
  - 010: MCKIN, BCKIN, LRCKIN, and DATAIN pin input signal output (2ch data supported)
    - MPOUT1: MCKIN pin input master clock output
    - MPOUT2: BCKIN pin input bit clock output
    - MPOUT3: LRCKIN pin input channel clock output
    - MPOUT4: DATAIN pin input 2ch supported audio data output
  - 011: MPIN[4:1] pin input signal output (2ch data supported)
    - MPOUT1: MPIN1 pin input master clock output
    - MPOUT2: MPIN2 pin input bit clock output
    - MPOUT3: MPIN3 pin input channel clock output
    - MPOUT4: MPIN4 pin input 2ch supported audio data output
  - 100: MPIO[4:1] pin input signal output (“MPSEL[1:0]=01” setting)
    - MPOUT1: MPIO1 pin input master clock output
    - MPOUT2: MPIO2 pin input bit clock output
    - MPOUT3: MPIO3 pin input channel clock output
    - MPOUT4: MPIO4 pin input 2ch supported audio data output
  - 101: RXIN[8:5] pin input signal output
    - MPOUT1: RXIN8 pin input master clock output
    - MPOUT2: RXIN7 pin input bit clock output
    - MPOUT3: RXIN6 pin input channel clock output
    - MPOUT4: RXIN5 pin input 2ch supported audio data output

Continued on next page.

Continued from preceding page.

- SW2SEL[2:0]      110: MPIN[6:5] pin input signal output (6ch data supported)  
                                MPOUT1: MPIN5 pin input 6ch supported audio data output  
                                MPOUT2: MPIN6 pin input 6ch supported audio data output  
                                MPOUT3: “L” output  
                                MPOUT4: S/PDIF output (initial value is “L”, subject to RXTHR2[3:0] register)
- 111: MPIN[3:1] pin input signal output (8ch data supported)  
  MPOUT1: MPIN1 pin input 8ch supported audio data output  
  MPOUT2: MPIN2 pin input 8ch supported audio data output  
  MPOUT3: MPIN3 pin input 8ch supported audio data output  
  MPOUT4: S/PDIF output (initial value is “L”, subject to RXTHR2[3:0] register)
- FLGOUT      MUTE<sub>B</sub> and NPCMF output setting
- 0: MUTE<sub>B</sub>: Mute signal generated by the DIR (initial value).  
  NPCMF: Non-PCM information generated by the DIR (initial value).
- 1: MUTE<sub>B</sub>: MPIN5 pin input signal is output (polarity is inverted by MPIN5P register).  
  NPCMF: MPIN6 pin input signal is output (polarity is inverted by MPIN6P register).

- The SW1SEL[2:0], FLGERR, SW2SEL[2:0] and FLGOUT register settings are processed according to the MUXMOD register. When “MUXMOD=1”, the SW1SEL[2:0], FLGERR, SW2SEL[2:0] and FLGOUT register settings must be made in the LR clock constantly supplied status. When LR clock supply is stopped, these register settings are not executed.
- The change of MPIO[4:1] pins to the input terminal is set to “MPSEL[1:0]=01”.
- When “SW1SEL[2:0]=001” is set, the DIR is unlocked regardless of whether there is digital data, and the error flag is output from ERRF. When switched from the PLL locked status, the ADC data is output after mute processing (MUTE<sub>B</sub> pulse output period).
- The setting and the release of “SW2SEL[2:0]=001” are executed via the reset processing of ADC. When the ADC data is output from DATAOUT by “SW1SEL[2:0]=000” or “SW1SEL[2:0]=001”, MUTE<sub>B</sub> is changed by “SW2SEL[2:0]=001”. And, DATAOUT is muted while ADC is being reset. “SW2SEL[2:0]=001” is recommended to be set or release after DATAOUT output data is muted. When the demodulation data of DIR is output from DATAOUT by “SW1SEL[2:0]=000”, setting or release of “SW2SEL[2:0]=001” dose not influence DATAOUT because the reset processing of ADC is not reflected in MUTE<sub>B</sub> at this time. When the slave of ADC is set, these are similar.
- 6-channel data and 8-channel data processing are set as follows.
  - 6-channel data processing: “SW1SEL[2:0]=011” and “SW2SEL[2:0]=110”
  - 8-channel data processing: “SW1SEL[2:0]=010” and “SW2SEL[2:0]=111”
- In order to switch the ERRF, MUTE<sub>B</sub> and NPCMF outputs to the MPIN4, MPIN5 and MPIN6 input signals when switching to 8-channel data, also change the FLGERR and FLGOUT register settings at the same time as the SW1SEL[2:0] and SW2SEL[2:0] settings.
- When “DSTATE=1”, the ‘Sound’ or ‘Silence’ detection is executed for the output data selected with SW1SEL[2:0] register. When the output buffer function of the clock and data are stopped and current consumption is decreased, the OUTMUT register is set. Note that ‘Sound’ detection dose not function when the output function of the clock and data are stopped with “SW1SEL[2:0]=110 or 111” (“L” output).

## LC89075WA

Address: 07h; ADC 'Sound' or 'Silence' Detection Level Setting

07h	D7	D6	D5	D4	D3	D2	D1	D0
Register name	NLEVEL3	NLEVEL2	NLEVEL1	NLEVEL0	YLEVEL3	YLEVEL2	YLEVEL1	YLEVEL0
Initial value	0	0	0	0	0	0	0	0
Setting	R/W	R/W	R/W	R/W	R/W	R/W	R/W	R/W

YLEVEL[3:0] PCM data 'Sound' detection setting ('Sound' is judged when the signal is larger than the set value).

0000: -60dBFS (initial value)  
0001: -58dBFS  
0010: -56dBFS  
0011: -54dBFS  
0100: -52dBFS  
0101: -50dBFS  
0110: -48dBFS  
0111: -46dBFS  
1000: -44dBFS  
1001: -42dBFS  
1010: -40dBFS  
1011: -38dBFS  
1100: -36dBFS  
1101: -34dBFS  
1110: -32dBFS  
1111: -30dBFS

NLEVEL[3:0] PCM data 'Silence' detection setting ('Silence' is judged when the signal is smaller than the set value).

0000: -60dBFS (initial value)  
0001: -58dBFS  
0010: -56dBFS  
0011: -54dBFS  
0100: -52dBFS  
0101: -50dBFS  
0110: -48dBFS  
0111: -46dBFS  
1000: -44dBFS  
1001: -42dBFS  
1010: -40dBFS  
1011: -38dBFS  
1100: -36dBFS  
1101: -34dBFS  
1110: -32dBFS  
1111: -30dBFS

- 0dBFS = 0.6AV<sub>DD</sub>
- The judgment levels can be adjusted from -30dBFS to -60dBFS in 2dBFS steps with the YLEVEL[3:0] and NLEVEL[3:0] registers.
- When performing detection on analog data, the judgment level variations can be increased by also using the ADPGA[2:0] register that sets the PGA. However, care should be taken for the ADPGA[2:0] register setting, as it affects the normal ADC operation.

# LC89075WA

Address: 08h; ADC Data Control Setting

08h	D7	D6	D5	D4	D3	D2	D1	D0
Register name	ADBMOD	ADPGA2	ADPGA1	ADPGA0	ADSMUTE	ADFDSP2	ADFDSP1	ADFDSP0
Initial value	0	0	0	0	0	0	0	0
Setting	R/W	R/W	R/W	R/W	R/W	R	R/W	R/W

**ADFDSP[2:0]**    ADC soft mute and attenuator transition time setting

- 000: 1/fs (initial value) (Reference: Transition time from 0dB => -∞ is 256/fs)
- 001: 2/fs (Reference: Transition time from 0dB => -∞ is 512/fs)
- 010: 4/fs (Reference: Transition time from 0dB => -∞ is 1024/fs)
- 011: 8/fs (Reference: Transition time from 0dB => -∞ is 2048/fs)
- 100: 16/fs (Reference: Transition time from 0dB => -∞ is 4096/fs)
- 101: Reserved
- 110: Reserved
- 111: Direct (Reference: Transition time from 0dB => -∞ is 1/fs)

**ADSMUTE**    ADC output mute function setting

- 0: Cancel the soft mute mode (initial value).
- 1: Start the soft mute.

**ADPGA[2:0]**    ADC input PGA setting

- 000: 0 (initial value)
- 001: -1.5dB
- 010: -3dB
- 011: -4.5dB
- 100: +1.5dB
- 101: +3dB
- 110: +4.5dB
- 111: +6dB

**ADBMOD**    Audio data output waiting time setting when ADC reset is released

- 0: The audio data is output after 16384/fs (initial value).
- 1: The audio data is output immediately after release of reset.

- The ADC soft mute and attenuator gain changes in 0.25dB steps.
- The transition time is calculated from the following formula. Other than when “ADFDSP[2:0]=000” or “ADVOL[7:0]=FFh” is set.

$$\begin{aligned}
 & \text{Transition time from the ADVOL[7:0] register setting value to } -\infty \\
 & = (256 - \text{ADVOL}[7:0]) \times \text{ADFDSP}[2:0] \\
 & = (256 - (0, 0.25, 0.5, 0.75 \dots 63.5\text{dB}/0.25\text{dB})) \times (1/\text{fs}, 2/\text{fs}, 4/\text{fs}, 8/\text{fs}, 16/\text{fs})
 \end{aligned}$$



## LC89075WA

Address: 09h; ADC Output Attenuator Setting

09h	D7	D6	D5	D4	D3	D2	D1	D0
Register name	ADVOL7	ADVOL6	ADVOL5	ADVOL4	ADVOL3	ADVOL2	ADVOL1	ADVOL0
Initial value	0	0	0	0	0	0	0	0
Setting	R/W	R/W	R/W	R/W	R/W	R/W	R/W	R/W

ADVOL[7:0] ADC output volume setting (initial value: 0000\_0000: 0dB)

0000_0000:	0dB,	0010_1000:	-10.00dB,	0101_0000:	-20.00dB
0000_0001:	-0.25dB,	0010_1001:	-10.25dB,	0101_0001:	-20.25dB
0000_0010:	-0.50dB,	0010_1010:	-10.50dB,	0101_0010:	-20.50dB
0000_0011:	-0.75dB,	0010_1011:	-10.75dB,	0101_0011:	-20.75dB
0000_0100:	-1.00dB,	0010_1100:	-11.00dB,	0101_0100:	-21.00dB
0000_0101:	-1.25dB,	0010_1101:	-11.25dB,	0101_0101:	-21.25dB
0000_0110:	-1.50dB,	0010_1110:	-11.50dB,	0101_0110:	-21.50dB
0000_0111:	-1.75dB,	0010_1111:	-11.75dB,	0101_0111:	-21.75dB
0000_1000:	-2.00dB,	0011_0000:	-12.00dB,	0101_1000:	-22.00dB
0000_1001:	-2.25dB,	0011_0001:	-12.25dB,	0101_1001:	-22.25dB
0000_1010:	-2.50dB,	0011_0010:	-12.50dB,	0101_1010:	-22.50dB
0000_1011:	-2.75dB,	0011_0011:	-12.75dB,	0101_1011:	-22.75dB
0000_1100:	-3.00dB,	0011_0100:	-13.00dB,	0101_1100:	-23.00dB
0000_1101:	-3.25dB,	0011_0101:	-13.25dB,	0101_1101:	-23.25dB
0000_1110:	-3.50dB,	0011_0110:	-13.50dB,	0101_1110:	-23.50dB
0000_1111:	-3.75dB,	0011_0111:	-13.75dB,	0101_1111:	-23.75dB
0001_0000:	-4.00dB,	0011_1000:	-14.00dB,	0110_0000:	-24.00dB
0001_0001:	-4.25dB,	0011_1001:	-14.25dB,	0110_0001:	-24.25dB
0001_0010:	-4.50dB,	0011_1010:	-14.50dB,	0110_0010:	-24.50dB
0001_0011:	-4.75dB,	0011_1011:	-14.75dB,	0110_0011:	-24.75dB
0001_0100:	-5.00dB,	0011_1100:	-15.00dB,	0110_0100:	-25.00dB
0001_0101:	-5.25dB,	0011_1101:	-15.25dB,	0110_0101:	-25.25dB
0001_0110:	-5.50dB,	0011_1110:	-15.50dB,	0110_0110:	-25.50dB
0001_0111:	-5.75dB,	0011_1111:	-15.75dB,	0110_0111:	-25.75dB
0001_1000:	-6.00dB,	0100_0000:	-16.00dB,	0110_1000:	-26.00dB
0001_1001:	-6.25dB,	0100_0001:	-16.25dB,	0110_1001:	-26.25dB
0001_1010:	-6.50dB,	0100_0010:	-16.50dB,	0110_1010:	-26.50dB
0001_1011:	-6.75dB,	0100_0011:	-16.75dB,	0110_1011:	-26.75dB
0001_1100:	-7.00dB,	0100_0100:	-17.00dB,	0110_1100:	-27.00dB
0001_1101:	-7.25dB,	0100_0101:	-17.25dB,	0110_1101:	-27.25dB
0001_1110:	-7.50dB,	0100_0110:	-17.50dB,	0110_1110:	-27.50dB
0001_1111:	-7.75dB,	0100_0111:	-17.75dB,	0110_1111:	-27.75dB
0010_0000:	-8.00dB,	0100_1000:	-18.00dB,	0111_0000:	-28.00dB
0010_0001:	-8.25dB,	0100_1001:	-18.25dB,	0111_0001:	-28.25dB
0010_0010:	-8.50dB,	0100_1010:	-18.50dB,	0111_0010:	-28.50dB
0010_0011:	-8.75dB,	0100_1011:	-18.75dB,	0111_0011:	-28.75dB
0010_0100:	-9.00dB,	0100_1100:	-19.00dB,	0111_0100:	-29.00dB
0010_0101:	-9.25dB,	0100_1101:	-19.25dB,	0111_0101:	-29.25dB
0010_0110:	-9.50dB,	0100_1110:	-19.50dB,	0111_0110:	-29.50dB
0010_0111:	-9.75dB,	0100_1111:	-19.75dB,	0111_0111:	-29.75dB

Continued on next page.

## LC89075WA

Continued from preceding page.

ADVOL[7:0]	0111_1000: -30.00dB,	1010_1000: -42.00dB,	1101_1000: -54.00dB
	0111_1001: -30.25dB,	1010_1001: -42.25dB,	1101_1001: -54.25dB
	0111_1010: -30.50dB,	1010_1010: -42.50dB,	1101_1010: -54.50dB
	0111_1011: -30.75dB,	1010_1011: -42.75dB,	1101_1011: -54.75dB
	0111_1100: -31.00dB,	1010_1100: -43.00dB,	1101_1100: -55.00dB
	0111_1101: -31.25dB,	1010_1101: -43.25dB,	1101_1101: -55.25dB
	0111_1110: -31.50dB,	1010_1110: -43.50dB,	1101_1110: -55.50dB
	0111_1111: -31.75dB,	1010_1111: -43.75dB,	1101_1111: -55.75dB
	1000_0000: -32.00dB,	1011_0000: -44.00dB,	1110_0000: -56.00dB
	1000_0001: -32.25dB,	1011_0001: -44.25dB,	1110_0001: -56.25dB
	1000_0010: -32.50dB,	1011_0010: -44.50dB,	1110_0010: -56.50dB
	1000_0011: -32.75dB,	1011_0011: -44.75dB,	1110_0011: -56.75dB
	1000_0100: -33.00dB,	1011_0100: -45.00dB,	1110_0100: -57.00dB
	1000_0101: -33.25dB,	1011_0101: -45.25dB,	1110_0101: -57.25dB
	1000_0110: -33.50dB,	1011_0110: -45.50dB,	1110_0110: -57.50dB
	1000_0111: -33.75dB,	1011_0111: -45.75dB,	1110_0111: -57.75dB
	1000_1000: -34.00dB,	1011_1000: -46.00dB,	1110_1000: -58.00dB
	1000_1001: -34.25dB,	1011_1001: -46.25dB,	1110_1001: -58.25dB
	1000_1010: -34.50dB,	1011_1010: -46.50dB,	1110_1010: -58.50dB
	1000_1011: -34.75dB,	1011_1011: -46.75dB,	1110_1011: -58.75dB
	1000_1100: -35.00dB,	1011_1100: -47.00dB,	1110_1100: -59.00dB
	1000_1101: -35.25dB,	1011_1101: -47.25dB,	1110_1101: -59.25dB
	1000_1110: -35.50dB,	1011_1110: -47.50dB,	1110_1110: -59.50dB
	1000_1111: -35.75dB,	1011_1111: -47.75dB,	1110_1111: -59.75dB
	1001_0000: -36.00dB,	1100_0000: -48.00dB,	1111_0000: -60.00dB
	1001_0001: -36.25dB,	1100_0001: -48.25dB,	1111_0001: -60.25dB
	1001_0010: -36.50dB,	1100_0010: -48.50dB,	1111_0010: -60.50dB
	1001_0011: -36.75dB,	1100_0011: -48.75dB,	1111_0011: -60.75dB
	1001_0100: -37.00dB,	1100_0100: -49.00dB,	1111_0100: -61.00dB
	1001_0101: -37.25dB,	1100_0101: -49.25dB,	1111_0101: -61.25dB
	1001_0110: -37.50dB,	1100_0110: -49.50dB,	1111_0110: -61.50dB
	1001_0111: -37.75dB,	1100_0111: -49.75dB,	1111_0111: -61.75dB
	1001_1000: -38.00dB,	1100_1000: -50.00dB,	1111_1000: -62.00dB
	1001_1001: -38.25dB,	1100_1001: -50.25dB,	1111_1001: -62.25dB
	1001_1010: -38.50dB,	1100_1010: -50.50dB,	1111_1010: -62.50dB
	1001_1011: -38.75dB,	1100_1011: -50.75dB,	1111_1011: -62.75dB
	1001_1100: -39.00dB,	1100_1100: -51.00dB,	1111_1100: -63.00dB
	1001_1101: -39.25dB,	1100_1101: -51.25dB,	1111_1101: -63.25dB
	1001_1110: -39.50dB,	1100_1110: -51.50dB,	1111_1110: -63.50dB
	1001_1111: -39.75dB,	1100_1111: -51.75dB,	1111_1111: -∞dB
	1010_0000: -40.00dB,	1101_0000: -52.00dB,	
	1010_0001: -40.25dB,	1101_0001: -52.25dB,	
	1010_0010: -40.50dB,	1101_0010: -52.50dB,	
	1010_0011: -40.75dB,	1101_0011: -52.75dB,	
	1010_0100: -41.00dB,	1101_0100: -53.00dB,	
	1010_0101: -41.25dB,	1101_0101: -53.25dB,	
	1010_0110: -41.50dB,	1101_0110: -53.50dB,	
	1010_0111: -41.75dB,	1101_0111: -53.75dB,	

# LC89075WA

Address: 0Ah; DIR Clock Setting

0Ah	D7	D6	D5	D4	D3	D2	D1	D0
Register name	RXCKWT1	RXCKWT0	RXMCK1	RXMCK0	RXCKDV1	RXCKDV0	0	RXCKAT
Initial value	0	0	0	0	0	0	0	0
Setting	R/W	R/W	R/W	R/W	R/W	R/W	R	R/W

RXCKAT      PLL clock lock frequency setting  
                     0: Automatic control (initial value)  
                     1: Manual setting

RXCKDV[1:0]    PLL lock time MCKOUT output setting when RXCKAT is set to 0

- 00: 512fs output: When receiving 32kHz, 44.1kHz, 48kHz (initial value)  
       256fs output: When receiving 64kHz, 88.2kHz, 96kHz  
       128fs output: When receiving 128kHz, 176.4kHz, 192kHz
- 01: 256fs output: When receiving 32kHz, 44.1kHz, 48kHz  
       256fs output: When receiving 64kHz, 88.2kHz, 96kHz  
       128fs output: When receiving 128kHz, 176.4kHz, 192kHz
- 10: 512fs output: When receiving 32kHz, 44.1kHz, 48kHz  
       512fs output: When receiving 64kHz, 88.2kHz, 96kHz  
       128fs output: When receiving 128kHz, 176.4kHz, 192kHz
- 11: 256fs output: When receiving 32kHz, 44.1kHz, 48kHz  
       512fs output: When receiving 64kHz, 88.2kHz, 96kHz  
       128fs output: When receiving 128kHz, 176.4kHz, 192kHz

RXMCK[1:0]    PLL lock time MCKOUT output setting when RXCKAT is set to 1

- 00: 256fs output (initial value)
- 01: 512fs output
- 10: 128fs output
- 11: Reserved

RXCKWT[1:0]    Clock switching wait time setting

- 00: The clocks is switched 2.7ms after PLL locked status is judged (initial value).
- 01: The clock is switched 1.3ms after PLL locked status is judged.
- 10: The clock is switched 0.7ms after PLL locked status is judged.
- 11: Reserved

- When input fs calculation cannot be done by “RXCKAT=0”, the PLL clock is set to 256fs output.
- Set the RXCKAT,RXCKDEV[1:0] and RXMCK[1:0] register while the PLL is unlocked. This setting is executed after the PLL is locked. However, after PLL is locked, RXMCK[1:0] register can change by RXCKMU register.

# LC89075WA

Address: 0Bh; DIR Demodulation Data, Through Data Setting

0Bh	D7	D6	D5	D4	D3	D2	D1	D0
Register name	RXDSEL3	RXDSEL2	RXDSEL1	RXDSEL0	RXTHR13	RXTHR12	RXTHR11	RXTHR10
Initial value	0	0	0	0	1	1	1	1
Setting	R/W	R/W	R/W	R/W	R/W	R/W	R/W	R/W

RXTHR1[3:0] RXOUT output data setting

0000: RXIN1  
0001: RXIN2  
0010: RXIN3  
0011: RXIN4  
0100: RXIN5  
0101: RXIN6  
0110: RXIN7  
0111: RXIN8  
1000: RXIN1A  
1001: RXIN2A  
1010: RXIN3A  
1011: MPIO1  
1100: MPIO2  
1101: MPIO3  
1110: MPIO4  
1111: Fixed at "L" (initial value).

RXDSEL[3:0] Data demodulation input setting

0000: RXIN1 (initial value)  
0001: RXIN2  
0010: RXIN3  
0011: RXIN4  
0100: RXIN5  
0101: RXIN6  
0110: RXIN7  
0111: RXIN8  
1000: RXIN1A  
1001: RXIN2A  
1010: RXIN3A  
1011: MPIO1  
1100: MPIO2  
1101: MPIO3  
1110: MPIO4  
1111: Connected to GND.

- The MPIO[4:1] data input is used by "MPSEL[1:0]=01".

## LC89075WA

Address: 0Ch; DIR Through Data Setting

0Ch	D7	D6	D5	D4	D3	D2	D1	D0
Register name	0	0	0	0	RXTHR23	RXTHR22	RXTHR21	RXTHR20
Initial value	0	0	0	0	1	1	1	1
Setting	R	R	R	R	R/W	R/W	R/W	R/W

RXTHR2[3:0] MPOUT4 output data setting (conforms to SW2SEL[2:0] setting).

0000: RXIN1  
0001: RXIN2  
0010: RXIN3  
0011: RXIN4  
0100: RXIN5  
0101: RXIN6  
0110: RXIN7  
0111: RXIN8  
1000: RXIN1A  
1001: RXIN2A  
1010: RXIN3A  
1011: MPIO1  
1100: MPIO2  
1101: MPIO3  
1110: MPIO4  
1111: Fixed at "L" (initial value).

- The RXTHR2[3:0] register setting contents are output from MPOUT4, but the MPOUT4 setting conforms to the SW2SEL[2:0] register.

## LC89075WA

Address: 0Dh; DIR System Setting

0Dh	D7	D6	D5	D4	D3	D2	D1	D0
Register name	RXERWT1	RXERWT0	RXLIM1	RXLIM0	RXREFSJ	RXRESTA	RXREDER	RXRESEL
Initial value	0	0	0	0	0	0	0	0
Setting	R/W	R/W	R/W	R/W	R/W	R/W	R/W	R/W

**RXRESEL**      ERRF output contents setting

- 0: PLL lock error or data error (initial value)
- 1: PLL lock error or data error or non-PCM data

**RXREDER**      Flag output setting for 8 or fewer consecutive parity errors

- 0: Output only when non-PCM data is recognized (initial value).
- 1: Output only during the sub-frame in which error occurred.

**RXRESTA**      ERRF output condition setting

- 0: Always output PLL status (initial value).
- 1: Forced to error output "H"

**RXREFSJ**      Set the ERRF output conditions due to input fs change.

- 0: Input fs change after error is canceled is not reflected to ERRF (initial value).
- 1: Input fs change after the error is canceled is reflected to ERRF.

**RXLIM[1:0]**    DIR receive range setting

- 00: No limitation (initial value)
- 01:  $f_s \leq 96\text{kHz}$  (When exceeded, data is muted and XIN system clock is output.)
- 10:  $f_s \leq 48\text{kHz}$  (When exceeded, data is muted and XIN system clock is output.)
- 11: Reserved

**RXERWT[1:0]**   ERRF wait time setting after PLL is locked.

- 00: The error is canceled after 3 occurrences of preamble B are counted (initial value).
- 01: Error is canceled after 6 occurrences of preamble B are counted.
- 10: Error is canceled after 12 occurrences of preamble B are counted.
- 11: Error is canceled after 24 occurrences of preamble B are counted.

- The non-PCM data is the same as the detection data output on NPCMF.
- When an error is indicated in the RXRESEL register due to non-PCM data, the output data is muted.
- The RXRESTA register has no effect on the data and clock output pins.
- When "RXREFSJ=0", sources with changing fs (CD players with variable pitch functions, etc.) are supported. If it is a change in the capture-range of PLL, PLL does not become a lock error.
- "RXREFSJ=1" is set that when the change in input fs exceeds the range of the calculation after releasing the error, the error is output.
- The RXERWT[1:0] register setting defines the time after the PLL is locked until ERRF outputs "L" to cancel the error. The demodulated audio data is output after the ERRF error is canceled, so when problems occur such as the start of the data being cut off, change this setting.

## LC89075WA

Address: 0Eh; DIR Interrupt Source Setting

0Eh	D7	D6	D5	D4	D3	D2	D1	D0
Register name	DATAM	0	EMPHA	PCRNW	UNPCM	CSRNW	FSCHG	ERROR
Initial value	0	0	0	0	0	0	0	0
Setting	R/W	R	R/W	R/W	R/W	R/W	R/W	R/W

ERROR      ERRF output status change output setting

- 0: Not output (initial value)
- 1: Output ERRF status change.

FSCHG      Setting the output of the input fs calculation result update flag

- 0: Not output (initial value).
- 1: Output the update flag of the input fs calculation result.

CSRNW      Setting the output of the first 40 bits channel status data update flag

- 0: Not output (initial value)
- 1: Output the update flag of the first 40 bits channel status data.

UNPCM      NPCMF output status change output setting

- 0: Not output (initial value).
- 1: Output the change in NPCMF status.

PCRNW      Burst preamble Pc update flag output setting

- 0: Not output (initial value)
- 1: Output the update flag of the burst preamble Pc.

EMPHA      Emphasis detection flag output setting

- 0: Not output (initial value).
- 1: Output the emphasis detection flag.

DATAM      DSTATE output status change output setting

- 0: Not output (initial value)
- 1: Output the change in DSTATE status.

- The channel status update flag process compares the first 40 bits of data of the previous block with the current data. When the data match, the data is considered to have been updated and the update flag is output.
- Likewise, the burst preamble Pc update flag process compares the 16 bits of data of the previous block with the current data. When the data match, the update flag is output.

## LC89075WA

Address: 0Fh; DIR Interrupt Source Readout

0Fh	D7	D6	D5	D4	D3	D2	D1	D0
Register name	ODATAM	0	OEMPHA	OPCRNW	OUNPCM	OCSRNW	OFSCHG	OERROR
Setting	R	R	R	R	R	R	R	R

- OERROR      ERRF output status (output the status when read)  
0: No transfer error with the PLL locked  
1: PLL unlocked state or transfer error exists.
- OFSCHG      Input fs calculation update result (cleared after readout)  
0: No input fs calculation update  
1: Input fs calculation is updated.
- OCSRNW      First 40 bits channel status update result (cleared after readout)  
0: No update  
1: Updated
- OUNPCM      NPCMF output status (output the status when read)  
0: No non-PCM signal detection  
1: Non-PCM signal detected
- OPCRNW      Burst preamble Pc update result (cleared after readout)  
0: No update  
1: Updated
- OEMPF      Detection of channel status emphasis (output the status when read)  
0: No pre-emphasis  
1: 50/15 $\mu$ s pre-emphasis exists.
- ODATAM      DSTATE output status (output the status when read)  
0: 'Silence' state or ADC reset state  
1: 'Sound' state

- The ERRF, NPCMF and DSTATE pin statuses can be read from the OERROR, OUNPCM and ODATAM registers, regardless of the INTB output setting.
- The channel status information can be read from the OEMPF register, regardless of the INTB output setting.



## LC89075WA

Address: 10h; DIR Receive Sampling Frequency, Data Type Readout

10h	D7	D6	D5	D4	D3	D2	D1	D0
Register name	RSDTSES	RXDTS51	RX61937	RXFSFLG	RXFSC3	RXFSC2	RXFSC1	RXFSC0
Setting	R	R	R	R	R	R	R	R

RXFSC[3:0] Input data fs calculation result

0000: 44.1kHz

0001: Out of range

0010: 48kHz

0011: 32kHz

0100: -

0101: -

0110: -

0111: -

1000: 88.2kHz

1001: -

1010: 96kHz

1011: 64kHz

1100: 176.4kHz

1101: 128kHz

1110: 192kHz

1111: -

RXFSFLG Comparison between input data sampling frequency calculation results and channel status fs information

0: No match in input sampling frequency information

1: Match in input sampling frequency information

RX61937 IEC61937 burst preamble detection

0: Neither Pa nor Pb is detected.

1: Pa and Pb are detected.

RXDTS51 DTS-CD 5.1ch sync signal detection

0: No DTS-CD sync signal detected

1: DTS-CD sync signal detected

RXDTSSES DTS-CD(ES) 6.1ch sync signal detection

0: No DTS-CD(ES) sync signal detected

1: DTS ES-CD(ES) sync signal detected

- The RXFSFLG register compares the calculated sampling frequency value of the input data with the fs information of the channel status, and is output when the sampling frequency results match.
- When the DTS-CD(ES) sync signal of the RXDTSSES register is detected, the DTS-CD sync signal of the RXDTS51 register is also detected at the same time.

# LC89075WA

Address: 11h-15h; DIR Channel Status Readout (Read-only)

Address	D7	D6	D5	D4	D3	D2	D1	D0
11h	RXCS7	RXCS6	RXCS5	RXCS4	RXCS3	RXCS2	RXCS1	RXCS0
12h	RXCS15	RXCS14	RXCS13	RXCS12	RXCS11	RXCS10	RXCS9	RXCS8
13h	RXCS23	RXCS22	RXCS21	RXCS20	RXCS19	RXCS18	RXCS17	RXCS16
14h	RXCS31	RXCS30	RXCS29	RXCS28	RXCS27	RXCS26	RXCS25	RXCS24
15h	RXCS39	RXCS38	RXCS37	RXCS36	RXCS35	RXCS34	RXCS33	RXCS32

Table 14.3 Read Register Contents of First 40 Bits of Channel Status

Adr	Reg	CS Bit	Description	Adr	Reg	CS Bit	Description
11h	RXCS0	bit0	Application	13h	RXCS20	bit20	Channel number
	RXCS1	bit1	Control		RXCS21	bit21	
	RXCS2	bit2			RXCS22	bit22	
	RXCS3	bit3			RXCS23	bit23	
	RXCS4	bit4		14h	RXCS24	bit24	Sampling frequency
	RXCS5	bit5	RXCS25		bit25		
	RXCS6	bit6	RXCS26		bit26		
	RXCS7	bit7	RXCS27		bit27		
12h	RXCS8	bit8	Category code	RXCS28	bit32	Clock accuracy	
	RXCS9	bit9		RXCS29	bit33		
	RXCS10	bit10		RXCS30	bit30	Not defined	
	RXCS11	bit11		RXCS31	bit31		
	RXCS12	bit12		15h	RXCS32		bit32
	RXCS13	bit13			RXCS33	bit33	
	RXCS14	bit14			RXCS34	bit34	
	RXCS15	bit15			RXCS35	bit35	
13h	RXCS16	bit16	Source number	RXCS36	bit36	Original sampling frequency	
	RXCS17	bit17		RXCS37	bit37		
	RXCS18	bit18		RXCS38	bit38		
	RXCS19	bit19		RXCS39	bit39		

- For details, check the IEC60958 Specifications.

# LC89075WA

Address: 16h-17h; DIR Burst Preamble Pc Readout (Read-only)

address	D7	D6	D5	D4	D3	D2	D1	D0
16h	RXPC7	RXPC6	RXPC5	RXPC4	RXPC3	RXPC2	RXPC1	RXPC0
17h	RXPC15	RXPC14	RXPC13	RXPC12	RXPC11	RXPC10	RXPC9	RXPC8

Table 14.4 Burst Preamble Pc Read Registers

Adr.	Register	Pc Bit	Description
16h	RXPC0	bit0	Data type
	RXPC1	bit1	
	RXPC2	bit2	
	RXPC3	bit3	
	RXPC4	bit4	Reserved
	RXPC5	bit5	
	RXPC6	bit6	
	RXPC7	bit7	Error
17h	RXPC8	bit8	Data type dependent information
	RXPC9	bit9	
	RXPC10	bit10	
	RXPC11	bit11	
	RXPC12	bit12	
	RXPC13	bit13	Bit stream number
	RXPC14	bit14	
	RXPC15	bit15	

Table 14.5 Burst Preamble Pc Data Type Field

Register	Value	Description
RXPC[4:0]	0	NULL data
	1	Dolby AC3 data
	2	Reserved
	3	Pause
	4	MPEG-1, layer 1 data
	5	MPEG-1, layer 2 or 3 data or non-extended MPEG-2
	6	Extended MPEG-2 data
	7	Reserved
	8	MPEG-2, layer 1, low sampling rate
	9	MPEG-2, layer 2, 3, low sampling rate
	10	Reserved
	11	DTS type 1
	12	DTS type 2
	13	DTS type 3
	14	ATRAC
	15	ATRAC 2/3
	16-26	Reserved
	27	Reserved (MPEG-4, AAC data)
	28	MPEG-2, AAC data
	29-31	Reserved

- For the latest information, check the specifications issued from each license.

15. Application Example

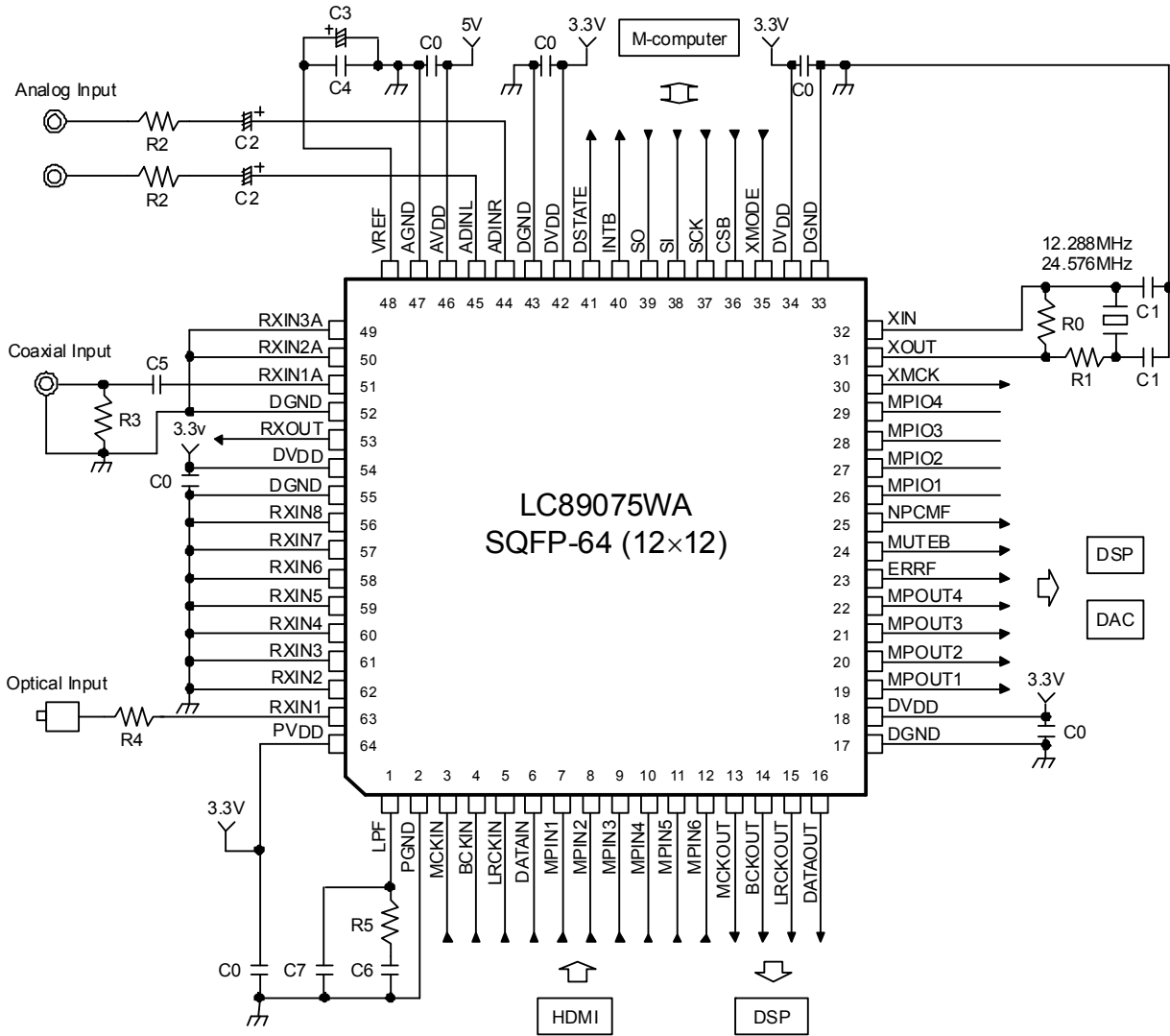

Element Symbol	Recommended Parameter	Application	Remarks
C0	0.1μF	Power supply de-coupling	Ceramic capacitor
R0	1MΩ	Oscillation amplifier feedback	
R1	150Ω to 2.2kΩ	Oscillation amplifier current limit	
C1	1pF to 33pF	Quartz resonator load	Ceramic capacitor with NP0 characteristics
R2	10kΩ to 100kΩ	ADC analog input	See 9.4
C2	0.1μF to 10μF	ADC analog input	See 9.4
C3	10μF	ADC common voltage smoothing	See 8.2
C4	0.1μF	ADC common voltage smoothing	See 8.2
R3	75Ω	Coaxial input termination	
C5	0.1μF to 0.01μF	Coaxial input DC cut	Ceramic capacitor
R4	0 to 100Ω	Damping resistor	
R5	100Ω	PLL loop filter	See 8.3
C6	0.068μF	PLL loop filter	See 8.3
C7	0.001μF	PLL loop filter	See 8.3

Figure 15.1 Application Example

# LC89075WA

## Package Dimensions

unit : mm

SPQFP64 10x10 / SQFP64  
CASE 131AK  
ISSUE A

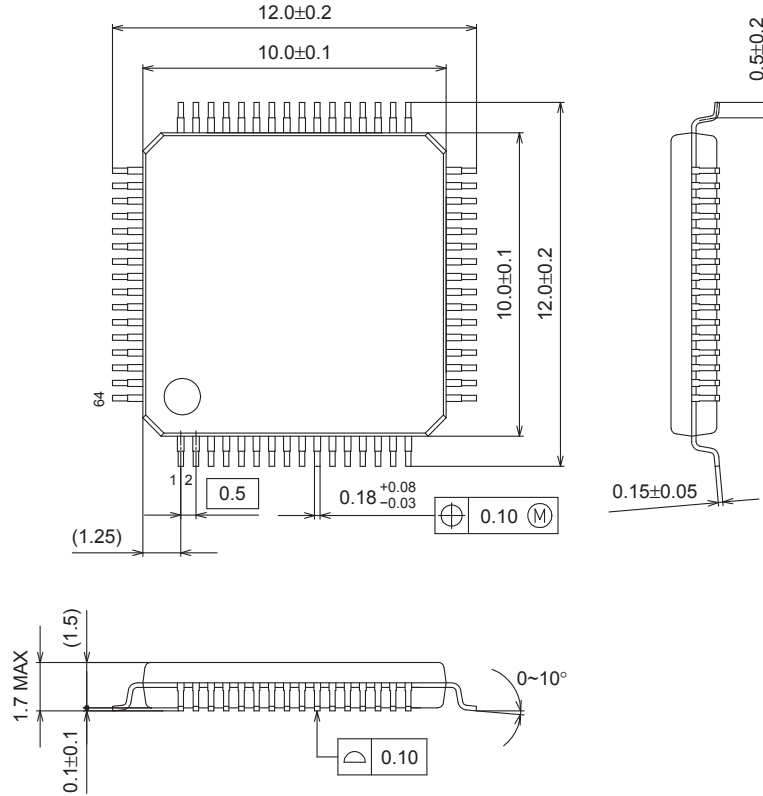

### SOLDERING FOOTPRINT\*

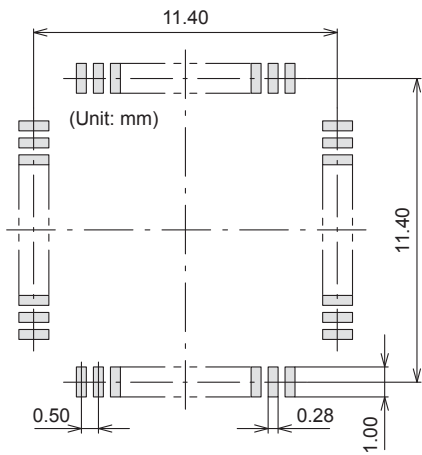

### GENERIC MARKING DIAGRAM\*

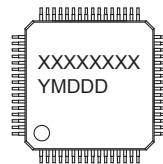
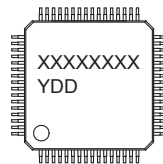

XXXXX = Specific Device Code  
Y = Year  
DD = Additional Traceability Data

XXXXX = Specific Device Code  
Y = Year  
M = Month  
DDD = Additional Traceability Data

\*This information is generic. Please refer to device data sheet for actual part marking. Pb-Free indicator, "G" or microdot "▪", may or may not be present.

NOTE: The measurements are not to guarantee but for reference only.

\*For additional information on our Pb-Free strategy and soldering details, please download the ON Semiconductor Soldering and Mounting Techniques Reference Manual, SOLDERRM/D.

# LC89075WA

## ORDERING INFORMATION

Device	Package	Shipping (Qty / Packing)
LC89075WA-H	SQFP64(10X10) (Pb-Free / Halogen Free)	500 / Tray Foam

ON Semiconductor and the ON logo are registered trademarks of Semiconductor Components Industries, LLC (SCILLC). SCILLC owns the rights to a number of patents, trademarks, copyrights, trade secrets, and other intellectual property. A listing of SCILLC's product/patent coverage may be accessed at [www.onsemi.com/site/pdf/Patent-Marking.pdf](http://www.onsemi.com/site/pdf/Patent-Marking.pdf). SCILLC reserves the right to make changes without further notice to any products herein. SCILLC makes no warranty, representation or guarantee regarding the suitability of its products for any particular purpose, nor does SCILLC assume any liability arising out of the application or use of any product or circuit, and specifically disclaims any and all liability, including without limitation special, consequential or incidental damages. "Typical" parameters which may be provided in SCILLC data sheets and/or specifications can and do vary in different applications and actual performance may vary over time. All operating parameters, including "Typicals" must be validated for each customer application by customer's technical experts. SCILLC does not convey any license under its patent rights nor the rights of others. SCILLC products are not designed, intended, or authorized for use as components in systems intended for surgical implant into the body, or other applications intended to support or sustain life, or for any other application in which the failure of the SCILLC product could create a situation where personal injury or death may occur. Should Buyer purchase or use SCILLC products for any such unintended or unauthorized application, Buyer shall indemnify and hold SCILLC and its officers, employees, subsidiaries, affiliates, and distributors harmless against all claims, costs, damages, and expenses, and reasonable attorney fees arising out of, directly or indirectly, any claim of personal injury or death associated with such unintended or unauthorized use, even if such claim alleges that SCILLC was negligent regarding the design or manufacture of the part. SCILLC is an Equal Opportunity/Affirmative Action Employer. This literature is subject to all applicable copyright laws and is not for resale in any manner.

## Данный компонент на территории Российской Федерации

### Вы можете приобрести в компании MosChip.

Для оперативного оформления запроса Вам необходимо перейти по данной ссылке:

<http://moschip.ru/get-element>

Вы можете разместить у нас заказ для любого Вашего проекта, будь то серийное производство или разработка единичного прибора.

В нашем ассортименте представлены ведущие мировые производители активных и пассивных электронных компонентов.

Нашей специализацией является поставка электронной компонентной базы двойного назначения, продукции таких производителей как XILINX, Intel (ex.ALTERA), Vicor, Microchip, Texas Instruments, Analog Devices, Mini-Circuits, Amphenol, Glenair.

Сотрудничество с глобальными дистрибьюторами электронных компонентов, предоставляет возможность заказывать и получать с международных складов практически любой перечень компонентов в оптимальные для Вас сроки.

На всех этапах разработки и производства наши партнеры могут получить квалифицированную поддержку опытных инженеров.

Система менеджмента качества компании отвечает требованиям в соответствии с ГОСТ Р ИСО 9001, ГОСТ РВ 0015-002 и ЭС РД 009

### Офис по работе с юридическими лицами:

105318, г.Москва, ул.Щербаковская д.3, офис 1107, 1118, ДЦ «Щербаковский»

Телефон: +7 495 668-12-70 (многоканальный)

Факс: +7 495 668-12-70 (доб.304)

E-mail: [info@moschip.ru](mailto:info@moschip.ru)

Skype отдела продаж:

moschip.ru

moschip.ru\_4

moschip.ru\_6

moschip.ru\_9