

Double Layer Capacitors

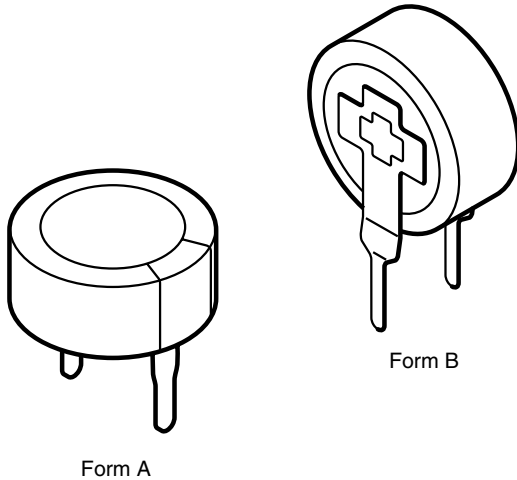


Fig.1 Component outline

FEATURES

- Polarized capacitor with high charge density, alternative product to rechargeable backup batteries
- Dielectric: electric double layer
- Radial leads, cylindrical case, insulated with a blue vinyl sleeve
- Available in both vertical and low-profile versions
- Unlimited charge and discharge cycle numbers
- No charge-discharge control circuitry and no series resistor necessary
- Maintenance-free, no periodic replacement or service necessary
- Ecologically beneficial (no Cd, no Li)
- Lead (Pb)-free versions are RoHS compliant



RoHS
COMPLIANT

APPLICATIONS

- Energy storage, for backup of semiconductor memories (CMOS) in all fields of electronics
- Telecommunication, audio-video, EDP
- General industrial, clock and timer systems

MARKING

The capacitors are marked with the following information:

- Rated capacitance (in F)
- Rated voltage (in V)
- Date code, in accordance with IEC 60062
- Name of manufacturer
- Negative terminal identification
- Upper category temperature (at 85 °C types only)

QUICK REFERENCE DATA				
DESCRIPTION	VALUE			
	STANDARD FORM A	HIGH VOLTAGE FORM A	HIGH TEMPERATURE FORM A	VERTICAL, MINIATURIZED FORM B
Nominal case sizes (Ø D x L in mm)	13 x 7 and 21 x 7.5	13 x 9 and 21 x 9	13 x 9 and 21 x 9	11.5 x 13 (vertical)
Rated capacitance range, C _R	0.047 to 1.0 F	0.047 to 0.68 F	0.047 to 0.68 F	0.047 to 0.33 F
Tolerance on C _R at 20 °C	- 20 to + 80 %			
Rated voltage, U _R	5.5 V	6.3 V	5.5 V	5.5 V
Maximum surge voltage, U _S	6.3 V	7.0 V	6.3 V	6.3 V
Category temperature range	- 25 to + 70 °C	- 25 to + 70 °C	- 25 to + 85 °C	- 25 to + 70 °C
Useful life at U _R :				
at 85 °C	-	-	1000 hours	-
at 70 °C	1000 hours	1000 hours	2800 hours	1000 hours
at 40 °C	8000 hours	8000 hours	23 000 hours	8000 hours
at 25 °C	23 000 hours	23 000 hours	64 000 hours	23 000 hours
Shelf life at 0 V	1000 hours at upper category temperature			
Climatic category IEC 60068	25/070/21	25/070/21	25/085/21	25/070/21

SELECTION CHART FOR C_R, U_R AND FORM AT UPPER CATEGORY TEMPERATURE (UCT)				
C_R (F)	FORM	$U_R = 5.5 V$		$U_R = 6.3 V$
		UCT = 85 °C	UCT = 70 °C	UCT = 70 °C
0.047	A	13 x 9	13 x 7	13 x 9
	B	-	11.5 x 13	-
0.1	A	13 x 9	13 x 7	13 x 9
	B	-	11.5 x 13	-
0.22	A	-	13 x 7	-
	B	-	11.5 x 13	-
0.33	A	-	13 x 7	-
	B	-	11.5 x 13	-
0.47	A	21 x 9	21 x 7.5	21 x 9
	B	-	-	-
0.68	A	21 x 9	-	21 x 9
	B	-	-	-
1.0	A	-	21 x 7.5	-

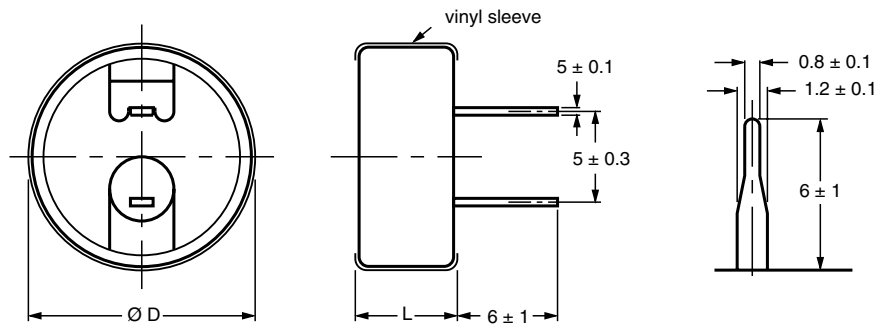
DIMENSIONS in millimeters **AND AVAILABLE FORMS**


Fig.2 Form A: Low profile

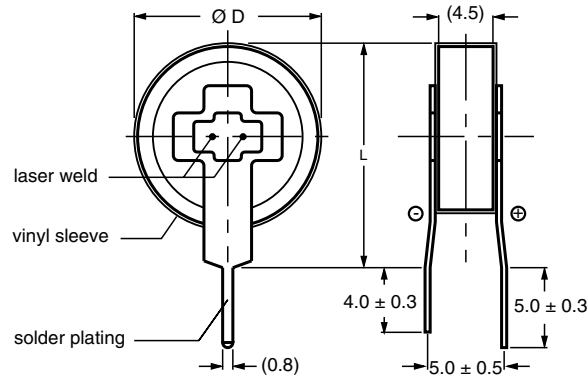


Fig.3 Form B: Vertical

DIMENSIONS in millimeters, MASS AND PACKAGING QUANTITIES						
NOMINAL CASE SIZE $\varnothing D \times L$ (mm)	CASE CODE	FORM	$\varnothing D_{max.}$	$L_{max.}$	MASS (g)	PACKAGING QUANTITIES
11.5 x 13	1	B	11.8	13.5	≈ 1.5	2000
13 x 7	2	A	13.5	7.5	≈ 2.8	1000
13 x 9	3	A	13.5	9.5	≈ 3.4	1000
21 x 7.5	4	A	21.5	8.0	≈ 7.1	500
21 x 9	5	A	21.5	9.5	≈ 8.8	500

Note

Detailed tape dimensions see section 'PACKAGING'



ELECTRICAL DATA	
SYMBOL	DESCRIPTION
C_R	rated capacitance, tolerance - 20/+ 80 %, measured by constant current discharge method
UCT	upper category temperature
I_L	max. leakage current after 30 minutes at U_R
R_I	max. internal resistance at 1 kHz

ORDERING EXAMPLE

Double layer capacitor 196 series

1.0 F/5.5 V

Nominal case size: \varnothing 21 x 7.5 mm; Form A

Ordering code: MAL219612105E3

Former 12 NC: 2222 196 12105

Note

Unless otherwise specified, all electrical values in Table 1 apply at $T_{amb} = 20\text{ }^\circ\text{C}$, $P = 86$ to 106 kPa and $RH = 45$ to 75% .

Table 1

ELECTRICAL DATA AND ORDERING INFORMATION								
U_R (V)	C_R (F)	NOMINAL CASE SIZE \varnothing D x L (mm)	CASE CODE	FORM	UCT ($^\circ\text{C}$)	I_L 30 min. (μA)	R_I 1 kHz (Ω)	ORDERING CODE
Standard series								
5.5	0.047	13 x 7	2	A	70	69	120	MAL219612473E3
	0.1	13 x 7	2	A	70	100	75	MAL219612104E3
	0.22	13 x 7	2	A	70	135	75	MAL219612224E3
	0.33	13 x 7	2	A	70	182	75	MAL219612334E3
	0.47	21 x 7.5	4	A	70	216	30	MAL219612474E3
	1.0	21 x 7.5	4	A	70	315	30	MAL219612105E3
High temperature series								
5.5	0.047	13 x 9	3	A	85	69	300	MAL219622473E3
	0.1	13 x 9	3	A	85	100	200	MAL219622104E3
	0.47	21 x 9	5	A	85	216	50	MAL219622474E3
	0.68	21 x 9	5	A	85	260	50	MAL219622684E3
Vertical, miniaturized series								
5.5	0.047	11.5 x 13	1	B	70	69	120	MAL219632473E3
	0.1	11.5 x 13	1	B	70	100	75	MAL219632104E3
	0.22	11.5 x 13	1	B	70	135	75	MAL219632224E3
	0.33	11.5 x 13	1	B	70	182	75	MAL219632334E3
High voltage series								
6.3	0.047	13 x 9	3	A	70	69	300	MAL219613473E3
	0.1	13 x 9	3	A	70	100	200	MAL219613104E3
	0.47	21 x 9	5	A	70	216	50	MAL219613474E3
	0.68	21 x 9	5	A	70	260	50	MAL219613684E3

MEASURING OF CHARACTERISTICS

CAPACITANCE (C)

Capacitance shall be measured by constant current discharge method.

DISCHARGE CURRENT AS A FUNCTION OF RATED CAPACITANCE								
PARAMETER	VALUE							UNIT
Rated capacitance, C _R	0.047	0.1	0.22	0.33	0.47	0.68	1.0	F
Discharge current, I _D	0.1			1.0				mA

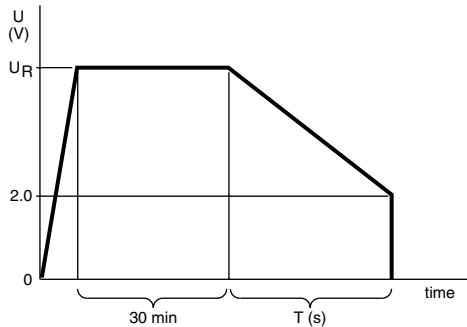


Fig.4 Voltage diagram for capacitance measurement

Capacitance value C_R is given by discharge current I_D, time T and rated voltage U_R, according to the following equation:

$$C(F) = \frac{I_D(mA) \times 10^{-3} \times T(s)}{U_R(V) - 2}$$

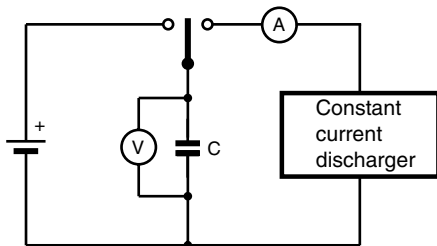


Fig.5 Test circuit for capacitance measurement

INTERNAL RESISTANCE (R_I) AT 1 kHz

$$R_I(\Omega) = \frac{V_C(V)}{10^{-3}}$$

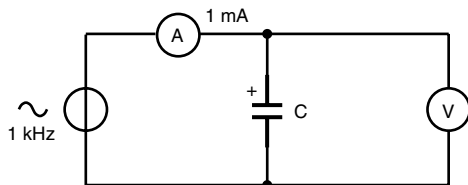


Fig.6 Test circuit for R_I measurement

LEAKAGE CURRENT (I_L)

Leakage current shall be measured after 30 minutes application of rated voltage U_R:

$$I_L(\mu A) = \frac{V(V)}{10^{-4}}$$

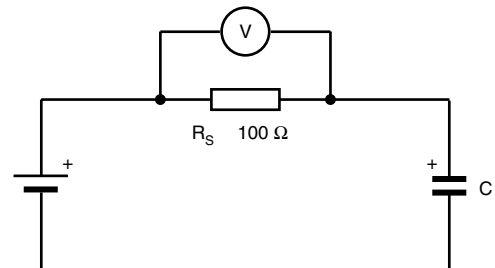


Fig.7 Test circuit for leakage current

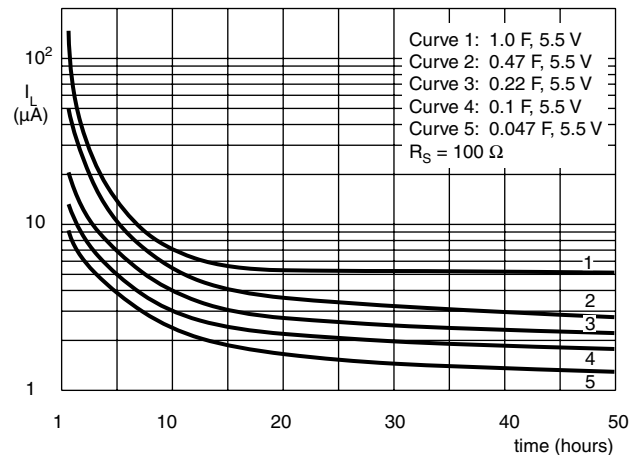


Fig.8 Typical leakage current as a function of time



DISCHARGE CHARACTERISTICS

Backup time of 196 DLC series capacitors depends on minimum memory holding voltage and discharge current (corresponding with the current consumption of the load). For minimum backup times of standard and vertical miniaturized series see Figs 9 and 10 (charging time ≥ 24 hours).

Figure 11 shows the backup time when a 196 DLC capacitor is discharged by a constant resistance (charging time ≥ 24 hours).

The horizontal axis shows the initial value of discharge current if 5 V is connected to the capacitor via a fixed series resistor.

EXAMPLE: 1 μ A CORRESPONDS TO 5 M Ω AND 0.1 μ A CORRESPONDS TO 50 M Ω

The vertical axis shows that period of time during which the voltage drops from 5 to 2 V.

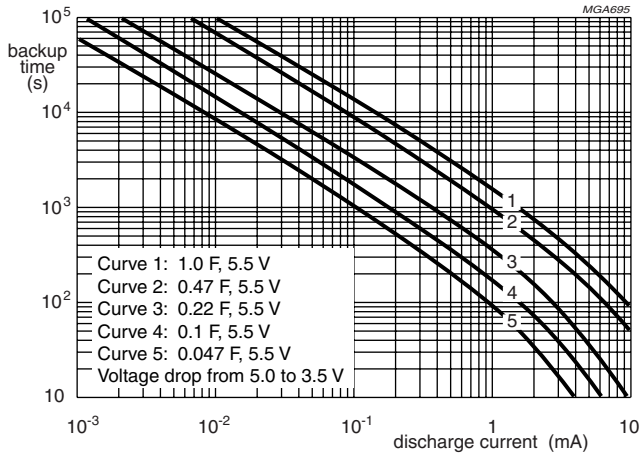


Fig.9 Typical backup time as a function of discharge current

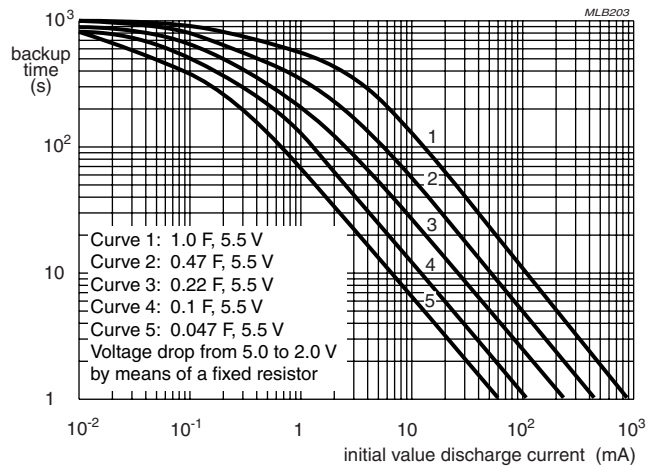


Fig.11 Typical backup time as a function of initial discharge current

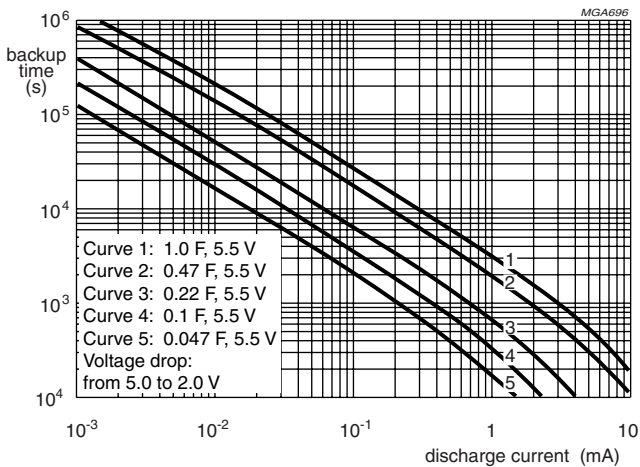


Fig.10 Typical backup time as a function of discharge current

Table 2

TEST PROCEDURES AND REQUIREMENTS for standard and vertical miniaturized series (5.5 V; 70 °C)			
NAME OF TEST	IEC 60384-4/ EN130300 subclause	PROCEDURE (quick reference)	REQUIREMENTS
Robustness of terminations	4.4	tensile strength; application of loading force for 10 seconds: 20 N (standard series) 5 N (vertical miniaturized series)	no breaks
Resistance to soldering heat	4.5	solder bath; 260 °C; 5 seconds	$\Delta C/C: \pm 10 \%$ R_1 and $I_L \leq$ spec. limit
Solderability	4.6	solder bath; 235 °C; 2 seconds	$\geq 75 \%$ tinning
Vibration	4.8	10 to 55 Hz; 1.5 mm; 3 directions; 2 hours per direction	$\Delta C/C: \pm 10 \%$ R_1 and $I_L \leq$ spec. limit
Damp heat, steady state	4.12	500 hours at 55 °C; RH 90 to 95 %; no voltage applied	$\Delta C/C: \pm 30 \%$ $R_1 \leq 4 \times$ spec. limit $I_L \leq 2 \times$ spec. limit
Endurance	4.13	$T_{amb} = 70 \text{ °C}$; 5.5 V applied; 1000 hours	$\Delta C/C: \pm 30 \%$ $R_1 \leq 4 \times$ spec. limit $I_L \leq 2 \times$ spec. limit
Storage at upper category temperature	4.17	$T_{amb} = 70 \text{ °C}$; no voltage applied; 1000 hours	$\Delta C/C: \pm 30 \%$ $R_1 \leq 4 \times$ spec. limit $I_L \leq 2 \times$ spec. limit
Self discharge	-	24 hours storage at room temperature after application of 5 V for 1 hour	remaining voltage: $\geq 4 \text{ V}$
Characteristics at high and low temperature	4.19	step 1: reference measurement at + 20 °C of C, R_1 and I_L step 2: measurement at - 25 °C step 3: measurement at + 20 °C step 4: measurement at + 70 °C step 5: measurement at + 20 °C	$\Delta C/C: \pm 30 \%$ of + 20 °C value $R_1 \leq 5 \times$ the + 20 °C value $I_L \leq 4 \times$ the + 20 °C value



Disclaimer

All product specifications and data are subject to change without notice.

Vishay Intertechnology, Inc., its affiliates, agents, and employees, and all persons acting on its or their behalf (collectively, "Vishay"), disclaim any and all liability for any errors, inaccuracies or incompleteness contained herein or in any other disclosure relating to any product.

Vishay disclaims any and all liability arising out of the use or application of any product described herein or of any information provided herein to the maximum extent permitted by law. The product specifications do not expand or otherwise modify Vishay's terms and conditions of purchase, including but not limited to the warranty expressed therein, which apply to these products.

No license, express or implied, by estoppel or otherwise, to any intellectual property rights is granted by this document or by any conduct of Vishay.

The products shown herein are not designed for use in medical, life-saving, or life-sustaining applications unless otherwise expressly indicated. Customers using or selling Vishay products not expressly indicated for use in such applications do so entirely at their own risk and agree to fully indemnify Vishay for any damages arising or resulting from such use or sale. Please contact authorized Vishay personnel to obtain written terms and conditions regarding products designed for such applications.

Product names and markings noted herein may be trademarks of their respective owners.

Данный компонент на территории Российской Федерации

Вы можете приобрести в компании MosChip.

Для оперативного оформления запроса Вам необходимо перейти по данной ссылке:

<http://moschip.ru/get-element>

Вы можете разместить у нас заказ для любого Вашего проекта, будь то серийное производство или разработка единичного прибора.

В нашем ассортименте представлены ведущие мировые производители активных и пассивных электронных компонентов.

Нашей специализацией является поставка электронной компонентной базы двойного назначения, продукции таких производителей как XILINX, Intel (ex.ALTERA), Vicor, Microchip, Texas Instruments, Analog Devices, Mini-Circuits, Amphenol, Glenair.

Сотрудничество с глобальными дистрибьюторами электронных компонентов, предоставляет возможность заказывать и получать с международных складов практически любой перечень компонентов в оптимальные для Вас сроки.

На всех этапах разработки и производства наши партнеры могут получить квалифицированную поддержку опытных инженеров.

Система менеджмента качества компании отвечает требованиям в соответствии с ГОСТ Р ИСО 9001, ГОСТ РВ 0015-002 и ЭС РД 009

Офис по работе с юридическими лицами:

105318, г.Москва, ул.Щербаковская д.3, офис 1107, 1118, ДЦ «Щербаковский»

Телефон: +7 495 668-12-70 (многоканальный)

Факс: +7 495 668-12-70 (доб.304)

E-mail: info@moschip.ru

Skype отдела продаж:

moschip.ru

moschip.ru_4

moschip.ru_6

moschip.ru_9